

Vanuatu

National Building Code

2025 Edition



Government of the Republic of Vanuatu

Contents

PREFACE

ACKNOWLEDGEMENTS

INTRODUCTION

PART 1 – GENERAL PROVISIONS & STRUCTURE FOR ALL BUILDINGS (CLASS 1 to CLASS 10)

SECTION A - GENERAL PROVISIONS

- A1 Interpreting the VNBC
- A2 Compliance with the VNBC
- A3 Definitions, Referenced Documents & Standards
- A4 Acceptance of Design and Construction
- A5 Classification of Buildings & Structures
- A6 United Buildings
- A7 Building Importance Level
- A8 UXO Survey and Disposal
- A9 Prevention and Control of Asbestos
- A10 Health and Safety at Work
- A11 Universal Design Principles

Specifications

SECTION B - STRUCTURE

Performance Requirements

Deemed-to-Satisfy Provisions

- B1 Structure
- B2 Demolition
- B3 Foundation and Ground Conditions
- B4 Durability

PART 2 – DWELLINGS AND OUTBUILDINGS (CLASS 1 & CLASS 10)

SECTION DC - FIRE RESISTANCE

Performance Requirements

Deemed-to-Satisfy Provisions

- DC1 Fire Resistance and Stability

SECTION DD - ACCESS AND EGRESS

Performance Requirements

Deemed-to-Satisfy Provisions

DD1 Construction of Exits

DD2 Access for people with Disabilities

SECTION DE - ELECTRICITY

Performance Requirements

Deemed-to-Satisfy Provisions

DE1 Electricity Safety

DE2 Amenity

SECTION DF - HEALTH AND AMENITY

Performance Requirements

Deemed-to-Satisfy Provisions

DF1 Damp and Weatherproofing

DF2 Cooking and Sanitary Facilities

DF3 Room Sizes and Heights

DF4 Light and Ventilation

DF5 Water Supply Plumbing

DF6 Sanitary Plumbing and Drainage

DF7 Sanitary Disposal

DF8 Roof Drainage

DF9 Rainwater Storage

Specifications

SECTION DG - ANCILLARY PROVISIONS

Performance Requirements

Deemed-to-Satisfy Provisions

DG1 Minor Structures and Components

DG2 Fireplaces, Chimneys and Flues

PART 3 – PUBLIC BUILDINGS AND GROUP DWELLINGS (CLASS 2 TO 9)

SECTION NC - FIRE RESISTANCE

Performance Requirements

Deemed-to-Satisfy Provisions

NC1 Fire Resistance and Stability

NC2 Compartmentation and Separation

NC3 Protection of Openings
Specifications

SECTION ND - ACCESS AND EGRESS

Performance Requirements

Deemed-to-Satisfy Provisions

- ND1 Provision for Escape
- ND2 Construction of Exits
- ND3 Access for People with Disabilities

SECTION NE - SERVICES AND EQUIPMENT

Performance Requirements

Deemed-to-Satisfy Provisions

- NE1 Fire Fighting Equipment
- NE2 Smoke Control
- NE3 Lift Installations
- NE4 Emergency Lighting, Exit Signs & Warning System
- NE5 Inspection, Test & Maintenance of Safety installations
- NE6 Electrical Work

Specifications

SECTION NF - HEALTH AND AMENITY

Performance Requirements

Deemed-to-Satisfy Provisions

- NF1 Damp and Weatherproofing
- NF2 Sanitary and Other Facilities
- NF3 Room Sizes
- NF4 Light and Ventilation
- NF5 Water Supply Plumbing
- NF6 Sanitary Plumbing and Drainage
- NF7 Sanitary Disposal
- NF8 Roof Drainage

Specifications

SECTION NG - ANCILLARY PROVISIONS

Performance Requirements

Deemed-to-Satisfy Provisions

- NG1 Minor Structures and Components
- NG2 Fireplaces, Chimneys and Flues
- NG3 Atrium Construction

PREFACE

2025 Edition

The National Building Code is empowered by the *Building Act 2013*. This National Building Code establishes the standards for construction work on buildings and facilities as per the Building Act.

- All construction works on building or facilities to which the Building Act applies must comply with the standards for construction of the National Building Code and other regulatory requirements.
- A building permit issued by an *Approval Authority* is required for all construction work on buildings or facilities to which the Building Act applies.
- The *Approval Authority* shall be as per the Building Act. For all Government Buildings and Projects the *Approval Authority* is the Ministry of Infrastructure and Public Utilities.
- Buildings and facilities must be constructed in accordance with the conditions set out in the *building permit* issued by the *Approval Authority* and in compliance with the Building Act, Regulations, and Code and other regulatory requirements.
- A building certificate issued by an approved building certifier must accompany the *building permit application* certifying that the proposed building complies with the Code. The *Approval Authority shall* review the building certificate as part of its consideration of the *building permit* application. Consult the MoIA Director General for the register of building certifiers.

In addition to this Code, you should be aware of other laws, specifications and guidelines administered by the Ministry of Infrastructure and Public Utilities, the Ministry of the Internal Affairs and other agencies. Your attention is drawn in particular to the following:

- Physical Planning & Planning Permission
- Foreshore Development & Permission
- Environmental Protection and Conservation & Permitting
- Land registration & titling
- Fire Safety
- Geology and Mines requirements
- Health and Safety
- Unexploded Ordinance

<https://pwd.gov.vu/>



© Government of the Republic of Vanuatu

ACKNOWLEDGEMENTS

Development of the 'National Building Code – 2025 Edition' was carried out under the auspices of the Vanuatu Government, specifically the Department of Urban Affairs and Planning (DUAP) of the Ministry of Internal Affairs (MoIA) and the Public Works Department (PWD) of Ministry of Infrastructure and Public Utilities (MIPU).

This edition of the National Building Code builds upon the original Code published in 1990 and revised in 2000 and incorporates appropriate advances in practice and knowledge. Accordingly, the Government of Vanuatu acknowledges the excellent work of the many stakeholders (refer pages iv to vii in the 2000 edition) who contributed to the creation of the original 1990 edition and updated 2000 edition.

The Ministry wishes to gratefully acknowledge the stakeholders who contributed to the drafting of this document. They include numerous government ministries and agencies led by the Department of Urban Affairs and Planning (DUAP) and the Public Works Department (PWD), non-government organizations, including organizations representing people with disabilities, development partners, state-owned enterprises, the Vanuatu Engineers Association and private sector building industry professionals.

A thorough, inclusive consultation process was carried out during the second half of 2024 and first half of 2025 including the uploading of the draft VNBC 2025 onto the Ministry of Infrastructure Public Utilities website for 4 weeks and a public request for commentary and submissions.

The Vanuatu Government wishes to express sincere appreciation and thanks to all contributing stakeholders for their participation and valuable contributions.

The Vanuatu Government is grateful to the Pacific Region Infrastructure Facility (PRIF) for supporting this project.

Tankyu tumas



Hon. Andrew Solomon Napuat

Minister for Internal Affairs



Hon. Xavier Emanuel Harry

Minister for Infrastructure and Public Utilities



INTRODUCTION

About this Code

The overall objective of the Code is to ensure that acceptable standards of structural sufficiency, fire safety, health and *amenity*, are maintained for the benefit of the community now and in the future.

The requirements included in this Code are intended to extend no further than is necessary in the public interest, to be cost-effective, not needlessly onerous in their application, and easily understood.

Layout of the Code

The numbering of Sections and Parts has been made on an alpha-numeric system for ease of reference. Ex. Section NF, Part NF1. It provides flexibility to accommodate future additions or deletions, and the future consolidation of building regulations presently contained in other legislation, without undue disruption to the layout. Other than for common provisions contained in Sections A and B, the Code is divided into two areas - one which covers Class 1 and 10 buildings, and the other which covers all other Classes of buildings.

The 2025 code format and numbering remain the same as the original 1990 code and 2000 update. This format and numbering replicate the National Construction Code of Australia and most other Pacific Island National Building Codes. It allows for Construction practitioners from Australia and other Pacific Island Countries to easily interpret the code and for Ni-Vanuatu construction practitioners to easily understand building codes in Australia and other Pacific Island Countries when working or studying outside Vanuatu (which many do). This strategy also supports the harmonization of the construction industry across the Pacific and encourages collaboration between Pacific Island Country construction practitioners.

The National Building Code is divided into **3 Parts**:

PART 1 - GENERAL PROVISIONS AND STRUCTURE FOR ALL BUILDINGS (CLASS 1 TO CLASS 10)

Refer to Sections A and B

PART 2 - DWELLINGS AND OUTBUILDINGS (CLASS 1 & CLASS 10)

Covers Single and Small Dwelling Buildings & Non-habitable outbuildings or structures,

Refer to Sections DC, DD, DE, DF, and DG

PART 3 - PUBLIC BUILDINGS AND GROUP BUILDINGS (CLASS 2 TO CLASS 9)

Covers Public Buildings and Group Dwellings

Refer to Sections NC, ND, NE, NF, and NG

What is in the Code?

The Code sets down the *Performance Requirements* and corresponding *Deemed-to-Satisfy Provisions* which apply to the construction of buildings and facilities for all classes of occupancy.

A building code cannot cover every issue concerned with the design and construction of buildings and facilities. In the case of innovative, complex or unusually hazardous building proposals, or other *building work* or construction work beyond the scope of the Code, legislation may provide for other suitable action.

The Code covers those aspects of buildings that are regulated under the Building Act, such as structure, fire resistance, access and egress, fire-fighting equipment, mechanical ventilation, lift installations, and some aspects of health and *amenity*.

Performance Requirements

These are described in terms which would allow considerable scope for innovation and the development of new materials and methods of construction. The Requirements are in some cases separated into objectives and the required performance.

Objectives are broad statements of intent and are included at the beginning of each Section to identify the objectives that the provisions of the Section are intended to achieve. They are the basic concepts which apply generally to all buildings and structures.

Required Performance identifies the means by which the objectives can be achieved and are expressed in performance terms. Accreditation certificates, test reports, detailed calculations or other documentary evidence may be used as evidence that a particular material, design or construction method meets the *Performance Requirements* of this Code.

Deemed-to-Satisfy Provisions

The *Deemed-to-Satisfy Provisions* have been drafted in sufficiently general terms to allow some flexibility without increasing the need to use administrative discretion. In the absence of national Standards for design, construction and materials, the Standards produced by the Standards Australia and Standards New Zealand have been called up. Detailed specifications have been given where necessary.

The New Zealand Ministry of Foreign Affairs and Trade have made Zealand and joint New Zealand/Australian standards referenced in the Vanuatu National Building Code freely available to Vanuatu regulatory authorities.

Professional Certification

The Code allows for certificates issued by *professional consultants* (*Approved Persons* also known as building certifiers in the Building Act) to be used as evidence of compliance with particular requirements of the Code or standards. A register of building certifiers is maintained as per the requirements of the Building Act.

The enabling legislation will determine the extent of the use of professional certification and the procedures for the submission of certificates, reports, or other documentation to Approval Authorities as evidence of compliance with the Code.

The difference between building codes and building standards

The **Vanuatu National Building Code** sets the minimum requirements for construction and design to protect public safety, health, and welfare.

The **building standards** referenced in the *Deemed-to-Satisfy Provisions* provide detailed technical guidelines to support building codes, including:

- Ensuring consistency, quality, and reliability of materials, products, and practices.
-

-
- Creating a common language in the industry for a given process.
 - Documenting the requirements for products, practices, methods, or operations.

The **Vanuatu National Building Code** is enforced by law, while building standards are legally enforceable only if they are expressly referenced in legislation or legislative instruments such as the Code.

In summary, the key difference between the building code and the building standards referenced in the *deemed-to-satisfy provisions* are:

- **Codes** tell you what needs to be done.
- **Standards** give specifics on how to meet code requirements.
- **Codes** establish minimum standards for construction.
- **Standards** provide expert, detailed procedures for specialized items' construction, materials, manufacture, testing, or installation instructions.
- **Standards** serve as a common language for defining quality and often establish performance and safety criteria

Administrative Arrangements

This Code has been brought into effect by enabling building control legislation which prescribes or "calls up" the technical requirements which have to be satisfied in order to gain *building permit* approval.

The enabling legislation consists of an Act of Parliament and Regulations made under the Act. It empowers the executive government (national, municipal and local) to regulate aspects of the building process and contains the necessary administrative provisions for the work of the *Approval Authority*. The legislation also imposes responsibilities on the authorities and other persons or bodies; and describes particular administrative procedures.

The following administrative matters are covered in the Building Act or *Building Regulations*:

- Plan submission and approval procedures.
- Issue of *building permits*.
- Inspections during and after construction.
- Provision of evidentiary certificates.
- Issue of certificates of occupancy or compliance.
- Accreditation or approval of materials or components.
- Review and enforcement of standards.
- Issue of unfit to occupy notices.
- Fees and charges.

Administrative discretion

The Code is drafted to provide certainty for owners and builders and to minimise the need for the *Approval Authority* to make discretionary decisions. However, in many cases it is not possible to draft a provision in purely technical terms, and an informed judgement is required on the standard which would be suitable in particular circumstances.

Accordingly, in a number of clauses, the Code requires a particular material or construction method to be "suitable", meaning fit in all relevant respects for its intended purpose and use.

The *Approval Authority* responsible for the enforcement of building controls has the right to question "suitability" When the proposed construction proposes a solution different to that of the *Deemed-to-Satisfy Solutions* of the Building Code, The *Approval Authority* shall seek the approval of MIPU / Public Works Department for the use of a new method of construction, design, or materials. See Building Act. Differences of opinion are open to appeal.

.

PART

1



GENERAL PROVISIONS & STRUCTURE FOR ALL BUILDINGS (CLASS 1 TO CLASS 10)

Section

A

(a)



GENERAL PROVISIONS

THIS SECTION APPLIES TO ALL BUILDINGS
(CLASS 1 TO CLASS 10)

Contents

A1	Interpreting the VNBC	1
A1.1	Part 1: General Provisions and Structure for All Buildings	1
A1.2	Part 2: Class 1 and Class 10	1
A1.3	Part 3: Class 2 to Class 9	1
A1.4	Minor Repairs and Structures within VNBC Scope	1
A1.5	Safety and Protection of Users and the Public	2
A1.6	Interpretation	2
A2	Compliance with the VNBC	2
A2.1	National Compliance	2
A2.2	Compliance	2
A2.3	Deemed-to-Satisfy Solution	3
A2.4	Performance Solution	3
A2.5	A Combination of Solutions	3
A3	Definitions, Referenced Documents & Standards	3
A3.1	Definitions	3
A3.2	Referenced Documents	13
A3.3	Referenced Standards, Etc	14
A3.4	Differences Between Referenced Documents and this Code	14
A3.5	Mandatory Provisions	14
A3.6	Adoption of Referenced Documents	14
A4	Acceptance of Design and Construction	14
A4.1	Suitability	14
A4.2	Evidence of Suitability	15
A4.3	Fire Hazard Properties	15
A4.4	Material Durability	15
A4.5	Use of Locally Grown Timber	16
A4.6	Documentation	16
A5	Classification of Buildings & Structures	16
A5.1	Principles of Classification	16
A5.2	Building Classifications	16
Class 1	Buildings	17
Class 2	Buildings	17

SECTION A -GENERAL PROVISIONS

Class 3 Buildings	17
Class 4 Part of a building	17
Class 5 Buildings	17
Class 6 Buildings	17
Class 7 Buildings	18
Class 8 Buildings	18
Class 9 Buildings	18
Class 10 Buildings.....	18
Mixed use buildings.....	19
A5.3 Multiple Building Classifications	19
A6 United Buildings	19
A6.1 United Buildings	19
A6.2 Alterations in a United Building.....	19
A7 Building Importance Level	20
A7.1 Building Importance Level.....	20
A7.2 Building Design Life.....	23
A8 UXO Survey and Disposal	23
A8.1 UXO Definitions	23
A8.2 UXO Risk Assessment, Survey Type, and Clearance	23
A9 Prevention and Control of Asbestos	24
A9.1 Asbestos Definitions	24
A9.2 Prohibition on the Importation, Re-use, Fabrication and recycling of Asbestos and Asbestos Containing Materials in Buildings	24
A9.3 Removal and Disposal of Asbestos or Asbestos Containing Materials	24
A10 Health and Safety at Work	24

SPECIFICATIONS

SPECIFICATION A3.3.1: STANDARDS ADOPTED BY REFERENCE

SPECIFICATION A4.3.1: FIRE-RESISTANCE OF BUILDING ELEMENTS

SPECIFICATION A4.3.2: EARLY FIRE HAZARD TEST FOR ASSEMBLIES

A1 Interpreting the VNBC

This Part explains how the Vanuatu National Building Code (VNBC), i.e., the Code, must be interpreted and applied; the scope of each VNBC Part; and how specific terms are used to understand the technical and legal requirements of the VNBC.

A1.1 Part 1: General Provisions and Structure for All Buildings

The VNBC Part 1 (excluding specifications A4.3.1 and A4.3.2) contains the general provisions and mandatory requirements for all construction work on *buildings* and facilities.

1. The VNBC applies to construction work on *buildings* and facilities in accordance with the Act.
2. The VNBC does not apply to existing *buildings* and structures unless the following is applicable:
 - a. Existing Class 2 to Class 9 *buildings* and structures that are designated as Importance Level 4 shall be assessed and upgraded to the degree necessary to comply with all *Performance Requirements* of this Code by the year 2040 with consideration of their remaining *design life*.
 - b. Existing Class 2 and Class 9 *buildings* and structures shall comply with all *Performance Requirements* of this Code, when one or more of the following occurs:
 - i. Change in Building Class.
 - ii. Change in Importance Level.
 - iii. *Significant alteration* of the structure (refer A4.1 Definitions to determine what a *significant alteration* comprises).
 - c. Existing *buildings* and structures that are damaged, considered potentially dangerous, or considered potentially hazard prone as per Section B. The VNBC shall be used as the basis for assessment, mitigation, and/or demolition.

A1.2 Part 2: Class 1 and Class 10

The VNBC Part 2 contains the requirements for

- (a) All *buildings* in Building Class 1 and Class 10a; and
- (b) Certain structures in Building Class 10b.

A1.3 Part 3: Class 2 to Class 9

The VNBC Part 3 contains the requirements for

- (a) All Building Class 2 to Class 9; and
- (b) Certain structures in Building Class 10b.

A1.4 Minor Repairs and Structures within VNBC Scope

Minor *building* repairs and construction not covered by this National Building Code include the following:

1. Minor repairs as defined under A4.1 – Definitions;
2. Horizontal infrastructure, including sea walls, bridges, wharves, jetties and pipework infrastructure. Guidance on the design of these types of structure are covered by other Ministry of Infrastructure and Public Utilities Standards, Specifications and Guidelines and other Government of Vanuatu ministries and jurisdictions;
3. Stand-alone plant and machinery systems and their supporting structures if they are bespoke and supplied with the machinery or plant; and
4. A mast, pole, or radio or television aerial that does not exceed 6 meters in height.

The *Approval Authority* and Ministry of Infrastructure and Public utilities shall be consulted to determine the most suitable standard for construction of *buildings* and facilities not covered by this Code prior to issuing of a *building permit* and/or commencing construction.

A1.5 Safety and Protection of Users and the Public

Regardless of whether a *building* or structure is within the Scope of the National Building Code, under clause A1.1 or A1.4, all *buildings* and facilities constructed in Vanuatu shall adhere to the performance requirements and principles of the National Building Code – namely that they be designed, constructed, maintained, altered, repaired, and/or demolished in such a manner as to ensure the safety, health, and protection of users and the public and prevent injury and death.

A1.6 Interpretation

- (1) The following components of the VNBC are mandatory for all *buildings* and structures:
 - a. Section A; and
 - b. Performance requirements stated at the beginning of all other Sections.
- (2) The following components of the VNBC are non-mandatory and informative elements:
 - a. “Preface” information;
 - b. “Acknowledgments” information; and
 - c. “Introduction” information.
- (3) Terms in italics must be interpreted in accordance with definitions provided in A3.1, unless otherwise noted, and any additional definitions in national and local laws.
- (4) To “the degree necessary” means that consideration of all criteria in the Performance Requirement will determine the outcome appropriate to the circumstances; and that in certain cases it may not be necessary to incorporate specific measures.
- (5) Figures are for illustrative purposes and should not be interpreted as containing all required design information.

A2 Compliance with the VNBC

This Part explains the various compliance pathways within the VNBC and the appropriate steps that must be taken to demonstrate compliance with the VNBC.

A2.1 National Compliance

Compliance with the VNBC is required for all *buildings* and structures in the Republic of Vanuatu.

Other national legislation and regulations that are more stringent than the VNBC shall be used provided that all Performance Requirements (Objectives and Required Performance) listed in the VNBC are complied with or exceeded.

A2.2 Compliance

Compliance with the VNBC is achieved by complying with the General Provisions of the VNBC and the Performance Requirements.

Performance Requirements are satisfied through a Performance Solution, a *Deemed-to-Satisfy Solution*, or a combination of both.

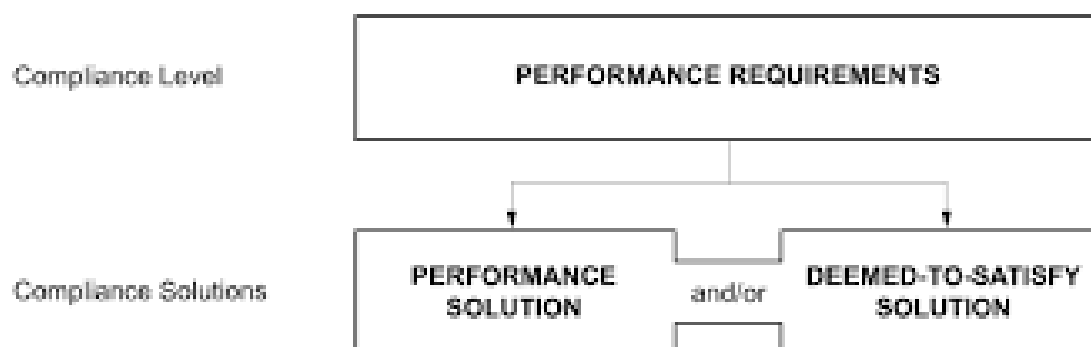

A2.3 Deemed-to-Satisfy Solution

A *Deemed-to-Satisfy Solution* that complies with the *Deemed-to-Satisfy Provisions* is deemed to have met the *Performance Requirements*.

Deemed-to-Satisfy Assessment Methods to demonstrate compliance of the *Deemed-to-Satisfy Solution* with the *Deemed-to-Satisfy Provision* include one or more of the following:

- Evidence of Suitability in accordance with Part A4.
- Expert Judgment.
- Where locally produced materials are used, such as locally grown timber, locally manufactured block work, sand and aggregate, the building product shall have a building product certificate obtained through the procedures outlined in the Building Act and Regulations that demonstrates compliance with this Code.

A2.4 Performance Solution

- (1) A *Performance Solution* must demonstrate compliance with all relevant *Performance Requirements*; OR the solution must be at least equivalent to the *Deemed-to-Satisfy Provisions*.
- (2) *Performance Solution* Assessment Methods to demonstrate compliance with the relevant *Performance Requirements* include one or a combination of the following:
 - a. Comparison with the Deemed-to-Satisfy Provisions;
 - b. Evidence of Suitability in accordance with Part A4;
 - c. Expert judgment;
 - d. Verification methods provided in the VNBC; and
 - e. Verification methods, accepted by the authority.
- (3) A *Performance Solution* must clearly identify which *Performance Requirement(s)* the solution demonstrates compliance with AND if there are any other *Performance Requirement(s)* that are relevant or are affected by the *Performance Solution*.
- (4) When a *Performance Solution* is proposed, the following steps must be taken:
 - a. prepare a performance-based design brief in consultation with stakeholders; and
 - b. prepare a report that presents the assessment methods, acceptance criteria, analysis, results, details of conditions or limitations, and confirmation that *Performance Requirement* has been met.

Where locally produced materials, such as locally grown timber, locally manufactured block work, and locally extracted sand and aggregate do not have a building product certification as per the Building Act, the *Performance Solution* assessment methods shall be used to demonstrate compliance with the relevant *Performance Requirements*. The *Performance Solution* shall be reviewed for suitability by the Director of Public Works in accordance with the procedures in the Building Act and Regulations that demonstrates compliance with this Code.

A2.5 A Combination of Solutions

Compliance with *Performance Requirements* can be achieved using a combination of *Deemed-to-Satisfy Solutions* and *Performance Solutions* in accordance with the assessment methods listed in Parts A2.3 and A2.4.

A3 Definitions, Referenced Documents & Standards

A3.1 Definitions

Some of the words and phrases used in the Code have specific defined meanings. Wherever such meaning is intended the words and phrases are printed in italics. The defined meanings are:

Accessible – having features to enable use by people with disabilities.

Accessible Route – An *accessible* route is a continuous, unobstructed path that connects all *accessible* elements and spaces within a *building* or facility. It must be usable by people with disabilities, including those using wheelchairs or other mobility aids. This route typically includes corridors, ramps,

SECTION A -GENERAL PROVISIONS

elevators, doorways, and walkways, and must meet specific width, gradient, and surface requirements to ensure safe and independent access.

Accessway – a continuous *accessible* path of travel to, into or within a *building*.

Alteration – in relation to a *building*, includes an addition or extension to a *building*.

Amenity – an attribute which contributes to the health, physical independence, comfort and well-being of people.

Approval Authority – A local government council, or municipal council, or person appointed by the Minister of Internal Affairs under the Building Act. The *Approval Authority* for Government *buildings* and projects is the Ministry of Infrastructure and Public Utilities.

Approved Person(s) – Building certifier(s) that certifies that the proposed *building*, or specific aspects, complies with the Code and the Building Act and *Building Regulations* by providing a signed and completed *Compliance Certificate*. A building certifier is an engineer, technician, or architect that is appointed under the Building Act and Regulations that must have the prescribed qualifications and experience, be in good standing, and be listed on the register of appointed building certifiers. The regulations may limit the scope of *approved persons* (building certifiers) to specific building classes, importance levels, disciplines, height, size, or other requirement.

Appropriately Qualified Person – A person recognized by the *Approval Authority* as having qualifications and/or experience in the relevant discipline in question; that serves to provide evidence of suitability of materials, products, form of construction, and/or design.

Assembly building – a *building* where people may assemble for:

- (a) civic, theatrical, social, political or religious purposes;
- (b) educational purposes in a school, early childhood center, preschool, or the like;
- (c) entertainment, recreational or sporting purposes; or
- (d) transit purposes.

Atrium – a space within a *building* that connects 2 or more *storeys*, and:

- (a) Is wholly or substantially enclosed at the top by a floor or roof (including a glazed roof structure); and
- (b) Includes any adjacent part of the *building* not separated by bounding construction; but
- (c) Does not include a stairwell, ramp-well or the space within a *shaft*.

Automatic(ally) – applied to a fire door, smoke door, fire shutter, smoke-and-heat vent, alarm system or the like, means designed to operate when activated by a heat, smoke- or fire-sensing device.

Baluster – a vertical support for a handrail.

Building – a structure designed for use by people, animals, machinery or chattels, whether the structure is temporary, permanent, moveable or immovable, and includes:

- (a) Any services or systems attached to and forming part of the structure.
- (b) Any construction in, on or over the foreshore as defined by the Foreshore Development Act.

Building Element – primary structural frame members, load-bearing walls, common and interior walls, fire walls, floor and/or roof construction including secondary members, exit construction, foundations, and windows.

Building Permit – a document issued by the *Approval Authority* under the Building Act and Regulations allowing the construction, *alteration* or demolition of a *building*, facility, siteworks, site servicing and/or site to proceed according to conditions of the *building permit*.

Building Regulations – a legally binding set of requirements issued under the Building Act setting out details of the development process including procedures, exemptions, fees and charges and infringement penalties.

Building Work – the construction of a *building*, including all excavations for foundations, structural work, electrical work, sanitary installations and plumbing.

SECTION A -GENERAL PROVISIONS

Certificate of Accreditation – a certificate acceptable to the *Approval Authority* stating that the properties and performance of a building material or method of construction or design fulfil specific requirements of this Code; in accordance with the Building Act and *Building Regulations*.

Certificate of Compliance – a certificate issued and signed by a building certifier (*Approved Person*) acceptable to the *Approval Authority* stating that the materials, methodology of construction and workmanship of a completed *building*, *building element* or design fulfil specific requirements of this Code; in accordance with the Building Act and *Building Regulations*.

Charged Dry Riser Main System – one or more *riser mains* in a *building* complete with all *required* fittings, not permanently connected to a *fire main*. Instead of leaving the system dry, it is charged with water from any convenient domestic supply in order to make it self-monitoring against inadvertently left open *hydrant* valves and leakage.

Cladding – exterior surface of a *building* attached to external walls, the roof, or any other exterior surface.

Combustible –

(a) applied to a material – means *combustible* under AS 1530.1.

(b) applied to construction or part of a *building* – means constructed wholly or in part of *combustible* materials.

(See definition of *non-combustible*)

Common Wall – a wall that is common to adjoining *buildings*.

Curtain Wall – a *non-loadbearing external wall* that is not a *panel wall*.

Damp-Proof Course (DPC) – a continuous layer of impervious material placed in a masonry wall or pier, or between a wall or pier and a floor, to prevent the upward or downward migration of water.

Dead Load – the weight assigned to the *building elements* of a *building storey* excluding people or goods.

Deck – an open platform projecting from an external wall of a *building* and supported by framing and may be open underneath or partially or fully enclosed.

Deemed-to-Satisfy Provision – a provision that is deemed to satisfy the *Performance Requirements*.

Deemed-to-Satisfy Solution – a method of satisfying the *Deemed-to-Satisfy Provisions*.

Design Flood Level (DFL) – hypothetical estimation of the height (elevation) above ground level that would be inundated by *flooding* as a result of storm surge, tsunami, or rainfall, as determined by an *Approval Authority* and/or the Government of Vanuatu. Includes climate change induced sea level rise and rainfall.

Design Life – the duration of a *building*, facility, or site from construction to demolition; or equipment from installation to removal

Design Scenario – the specific scenario of which the sequence of events is quantified, and a fire safety engineering analysis is conducted against.

Design Wind Speed – the design gust wind speed for the area where the *building* is located, calculated in accordance with AS/NZS 1170.2.

Desludge/Desludging – removal of accumulated sludge and scum from the septic.

Drain – a line of pipes to carry *sewage* or *trade waste*, located within the property boundary, laid above or below ground, and includes all fittings and equipment such as inspection openings, traps and gullies.

(a) It is a branch *drain* if it is intended to receive the discharge from fixture discharge pipes.

Branch *drains* join a main *drain*.

(b) The main *drain* collects the *wastewater* from branch *drains* and/or from fixture discharge pipes and conveys them to the *sewer*.

Drainage Ditch – an open channel lower in elevation than the surrounding land intended to collect and convey stormwater on private or public property.

SECTION A -GENERAL PROVISIONS

Durability – the safe performance of a *building*, facility or site for the designed life expectancy assuming the design and a regular schedule of maintenance activities is conducive with site conditions, and that does not result in unforeseen cost for maintenance and repair.

Early Childhood Center – a preschool, kindergarten or child-minding center.

Effective Height – the height to the floor of the topmost *storey* (excluding the topmost *storey* if it contains only heating, ventilating, lift or other equipment, water tanks or similar service units) from the floor or open *space*. The road or open *space* must be capable of providing unobstructed access to emergency vehicles.

The *effective height* of a stepped or terraced *building* is the maximum *effective height* of any segment of the *building*.

Exit –

(a) Any one or a combination of the following, if they provide egress to a road or *open space*:

1. an internal or external stairway;
2. a ramp complying with Section ND;
3. a fire-isolated passageway; or
4. a doorway opening to a road or *open space*.

(b) A horizontal exit or a fire-isolated passageway leading to a *horizontal exit*.

External Wall – an outer wall of a *building* which is not a *common wall*.

Fire Brigade Booster Connection – a connecting device enabling the fire brigade to pressurize or pump water into a *riser main* or other systems.

Fire Compartment – a part of a *building* which is separated from the remainder in accordance with this Code to resist the spread of fire and smoke.

Fire-isolated Passageway – a corridor, hallway or the like, of *fire-resisting* construction, which provides egress to or from a *fire-isolated stairway* or *fire-isolated ramp* to a road or *open space*.

Fire-isolated Ramp – a ramp within a *fire-resisting* enclosure which provides egress from a *storey*.

Fire-isolated Stairway – a stairway within a *fire-resisting shaft* and includes the floor and roof or top enclosing structure.

Fire Main – a water supply service pipe located outside a *building* to supply water at adequate pressures and rates of flow for firefighting purposes. The *fire main* must be:

- (a) Part of a public supply system kept permanently charged with water; or
- (b) Privately provided in which case it must either be permanently charge with water from a reliable supply or be provided with adequate *on-site* storage and fire pumps.

Fire-protective Covering – inert material applied in such a manner that it protects other materials or *building elements* from the damaging effects of fire. Acceptable materials are:

- (a) 13 mm fire-protective grade plasterboard;
- (b) 12 mm cellulose fibre reinforced sheeting;
- (c) 12 mm mesh-reinforced fibrous plaster in which the mesh is 13 mm x 13 mm x 0.7 mm welded wire located not more than 6 mm from the exposed face; or
- (d) Other material not less fire-protective than 13 mm fire-protective grade plasterboard, fixed in accordance with the normal trade practice for a *fire-protective covering*.

Fire-resistance Level (FRL) – the grading periods in minutes determined in accordance with Specification A5.3, for:

- (a) Structural adequacy;
- (b) Integrity; and
- (c) Insulation,

and expressed in that order.

SECTION A -GENERAL PROVISIONS

Fire-resisting – applied to a *structural member* or other part of a *building*, means having the FRL *required* for that *structural member* or other part.

Fire-resisting Construction – one of the types of construction referred to in Part NC1.

Fire-separated Section – a part of a *building* which is separated from the remainder by *fire walls* in accordance with Part NC2 and thereby regarded as a separate *building*.

Fire-source Feature –

- (a) The far boundary of a road adjoining the allotment;
- (b) A side or rear boundary of the allotment; or
- (c) An *external wall* of another *building* on the allotment which is not of Class 10.

Fire Wall – a wall that divides a *storey* or *building* to resist the spread of fire and smoke and has the FRL *required* under Specification NC1.1.

Fixture Unit – a unit of measure based on the rate of discharge, time of operation and frequency and use of a sanitary fixture, that denotes the hydraulic load contributed by that fixture to the sanitary plumbing system.

Flammability Index – the index number determined under AS 1530.2.

Flight – the part of a stair that has a continuous series of risers not interrupted by a landing or floor.

Flood – an inundation of water on the ground surface above normal levels.

Flood hazard area – the site (whether or not mapped) encompassing land lower than the *flood hazard level* (FHL) which has been determined by the *Approval Authority*.

Flood hazard level (FHL) – The flood level used to determine the height of floors in a building (or the underside of structural element if the structure is open below) and represents the DFL (at the DFE) plus freeboard plus sea level rise for the *design life*.

Flooding – a rise or overflow of water onto lands not normally submerged typically resulting from a result of heavy rainfall, storm surge, raised groundwater levels, overflow of river channels, increases in runoff from land or blocked drainage systems, among others.

Floodplain – areas adjacent to rivers and coasts which flood during periods of heavy rain from storm surge.

Floor Area –

- (a) In relation to a *building*: the total area of all *storeys*; and
- (b) In relation to a *storey*: the area of all floors of that *storey* measured over the enclosing walls (if any) and that part of any *common wall* located within the allotment; and
- (c) In relation to a *room*: the area of the *room* measured within the finished surfaces of the walls, and includes the area occupied by any cupboard or other built-in furniture, fixture or fitting.

Floor Drain – a plumbing fixture installed on the floor of a *building* that accepts and conveys water piping connected to a suitable discharge area.

Foundation – the ground which supports the *building*.

Framing – timber or metal members to which lining, wallboard, insulation, *cladding*, flooring or decking is attached, or which support the structure or resist forces applied to it.

Fuel Supply – pipes and associated fittings that contain pressurized flammable mixtures of hydrocarbon gases to supply energy for heating and cooling in a *building* facility, including Liquefied Petroleum Gas (propane) and natural gas (methane).

Glazing – a transparent or translucent element and its supporting frame located in the envelope and includes a window other than a roof light.

Going – the horizontal dimension from the front to the back of a tread less any overhang from the next tread or landing above

Habitable Room – a room used for normal domestic activities, and:

SECTION A -GENERAL PROVISIONS

(a) Includes a bedroom, living room, lounge room, music room, television room, kitchen, dining room, sewing room, study, playroom, family room and sunroom; but

(a) Excludes a bathroom, laundry, water closet, pantry, walk-in wardrobe, corridor, hallway, lobby, photographic darkroom, clothes-drying room, and other spaces of a specialized nature occupied neither frequently nor for extended periods.

Handrail – a rail to provide support to or assist with the movement of a person.

Hazard – anything with an unreasonable risk of bodily injury or deterioration of health or causes a disaster

Healthcare Building – a nursing home, hospital, convalescent home, infirmary or similar institution or home for sick or disabled persons needing full-time nursing care; or a clinic or day surgery unit where:

(a) Prescribed surgical procedures are performed on people who do not require overnight care as in-patients in a hospital; and

(b) The surgical procedures include a potential requirement for general anaesthesia, major regional anaesthesia or intravenous sedation.

Horizontal Exit – a *required* doorway through a *required fire wall* separating two portions of a *building* with approximately the same floor level so as to establish an area of refuge affording safety from fire and/or smoke in the portion from which the escape is made.

Hydrant – a fire service outlet fitting installed in a *riser main* or a *fire main* which provides a valved outlet to permit a controlled supply of water to be taken from the main for firefighting. *Hydrants* installed in a *riser main* system within a *building* are referred to as internal *hydrants* and those installed in a *fire main* outside a *building*, as external *hydrants*.

Inspector – Building Inspector (under Building Act) or Environmental Health inspector of a Municipality or Provincial Government.

Insulation – in relation to an FRL, means the ability to maintain a temperature on the surface not exposed to the furnace below the limits specified in AS 1530.4.

Integrity – in relation to an FRL, means the ability to resist the passage of flames and hot gases specified in AS 1530.4.

Internal Wall – excludes a *common wall* or a party wall.

Junction – a sanitary fitting used to connect one or more branch pipes or channels to a main pipe or channel.

(a) A square *junction* connects the main pipe at right angles and has an airtight removable cap to facilitate inspection and cleaning.

(b) An inspection branch is a *junction* with an airtight removable cap to facilitate inspection and cleaning.

Landing – an area at the top or bottom of a *flight* or between two *flights*.

Lightweight Construction – see Specification NC1.4.

Live Load – the weight of everything temporarily adding load to a structure, such as people or goods in/on a *building storey* but not including anything permanently attached to it.

Loadbearing – intended to resist force and moments additional to those due to its own weight.

Marine and River Protection Zone – Zone located within 50 m of marine or river environment.

Mezzanine Floor – an intermediate floor within a room which is not more than 1/3 of the floor area of the room or 200 m², whichever is the lesser.

Minor repair – a repair that is a like for like replacement of deteriorated elements of a *building* or the replacement of *cladding* or non-structural elements following localized damage. Upgrading the structural capacity of existing connections between structural elements without changes to the members is also considered a minor repair.

A repair is not a *minor repair* if it:

(a) Affects the structural adequacy of the *building* including underpinning of foundations; or

SECTION A -GENERAL PROVISIONS

- (b) Is a conversion of a non-habitable space into a habitable space, such as a ceiling space, underfloor space, or a garage, into a habitable room (as defined by the VNBC); or
- (c) Requires specialist design input from a practitioner in an area such as foundations or geotechnical design, engineering, energy efficiency, *building* services or fire safety; or
- (d) Affects the requirements necessary to avoid the spread of fire to or from any adjoining *building*; or
- (d) Is over any third-party services or easements; or
- (e) Impacts on the protection of any adjoining property; or
- (f) Will adversely affect the safety, health or *amenity* of people using the *building*; or
- (g) Negatively impacts on the functioning of any existing Code-required *building elements*; or
- (h) Would trigger a change in the *building's* occupancy permit; or
- (i) Involves a change of use or a change in the classification of the existing *building* or of the part being repaired; or,
- (j) Includes repair works to greater than 50% of the gross floor area.

Mixed Traditional-Commercial Building Material – These are *buildings* constructed from a mixture of traditional materials and commercially manufactured materials. These *buildings* may use commercially manufactured materials for key construction elements such as the building frame and roof and are then in-filled using traditional materials.

Non-combustible –

- (a) Applied to a material – means not *combustible* except that the material may have a *combustible* surface finish if the finish is not more than 1 mm thick and the *Spread-of-Flame Index* of the assemblage is 0; and
- (b) Applied to construction or part of a *building* – means constructed of *non-combustible* material on all exposed faces.

The following materials, though *combustible* or containing *combustible* materials, are required:

- (a) Plasterboard;
- (b) Perforated gypsum lath with a normal paper finish;
- (c) Fibrous plaster sheet conforming to AS 2185;
- (d) Cellulose fiber cement sheeting; and
- (e) Any other material not less fire-protective than any of the materials from above.

Open-deck Carpark – a carpark in which all parts of the parking *storeys* are cross-ventilated by permanent unobstructed openings in not fewer than 2 opposite or approximately opposite sides, and:

- (a) Where each side that provides ventilation is not less than 1/6 of the area of any other side; and
- (b) The openings are not less than ½ of the wall area of the side concerned.

Open Garage – a carport or garage with 2 or more sides substantially open.

Open Space – a space on an allotment, or a roof or similar part of a *building* complying with ND2.12, open to the sky and connected directly with a public road.

Open Spectator Stand – a tiered stand substantially open at the front.

Panel wall – a *non-loadbearing external wall*, in frame or similar construction, that is wholly supported at each *storey*.

Performance Requirement – a requirement which states the level of performance which a *Performance Solution* or *Deemed-to-Satisfy Solution* must meet.

Performance Solution – a method of complying with the *Performance Requirements* other than by a *Deemed-to-Satisfy Solution*. A building solution in accordance with the Building Act.

Piping Junction – a sanitary fitting used to connect one or more branch pipes or channels to a main pipe or channel

SECTION A -GENERAL PROVISIONS

Pitch – the maximum angle to the horizontal of a line connecting the nosings of stair treads in a single straight flight of a stairway.

Plumbing – the system of pipes, tanks, fittings, and other apparatuses required for potable water supply, wastewater removal and/or treatment, and ventilation / heating or cooling in a *building*, facility or site.

Private Garage –

- (a) Any garage of a Class 1 *building*; or
- (b) Any single *storey* of a *building* of another Class capable of accommodating not more than 3 vehicles, if there is only one such *storey* in the *building*.

Professional Consultant – a person with appropriate experience, qualifications, and specialization in the relevant field, being:

- (a) An *Approved Person* practicing in Vanuatu; or
- (b) Registered on the National Engineering Register (NER) of the Institution of Engineers Australia and is an *Approved Person*; or
- (c) Registered under the Registration Authority for Chartered Professional Engineer, New Zealand and is an *Approved Person*; or
- (d) Registered as a Professional Engineer in the United States and is an *Approved Person*.

Public Carpark – a *building* that is used for the parking of motor vehicles but is neither a *private garage* nor used for the servicing of vehicles, other than washing, cleaning or polishing.

Public Corridor – an enclosed corridor, hallway, or the like which:

- (a) Serves as a means of egress from 2 or more *sole-occupancy units* to a *required exit* from the *storey* concerned; or
- (b) Is *required* to be provided as a means of egress from any portion of a *storey* to a *required exit*.

Registered Testing Authority –

- (a) An organization accredited by the Australian National Association of Testing Authorities (NATA) Silverwater NSW AUSTRALIA to test in the relevant field; or
- (b) an organization accredited by the International Accreditation New Zealand (IANZ) Auckland, NEW ZEALAND to test in the relevant field; or
- (c) An organization recognized by NATA or IANZ through a mutual recognition agreement.
- (d) Alternative testing authorities may be proposed for approval if *required*. Supporting documentation for any alternative testing authority must be submitted. This must demonstrate capability, testing methodology and accreditation as necessary. See Building Act.

Repairs – action taken to restore the structural strength or appearance of a *building* without making any addition or extension to it.

Required – by this Code.

Resistance to the incipient spread of Fire – in relation to a ceiling membrane, means the ability of a ceiling membrane to insulate the space between the ceiling and roof, or ceiling and floor above, to limit the temperature rise of *combustibles* in this space during the Standard *Fire Test* to 180°C.

Rise – in *storeys*: the greatest number of *storeys* calculated in accordance with NC1.2 at any part of the *external walls* of the *building* –

- (a) above the finished ground next to that part; or
- (b) if part of the *external wall* is on the boundary of the allotment, above the natural ground level at the relevant part of the boundary.

Riser (not to be confused with “Riser” as defined below) – main pipe to convey water for fire brigade use to all floors of a *building* and where appropriate to the roof. A *riser main/system* must consist of either a *wet riser main system* or a *charge dry riser main system*.

Riser – the height between consecutive treads and between each *landing* and continuous tread.

SECTION A -GENERAL PROVISIONS

Runoff – amount of rainfall that does not percolate into soil and becomes perched on the ground-surface.

Safety Glass – toughened or laminated glass or had a safety film applied to it so that it resists shattering upon impact, is certified by a *Registered Testing Authority* and bears identification markings indicating that the pane has been cut from safety glass material.

Sanitary Compartment – a room or space containing a toilet fixture, closet pan, soil pan, chemical toilet, or the like.

Sanitary Fixture – any receptacle or apparatus that receives clean, potable water and is used for domestic cleansing, including sinks, showers, bathtubs, hot tubs, laundry tubs and associated taps, stoppers and overflow mechanisms, and accessories such as towel racks, automatic hand dryers, soap dispensers, etc.

Sarking-type Material – a material such as a reflective foil or other flexible membrane of a type normally used for a purpose such as waterproofing, vapour proofing or thermal reflectance.

School – includes a primary or secondary *school*, college, university or similar educational establishment.

Self-closing – applied to a door or *window* means equipped with a device which returns the door or *window* to the fully closed and latched position immediately after each manual opening.

Service – a mechanical or electrical system that uses energy to provide air conditioning, mechanical ventilation, heated water supply, artificial lighting, vertical transport and the like within a *building*, but which does not include:

- (a) Systems used solely for emergency purposes;
- (b) Cooking facilities; and
- (c) Portable appliances.

Service Station – a garage which is not a *private garage* and is for the servicing of vehicles, other than only washing, cleaning or polishing.

Sewage – waterborne human waste from domestic and commercial premises including faeces and urine, and waste room kitchens, showers, baths, domestic laundries etc.

Sewer – a conduit vested in a public authority and located outside the property boundary. It is used for the conveyance of *wastewater*.

Separating Element – a barrier that exhibits fire integrity, structural adequacy, insulation, or a combination of these for a period of time under specified conditions (often in accordance with AS 1530.4).

Separating Wall – a wall that is common to adjoining Class 1 *building*.

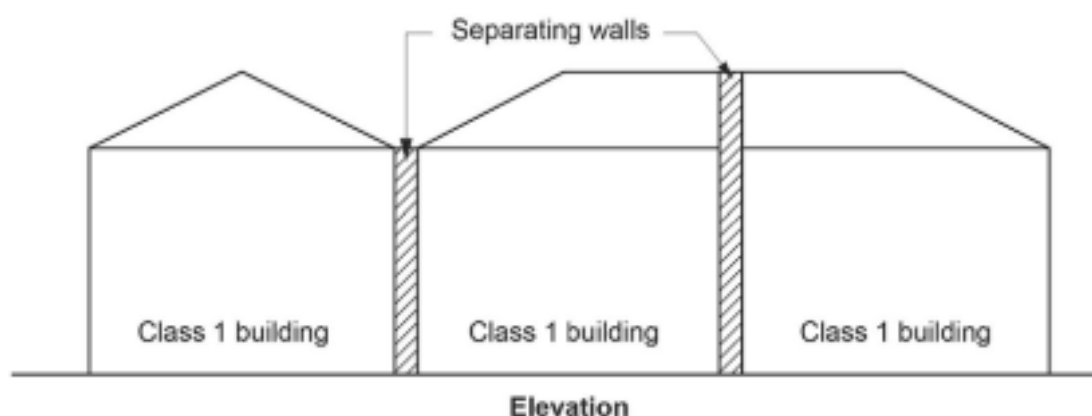

Shaft – the walls and other parts of a *building* bounding:

- (a) A well, other than an *atrium* well; or
- (b) A vertical chute, duct or similar passage, but not a chimney or flue.

SECTION A -GENERAL PROVISIONS

Significant Alteration – proposed *alterations* of greater than 50% of the mass of structural elements or gross floor area (whichever is less) of an existing *building*, and in which case the entire *building* shall be made compliant to the requirements of this code. Extensions to an existing *building* exceeding 40 m² but less than 50% of the existing plan size shall comply with this code. For extensions greater than 50% of the existing floor area, the entire *building* must be made good to comply with this code.

Site – the part of the allotment of land on which a *building* stands or is to be erected.

Sitework – work on or around a site, including earthworks, preparatory to or associated with the construction, *alteration*, demolition or removal of a *building*.

Sludge – semi-liquid solids settled from wastewater.

Smoke-and-heat Vent – a vent, located in or near the roof for smoke and hot gases to escape if there is a fire in the *building*.

Smoke-Developed Index – the index number for smoke developed under AS 1530.3.

Soil Fixture – a water closet pan, urinal, sanitary napkin disposal unit, slop hopper, bed pan washer or autopsy table.

Soil Pipe – a pipe which conveys discharge from *Soil Fixtures*.

Sole-occupancy Unit – a room or other portion of a *building* for occupation by one owner, lessee, tenant, or other occupier to the exclusion of any other owner, lessee, tenant, or other occupier.

Spread-of-flame index – the index number for spread of flame under AS 1530.3.

Stack – a vertical *drain* including offsets and extending to more than one *storey*.

Stage – a floor or platform in Class 9b *building* on which performances are presented before an audience.

Standard Fire Test – the Fire-resistance Test of Structures under AS 1530.4.

Storey – a space within a *building* which is situated between one floor level and the floor level next above, or is there is no floor above, the ceiling or roof above, but not:

- (a) a space that contains only:
 - 1. a lift *shaft*, stairway or meter room;
 - 2. a bathroom, shower room, water closet, or other *sanitary compartment*;
 - 3. 3 vehicles or less; or
 - 4. a combination of the above; or
- (b) a mezzanine floor.

Structural Adequacy – in relation to an FRL means the ability to maintain stability and adequate *loadbearing* capacity under AS 1530.4.

Structural Member – a component or part of an assembly which provides vertical or lateral support to a *building* or structure.

Storm Surge – a rise in sea level over and above the predicted astronomical tide generated by a storm or tsunami.

Stud – an upright support in the wall of a *building* facility to which sheathing, drywall, etc. are attached.

Sweep Junction – a long radius bend entering a main pipe at 45° or a 45° junction fitted with a 45° bend.

Swimming Pool – any excavation or structure containing water and used for swimming, wading, paddling, or the like, including a bathing or wading pool, or spa.

Tactile Ground Surface Indicators (TGSIs) – TGSIs are textured ground surface features that provide important orientation and hazard warnings for people who are blind or have low vision. There are two main types:

- (a) Warning TGSIs: Indicate a hazard ahead (e.g., stairs, ramps, platform edges).

SECTION A -GENERAL PROVISIONS

(b) Directional TGSIs: Guide users along a safe path, especially in open spaces. They must be slip-resistant, have high luminance contrast, and follow specific design standards such as spacing, height, and layout.

Trade Waste – waterborne waste from business, trade or manufacturing process containing predominantly non-human waste, but not unpolluted water.

Traditional Building Materials – Dwelling house built using traditional methods and substantially from traditional materials where not more than 12 people will be ordinarily resident.

Universal Design – Products, environments, programs, and services to be usable by all people, to the greatest extent possible, without the need for adaptation or specialized design. It aims to create inclusive spaces that accommodate the widest range of users, regardless of age, ability, or status.

Ward Area – that portion of a *storey* of a Class 9a *building* for residing patients and includes areas for sleeping, recreation and sanitary facilities, and nurses' stations.

Waste Fixture – a sanitary fixture other than a *soil fixture*. Examples are basins, bidets, kitchen sinks, laundry troughs, etc.

Waste Pipe – a pipe which conveys the discharge from *waste fixtures*.

Wastewater – dissolved and suspended waterborne waste which may consist of *sewage and/or trade waste*.

Waterproof – the complete and total resistance of a *building element* or material to the ingress of moisture.

Water Table – level of groundwater in soil and rock, below which the ground is saturated.

Weathertight – the resistance of a *building* to the weather where water and wind are prevented from entering and accumulating behind the cladding in amounts that can cause undue dampness or damage to the *building*.

Wet Area – an area within a *building* having water supplied from a water supply system which includes bathrooms, showers, laundries and sanitary compartments (excludes kitchens, bar and beverage preparation areas).

Wet Riser Main System – one or more *riser mains* in a *building* with all *required* fittings, permanently charge with water from a *fire main*. The term includes all associated pipe work from the point of connection to a *fire main*.

Window – includes a roof light, glass panel, glass brick, glass louvre, glazed sash, glazed door, or other device which transmits natural light directly from outside a *building* to the room concerned when in the closed position.

A3.2 Referenced Documents

Documents referenced in the VNBC shall refer to primary referenced documents with the edition listed in Specification A3.3.1 – Standards Adopted by Reference.

Documents referenced in primary referenced documents is a reference to secondary referenced documents as it existed at the time of publication of the primary referenced document.

Documents referenced in the VNBC and listed in Specification A3.3.1 are only applicable in the context in which they are quoted; and are mandatory to *Deemed-to-Satisfy Provisions*, Specifications and Verification Methods.

Building materials, products, forms of construction and design methods not covered by referenced documents shall provide a Performance Solution. Performance Solutions can use any element or edition of any document and are not required to use documents listed in Specification A3.3.1. Documents published by Standards New Zealand and Standards Australia shall be the primary source, with documents published by other internationally recognized standards organizations serving as secondary sources when no New Zealand or Australian document exists.

A3.3 Referenced Standards, etc.

A reference to a document under A3.2 refers to the latest edition or issue, together with any amendment, listed in Specification A3.3.1, Standards Adopted by Reference, and only so much as is relevant in the context in which the document is quoted.

A3.4 Differences between Referenced Documents and this Code

- (a) The VNBC requirements shall take precedence when differences arise between the VNBC, primary referenced documents, and secondary referenced documents.
- (b) When referenced documents require compliance with laws and regulations of another country, the laws and regulations of the Republic of Vanuatu shall take precedence. If laws and regulations of Vanuatu do not exist for the subject area, the relevant Authority shall be notified, and guidance sought.

A3.5 Mandatory Provisions

- (a) The following provisions of the Code are mandatory:
 - (i) all provisions of Section A; and
 - (ii) the *Performance Requirements* stated at the beginning of all the other Sections.
- (b) The *Deemed-to-Satisfy Provisions* of the Code are one means of satisfying the *Performance Requirements*. The *Performance Requirements* can also be met by any other means. When this latter approach is taken, it must meet the final objectives and performance that would have been achieved had the *Deemed-to-Satisfy Provisions* been followed.

A3.6 Adoption of Referenced Documents

The VNBC does not require compliance with contractual matters or clauses relating to rights, responsibilities or obligations between parties, submission requirements, and/or departure from the VNBC that may be contained within referenced documents. This includes but is not limited to:

- (a) The respective rights, responsibilities or obligations between the manufacturer, supplier or purchaser.
- (b) The responsibilities of any tradesperson or other building operative, architect, engineer, authority, or other person or body.
- (c) The submission for approval of any material, building component, form or method of construction, to any person, authority or other body.
- (d) The submission of a material, building component, form or method of construction, or design to any person, authority or body for opinion.
- (e) Departure from the VNBC, rule, specification or provision at the sole discretion of the manufacturer or purchaser, or by arrangement or agreement between the manufacturer and purchaser.

A4 Acceptance of Design and Construction

A4.1 Suitability

Every part of a *building* installed must be constructed to achieve the VNBC requirements using appropriate materials, products, forms of construction and design methods that are fit for their intended purposes considering strength, durability, and the operations & maintenance context.

Materials, products, forms of construction or design are fit for purposes when they satisfy the following:

- (a) supported by evidence of suitability as per A4.2; and
- (b) constructed or installed in an appropriate manner.

A4.2 Evidence of Suitability

Evidence of Suitability to support the use of a material, product, form of construction or design method satisfies a *Performance Requirement* or *Deemed-to-Satisfy Provision* may be in the form of any one or combination of the following:

- (a) a current BRANZ or ABCB CodeMark *Certificate of Conformity*;
- (b) a current Certificate of Accreditation;
- (c) a current certificate issued by a *certification body*;
- (d) a report issued by an Accredited Testing Laboratory;
- (e) a report issued by a *Local Testing Laboratory* recognized by the national authority having jurisdiction;
- (f) a certificate or report from a professional consultant or other appropriately qualified person;
- (g) a Product Technical Statements; or
- (h) another form of documentary evidence.

Evidence of suitability for any product that is in contact with drinking water must comply with AS/NZS 4020 and have a weighted average lead content of not more than 0.25% verified in accordance with NSF/ANSI/CAN 372, and may be in the form of any one or combination of the following:

- (a) A report issued by an Accredited Testing Laboratory;
- (b) A WaterMark license.

Evidence of suitability shall clearly demonstrate that it fulfills the specific requirements of the VNBC; and provides as required all necessary results of tests, methodologies, protocols, basis, calculations, and relevant standards, specifications, rules, codes or practices, and other publications used to demonstrate compliance with the VNBC requirements.

Evidence must be a complete copy of the original certificate, report, or document.

A4.3 Fire Hazard Properties

Where a *Deemed-to-Satisfy Provision* requires a fire hazard property, it must be determined as follows:

- (a) The Fire Resistance Level (FRL) of a *structural member* or other *building element* must be determined in accordance with **Specification A4.3.1 – Fire Resistance of Building Elements**. Any relevant testing report or certification must be published by an appropriately qualified *professional consultant* or other *appropriately qualified person* or *Accredited Testing Laboratory*.
- (b) Early Fire Hazard Tests of a component or assembly must be determined in accordance with **Specification A4.3.2 – Early Fire Hazard Test for Assemblies**. Any relevant testing or certification must be published by an appropriately qualified *professional consultant* or other *appropriately qualified person* or *Accredited Testing Laboratory*.
- (c) References to Fire Resistance Rating (FRR) in reference documents issued by Standards Australia and Standards New Zealand shall mean FRL.

Noting that the specifications provide a list of non-mandatory standards that are to be used as the basis for measuring against all other standards that are proposed to satisfy *Performance Solutions*.

A4.4 Material Durability

Building materials, components and construction methods shall be sufficiently durable to ensure that the *building*, without reconstruction or major renovation, satisfies the other functional requirements of this Code throughout the *design life* of the *building*.

In particular:

- (a) Unless exempted under Clause A 4.5, all locally grown plantation timber or imported timber used for structural applications shall be treated to a minimum of H3.2 (as per NZS 3602) or otherwise satisfy Clause A2.5.
- (b) all non-structural timber shall be treated to a minimum of H1.2 (as per NZS 3602) or brushed with a suitable timber treatment wood preservative.

(c) Manufacture, grading, finishing and branding of all structural plywood shall comply with AS/NZS 2269.0 Plywood-Structural Part 0: Specifications.

A4.5 Use of Locally Grown Timber

- (a) The use of locally grown timber is prohibited except when legally permitted by the Department of Forestry and the *Approval Authority* to use locally grown timbers for non-structural and/or structural purposes; and
- (b) Evidence of suitability as per A4 has been submitted to the *Approval Authority*; and
- (c) The Timber Properties: Vanuatu Timber Properties Handbook, 24 Commercial Species dated June 1998 used in conjunction with AS 2082-1979 has been used for design.

A4.6 Documentation

All submitted documents to support the use of a material, product, form of construction or design shall be:

- (a) in English or French;
- (b) in metric units;
- (c) of sufficient clarity to indicate the location, nature and extent of work proposed and with sufficient detail to show that the *Performance Requirements* and provisions of the VNBC, laws, ordinances, rules, and regulations have been satisfied; and
- (d) of sufficient clarity to indicate the code, standards, occupancy, importance level, fire resistance levels, material strengths, and design actions.

A5 Classification of Buildings & Structures

A5.1 Principles of Classification

The classification of a *building* or part of a *building* is determined by the purposes for which it is designed, constructed or adapted to be used.

Each part of a *building* must be classified according to its purpose and comply with all the appropriate requirements for its classification.

A room that contains a mechanical, thermal or electrical facility or the like that serves the *building* must have the same classification as the major part or principal use of the *building* or fire compartment in which it is situated

Unless another classification is more suitable an occupiable outdoor area must have the same classification as the part of the *building* to which it is associated.

Where it is unclear which classification should apply, the *Approval Authority* has the discretion to decide.

[NOTE: the following building classification descriptions and diagrams have been adopted from the Australian Building Codes Board publication 'Building Classifications', July 2020, abcb.gov.au]

A5.2 Building Classifications

Building classifications are labelled "Class 1" through to "Class 10". Some classifications also have sub-classifications, referred to by a letter after the number (e.g. Class 1a).

A *building* may have parts that have different uses. In most cases, each of these parts are classified separately.

A *building* (or part of a *building*) may also have more than one use and may be assigned more than one classification.

Buildings are classified as follows:

SECTION A -GENERAL PROVISIONS

Class 1 Buildings

Class 1 *buildings* are houses. Typically, they are standalone single dwellings of a domestic or residential nature.

These *buildings* can also be horizontally attached to other Class 1 *buildings*. When attached they are commonly referred to as duplexes, terrace houses, row houses and townhouses. In these situations, they must be separated by a wall that has fire-resisting and sound insulation properties.

The Class 1 classification includes two sub-classifications: Class 1a and Class 1b.

A **Class 1a building** is a single dwelling being a detached house; or one of a group of attached dwellings being a town house, row house or the like.

A **Class 1b building** is a boarding house, guest house or hostel that has a floor area less than 300 m² and ordinarily has fewer than 12 people living in it. It can also be four or more single dwellings located on one allotment that are used for short-term holiday accommodation.

Class 1 buildings cannot be located above or below any other dwelling (or any other class of building) other than a private garage.

Class 2 Buildings

Class 2 *buildings* are apartment *buildings*. They are typically multi-unit residential *buildings* where people live above and below each other.

Class 2 *buildings* may also be single *storey* attached dwellings where there is a common space below. For example, two dwellings above a common basement or carpark.

Is it a Class 1b, 2 or 3 residential building? Classification is a process for understanding risk in a building (or part of a building) according to its use. Where it is unclear which classification should apply, the *Approval Authority* has the discretion to decide.

Class 3 Buildings

Class 3 applies to residential *buildings* other than Class 1 or Class 2 *buildings*, or a Class 4 part of a *building*. Class 3 *buildings* are a common place of long term or transient living for a number of unrelated people. Examples include a boarding house, guest house, hostel or backpackers (that are larger than the limits for a Class 1b *building*).

Class 3 *buildings* could also include dormitory style accommodation, or workers' quarters. Class 3 buildings may also be "care-type" facilities (such as accommodation buildings for children, the elderly, or people with a disability) which are not Class 9 *buildings*.

Class 3 includes residential care buildings and the residential parts of hotels, motels, schools, or jails.

Class 4 Part of a Building

A Class 4 part of a *building* is a sole dwelling or residence within a *building* of a non-residential nature. An example of a Class 4 part of a *building* would be a caretaker's residence in a storage facility. A Class 4 part can only be located in a Class 5 to 9 *building*.

Is it the only residence in the building? If so, then it is likely to be a Class 4 part of a building. There can only be one Class 4 part in a building. A Class 4 part cannot be located in a Class 1, 2 or 3 building.

Class 5 Buildings

Class 5 *buildings* are office *buildings* used for professional or commercial purposes. Examples of Class 5 *buildings* are offices for lawyers, accountants, government agencies and architects.

When is a general medical practitioner's office not a Class 5 building? Generally, a general medical practitioner's office will be a Class 5 building. However, if any medical treatment administered leaves patients unconscious or non-ambulatory, then the building would be considered a health-care building and therefore a Class 9a building.

Class 6 Buildings

Class 6 *buildings* are typically shops, restaurants and cafés. They are a place for the sale of retail goods or the supply of services direct to the public. Some examples are:

SECTION A -GENERAL PROVISIONS

- a dining room, bar, shop or kiosk part of a hotel or motel;
- a hairdresser or barber shop;
- a public laundry;
- a market or showroom;
- a funeral parlour; or
- a shopping center.

Is a service station a Class 6 building? Yes, as they are intended for the servicing of cars and the sale of fuel or other goods. However, the term “service station” does not cover buildings where panel beating, auto electrical, tire replacement, or the like are solely carried out. These are Class 8 buildings.

Class 7 Buildings

Class 7 *buildings* are storage-type *buildings*. The Class 7 classification has two sub-classifications: Class 7a and Class 7b.

Class 7a buildings are carparks.

Class 7b buildings are typically warehouses, storage buildings or buildings for the display of goods (or produce) that is for wholesale.

Reference to wholesale means “sale to people in the trades or in the business of ‘on-selling’ goods and services to another party (including the public)”.

Class 8 Buildings

A factory is the most common way to describe a Class 8 *building*. It is a *building* in which a process (or handicraft) is carried out for trade, sale, or gain. The *building* can be used for production, assembling, altering, repairing, finishing, packing, or cleaning of goods or produce. It includes *buildings* such as a mechanic’s workshop. It may also be a *building* for food processing, such as an abattoir. A laboratory is also a Class 8 *building*, even though it may be small. This is due to the high fire hazard potential.

Class 9 Buildings

Class 9 *buildings* are *buildings* of a public nature. The Class 9 classification has three sub-classifications: Class 9a, Class 9b and Class 9c.

Class 9a buildings are generally hospitals, referred to in the Code as *healthcare buildings*. They are *buildings* in which occupants or patients are undergoing medical treatment and may need physical assistance to evacuate in the case of an emergency. This includes a clinic (or day surgery) where the effects of the treatment administered involve patients becoming unconscious or unable to move. This in turn requires supervised medical care (on the premises) for some time after treatment has been administered.

Class 9b buildings are *assembly buildings* in which people may gather for social, theatrical, political, religious or civil purposes. They include schools, universities, childcare centers, pre-schools, sporting facilities, night clubs, or public transport *buildings*.

Class 9c buildings are residential care buildings that may contain residents who have various care level needs. They are a place of residence where 10% or more of persons who reside there need physical assistance in conducting their daily activities and to evacuate the *building* during an emergency. An aged care *building*, where residents are provided with personal care services, is a Class 9c *building*.

Laboratories that are part of healthcare buildings are classified as Class 9a buildings, despite the general classification of laboratories being Class 8.

Class 10 Buildings

Class 10 *buildings* are non-habitable *buildings* or structures. Class 10 includes two sub-classifications: Class 10a and Class 10b.

Class 10a buildings are non-habitable *buildings*, including sheds, carports, and private garages.

Class 10b is a structure being a fence, mast, antenna, retaining wall, swimming pool, or the like.

What is a private garage? A garage associated with a Class 1 building; or a single *storey* of a building containing not more than 3 vehicle spaces (limited to only one *storey* within a building); or any separate single-*storey* garage associated with another building that contains no more than 3 vehicles.

Mixed use buildings

As *buildings* can have mixed uses, they can also have mixed (or multiple) classifications. For example, a building may have a basement carpark (Class 7a) with ground floor retail space (Class 6) and residential apartments (Class 2) and offices above (Class 5).

How big must a part of a building be to have its own classification?

Every part of a building must be separately classified. However, where a part has a different purpose and is not more than 10% of the floor area of the *storey* it is on, subject to some limitations it may be considered ancillary to the major use and adopt its classification. For instance, if a single-*storey* warehouse (Class 7b) has an office (normally Class 5) that takes up only 8% of the floor area, the whole building can be classified as Class 7b. However, if the office takes up 12% of the floor area, then the warehouse (Class 7b) and office (Class 5) must be classified separately.

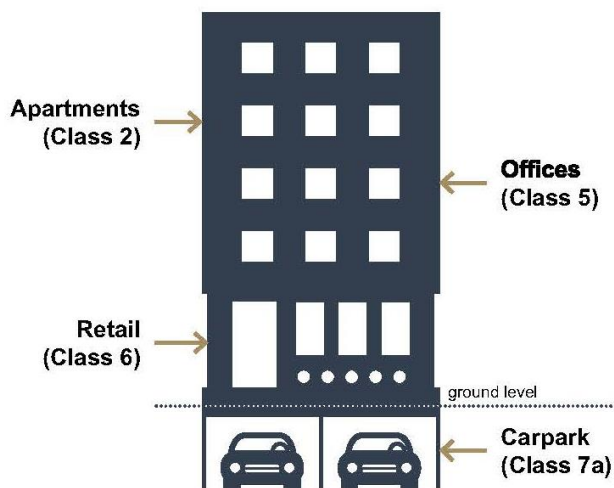

A5.3 Multiple Building Classifications

A *building* (or a part of a *building*) may be designed to serve multiple purposes and may have more than one classification. This means that it is permissible for a building to be Class 6/7, or Class 5/6, or whatever is deemed appropriate. This allows flexibility in how the building might be used. For example, if a building is intended for retail shopping, storage or office space, it may be designed as a Class 5/6/7 building.

At the design stage, it may not be clear who the final tenant will be (or how they will be using their tenancy), so as long as the design meets the minimum requirements of all the classifications it could be used for any of the purposes.

A6 United Buildings

A6.1 United Buildings

Two or more *buildings* adjoining each other are considered to form one united *building* if they are connected through openings in the walls dividing them and used as one building.

United *buildings* shall comply with all the requirements of the VNBC as though they are a single *building*.

In the case of a united *building* comprised of *buildings* of different classes, the most restrictive fire resistance requirements of pertinent classes of the individual *building* shall apply.

A6.2 Alterations in a United Building

If, after *alterations* or any other *building work*, two or more of the *buildings* in a United Building cease to be connected through openings in the dividing walls, each of those *buildings* not now connected must comply with all the requirements for a single *building*.

A7 Building Importance Level

A7.1 Building Importance Level

1. The Importance Level of a *building* or structure shall be determined in accordance with its occupancy and uses, as given in Tables A7.1 and A7.2.
2. *Buildings* and structures that have multiple uses shall be assigned the highest importance level applicable for any of those uses.
3. Where an adjacent structure provides access to another structure with higher importance level, then the structure providing access shall be designated the same importance level as the structure to which it provides access.
4. *Buildings* or structures that supply infrastructure services (power, water, etc.) to higher importance level *buildings* or structures shall be designated the same importance level as the structure to which it provides services to.
5. *Buildings* and structures having high community value, or provide essential community services that cannot be replaced rapidly following a natural or manmade event, or geographically isolated or inaccessible, or have low accessibility to resources for maintenance, and/or will be challenged to recover rapidly following a natural or manmade event shall be designated a Building Importance Level 3 or 4 depending on its consequence of failure within that community.
6. The *Approval Authority* shall make all final determinations on Importance Level based on information submitted.

Table A7.1 Consequences of Failure for Importance Levels – Vanuatu

Consequences of failure	Description	Importance level	Comment
Low	Low consequence for loss of human life or small or moderate economic, social or environmental consequences.	1	Minor Structures (failure not likely to endanger human life).
Ordinary	Medium consequences for loss of human life, or considerable economic, social or environmental consequences.	2	Normal Structures or structures not falling into other levels.
High	High consequence for loss of human life or very great economic, social or environmental consequences. High difficulties for community to recover post-disaster and high difficulties to maintain. Structures having high community value. Structures that provide essential community services that cannot be replaced rapidly following a natural or manmade event. Geographically isolated or inaccessible structures. Structures that have low maintenance regimes. Structures with a potential to cause substantial local or national economic impact and/or mass disruption of day-to-day civilian life.	3	Major Structures (affecting crowds) & Essential Community Services.
		4	Post-Disaster Structures (Post-Disaster Functions or Dangerous Activities). Hazardous Facilities. Highly Essential Community Services. Designated Essential Facilities.
Exceptional	Circumstances where reliability must be set on a case-by-case basis.	5	Exceptional Structures (beyond the scope of this Code)

SECTION A -GENERAL PROVISIONS

Table A7.2 Importance Levels for Building Types – Vanuatu Structures (amend AS/NZS 1170.0:2002)

Importance level	Description of Building Type	Specific Structure Examples
1	<i>Buildings</i> posing low risk to human life or the environment, or a low economic cost, should the building fail. These are typically small non-habitable buildings, such as sheds, barns, and the like, that are not normally occupied, though they may have occupants from time to time.	Ancillary <i>buildings</i> not for human habitation. Minor storage facilities.
2	<i>Buildings</i> posing normal risk to human life or the environment, or a normal economic cost, should the <i>building</i> fail. These are typical residential, commercial, and industrial <i>buildings</i> .	<i>Buildings</i> not included in Importance Levels 1, 3, or 4. Single family dwellings. Car parking <i>buildings</i> .
3	<i>Buildings</i> of a higher level of societal benefit or importance, or with higher levels of risk-significant factors to building occupants. These <i>buildings</i> have increased performance requirements because they may house large numbers of people, vulnerable populations, or occupants with other risk factors, or fulfil a role of increased importance to the local community or to society in general.	<i>Buildings</i> and structures that are isolated, have low accessibility to resources for maintenance, and/or will be challenged to recover rapidly following a hazard event. <i>Buildings</i> where more than 300 people can congregate in one area. Churches where more than 300 people can congregate, but not designated as an evacuation center or emergency shelter. Any <i>building</i> with a capacity of 1,000 or more people. Daycare facilities with a capacity greater than 150. Primary school or secondary school facilities with a capacity greater than 250 people. Colleges or adult education facilities with a capacity greater than 250. Health care facilities with a capacity of 50 or more resident patients but not having surgery or emergency treatment facilities. Airport terminals with a capacity greater than 200. Jails, detention facilities, and correctional institutions. Public <i>assembly buildings</i> , theaters and cinemas of greater than 1,000 m ² . Emergency medical and other emergency facilities not designated as post-disaster. Power-generating facilities, water treatment and wastewater treatment facilities and other public utilities not included in Importance Level 4 nor designated as post-disaster. Bank and cash distribution facilities and structures.

SECTION A -GENERAL PROVISIONS

Importance level	Description of Building Type	Specific Structure Examples
		<p>Food distribution and warehouse facilities larger than 50 m².</p> <p><i>Buildings</i> not included in importance Level 4 containing enough highly toxic or explosive materials capable of causing acutely hazardous conditions that do not extend beyond the property boundaries.</p>
4	<p><i>Buildings</i> that are essential to post-disaster recovery or associated with hazardous facilities.</p>	<p><i>Buildings</i> and facilities with special post-disaster or recovery function and/or designated as essential facilities or critical infrastructure.</p> <p>Hospitals and health care facilities having surgery or emergency treatment.</p> <p>Emergency services facilities such as fire, rescue, police stations, warehouses/storage, garages and other supporting buildings having an emergency, recovery, and/or national defense function.</p> <p><i>Buildings</i> and facilities owned by government that provide essential services.</p> <p><i>Buildings</i> intended by the owner to contribute to emergency preparedness, or to be used for communication, and operation centers in an emergency, and other facilities required for emergency response.</p> <p>Designated emergency shelters, designated emergency centers and ancillary facilities.</p> <p>Churches designated as evacuation centers or emergency shelters.</p> <p>Power generating stations, water treatment facilities, and other utilities required as emergency backup facilities for importance level 4 structures.</p> <p><i>Buildings</i> and structures that are highly isolated, have very low accessibility to resources for maintenance, and/or will be highly challenged to recover rapidly following a hazard event.</p> <p>Aviation and port <i>buildings</i>, warehouses, and hangers that are critical to maintaining immediate aviation operations.</p> <p>Ancillary <i>buildings</i> (including, but not limited to, communication towers, fuel storage tanks or other structures) required for operation of importance level 4 structures during an emergency.</p> <p><i>Buildings</i> housing highly toxic gas or explosive materials capable of causing acutely hazardous conditions that extend beyond property boundaries.</p>
5	<p>Special structures (for structures outside the scope of the building code acceptable probability of failure to be determined by special study)</p>	<p>Structures that have special functions or whose failure poses catastrophic risk to a large area (e.g., 100 km²) or a large number of people (e.g., 100,000)</p> <p>Major dams, extreme hazard facilities</p>

A7.2 Building Design Life

The *design life* of a *building*, facility, or *building element* is the period of use as intended by the designer after which it may need to be replaced. Before this period has elapsed, it should remain fit for purpose.

The *design life* for normal structures is generally taken as 50 years. *Design life* will vary according to the type and use of the element being considered. The below list gives indicative design lives for various types of structure:

Category 1: Temporary structures, not including structures or parts of structures that can be dismantled with a view to being reused – 10 years.

Category 2: Replaceable structural parts, e.g. gantry girders, bearings – 10 to 25 years.

Category 3: Agricultural and similar *buildings* – 15 to 30 years.

Category 4: *Building* structures and other common structures – 50 years.

Category 5: Monumental *building* structures, bridges and other civil engineering structures – 100 years.

Importance Level 3, Importance Level 4, *Schools*, *Healthcare Buildings*, and buildings providing essential community or government services shall not be designed for less than a 50-year design life.

A8 UXO Survey and Disposal

A8.1 UXO Definitions

For the purposes of this Code, the following definitions shall be used when referring to UXOs:

UXO – all unexploded ordnance (UXO) whether abandoned or unexploded, including but not limited to artillery, mortar, rocket, and small arms ammunition, as well as bombs, landmines, sea mines, torpedoes, depth charges and propellant actuated devices.

UXO Risk Assessment – the evaluation aimed at determining the potential hazards and risks associated with unexploded ordnance at a specific site. The initial risk assessment determines the need for and level of survey required. Risk Assessments can be supplemented by site specific UXO Surveys.

UXO Survey – a systematic process designed to detect, identify, and map UXOs left behind from military activities at specific sites. Surveys may be non-intrusive or intrusive based on the specific requirements of the project and the level of risk involved. The primary goal is to minimize the risk to personnel and the public by identifying and safely removing UXOs as much as practically possible. UXO Surveys and subsequent clearance does not guarantee that the site is completely clear of UXOs; UXOs may be discovered during *building works*.

A8.2 UXO Risk Assessment, Survey Type, and Clearance

Risk Assessment and Survey Type – Where *building work* requires any geotechnical investigation, earthmoving, or *building works*, the *Approval Authority* will determine whether an initial UXO risk assessment is required (based on the history of the site and historical records) and what type of survey is appropriate. Initial Risk Assessment, Detailed Risk Assessments and Surveys shall be performed by the Vanuatu Mobile Force (VMF) and/or a technically competent UXO survey and remediation organization approved by VMF and the *Approval Authority*. The initial UXO Risk Assessment shall be performed during the earthmoving, *building permit*, and/or planning application.

UXO Identification and Clearance During Survey or Building Works – If a UXO is discovered during the UXO Survey or *building works*, the location shall be clearly marked/identified and isolated; local authorities, government agencies, and VMF responsible for public safety and UXO clearance shall be immediately notified; and local populations informed. *Building works* and access to the site shall cease and all personnel shall move to a safe distance until clearance has been performed. VMF and/or technically competent UXO Survey and remediation organization shall identify the type of UXO; recommend a method of isolation, neutralization, and/or removal; coordinate resources as required; and provide written instructions, updates, and appropriate communications outreach to all stakeholders. VMF shall lead the UXO clearance process. *Building works* may continue once clearance has been performed or as permitted by VMF through written instructions.

A9 Prevention and Control of Asbestos

A9.1 Asbestos Definitions

For the purposes of this Code, the following definitions shall be used when referring to asbestos:

Asbestos – means any of the following asbestiform varieties:

- (a) asbestos actinolite; or
- (b) asbestos grunerite (amosite) (brown asbestos) (cummingtonite-grunerite); or
- (c) asbestos anthophyllite; or
- (d) asbestos chrysotile (white asbestos) (serpentine); or
- (e) asbestos crocidolite (blue asbestos) (riebeckite); or
- (f) asbestos tremolite; or
- (g) a mixture that contains one or more of the above.

Asbestos Management Code of Practice – the Vanuatu Asbestos Management Code of Practice including amendments or supplementary guidance documents.

Asbestos-containing material – any goods, material or thing, including waste material and soil, containing more than 1% asbestos by weight.

Asbestos waste – any waste that contains asbestos or asbestos-containing material.

Recycling – any operation by which asbestos waste is reprocessed into products, materials or substances whether for the original or other purposes.

Re-use – any operation by which asbestos waste is used again for the same purpose for which that asbestos or asbestos-containing material was originally intended.

A9.2 Prohibition on the Importation, Re-use, Fabrication and Recycling of Asbestos and Asbestos-containing Materials in Buildings

Any *building* or *building element* in Vanuatu is prohibited to use asbestos or asbestos-containing materials that is imported, used, re-used, fabricated or recycled for use.

A9.3 Removal and Disposal of Asbestos or Asbestos-containing Materials

- (1) The removal of asbestos or asbestos-containing material shall be considered asbestos waste and must be removed and disposed according to:
 - (a) the specified Acts;
 - (b) the specified Regulations;
 - (c) the Vanuatu Asbestos Management Code of Practice;
 - (d) other approved code of practice or standard;
 - (e) other requirements of the Approval Authority and other Authorities;
 - (f) the Asbestos Removal Control Plan.
- (2) Disturbance of asbestos or asbestos-containing materials shall be managed in accordance with the requirements in (1).
- (3) Contractors approved by the Approval Authority to remove and dispose of asbestos or asbestos-containing materials shall do so in accordance with the requirements in (1).

A10 Health and Safety at Work

The Health and Safety at Work Act and any approved Code of Practices shall be complied with during

the construction of a *building*, structure, or part; including any associated construction or maintenance activities; including after the *building* has been built. The Health and Safety at Work Act [CAP 195] shall apply throughout the *building's design life*. Compliance checks with the Health and Safety at Work Act [CAP 195] shall be performed by the *Approval Authority*, or their designated agent, following any damaging event or conditions as describe in Part B2.3 Dangerous Buildings.

A11 Universal Design Principles

Part ND3 – Access for People with Disabilities references *universal design principles* that will be mandatory for all Class 3, 5, 6, 7, 8, and 9 *buildings*. While for Class 1, 2, 4, and 10 *buildings* it is not mandatory to provide access for people with disabilities, note should be taken of the guidelines set out in the Australian Department of Foreign Affairs (DFAT): Accessibility Design Guide: Universal Design principles for Australia's Aid Program – Annex E; Housing – (Available free of charge from the DFAT website).

Buildings shall consider the diversity of impairments for persons with disabilities—not just one or two types. Inclusive design should address the needs of people with physical, sensory, cognitive, and psychosocial disabilities to ensure accessibility for everyone.

SPECIFICATION A3.3.1

Standards Adopted by Reference

The Standards and other documents listed in Table 3.3.1 are referred to in this Code. In order to reduce possible confusion/conflict, the Standards produced by the Standards Australia or by Standards New Zealand as seen to be specifically relevant, have been called up. However, users of the Code are free to use any suitable mix of regional Standards provided care is taken to follow consistent technical principles and prevalent practices. Where regional Standards do not cover any specific area, the relevant Standards as may be approved by the *Approval Authority* should be used.

Table 3.3.1: Scheduled Referenced Documents

No.	Title	Code clause
AS/NZS 1170.0	Structural design actions, Part 0: General Principles	B1.2, B1.3
AS/NZS 1170.1	Structural design actions, Part 1: Permanent, imposed and other actions	B1.3, B1.6
AS/NZS 1170.2	Structural design actions, Part 2: Wind actions	B1.3
NZS 1170.5	Structural design actions, Part 5: Earthquake actions - New Zealand	B1.3
AS/NZS 1221	Fire hose reels	NE1.4
AS 1288	Glass in buildings – Selection and Installation	B1.4
AS 1530.1	Methods for fire tests on building materials, components and structures – Part 1: Combustibility test for materials	Spec A5.3
AS 1530.2	Methods for fire tests on building materials, components and structures – Part 2: Test for flammability of materials	Spec A5.3
AS/NZS 1530.3	Methods for fire tests on building materials, components and structures – Part 3: Simultaneous determination of ignitability, flame propagation, heat release and smoke	Spec A5.4,
AS 1530.4	Methods for fire tests on building materials, components and structures, Part 4: Fire-resistance tests for elements of construction	Spec A5.4, Spec NC3.15
AS/NZS 1546.1	On-site Domestic Wastewater Treatment Units – Part 1: Septic Tanks	DF7.2
AS/NZS 1547	On-site domestic wastewater management	DF7.6
AS 1562.1	Design and Installation of metal roof and wall cladding, Part 1: Metal	B1.4

SECTION A -GENERAL PROVISIONS

No.	Title	Code clause
AS 1657	Fixed platforms, walkways, stairways and ladders – Design, construction and installation	ND2.18
AS/NZS 1664.1	aluminum structures, Part 1: Limit state design	B1.4
AS/NZS 1664.2	aluminum structures, Part 2: Allowable stress design	B1.4
AS 1668.1	The use of ventilation and air conditioning in building, Part 1: Fire and smoke control in buildings	NC3.15, NE2.7, Spec NE1.7, NH 1.2, NE5.2
AS 1668.2	The use of ventilation and air-conditioning in buildings, Part 2: Mechanical ventilation in buildings	DF4.5, NF4.5, NF4.17
AS 1670.1	Fire detection, warning, control and intercom systems – System design, installation and commissioning, Part 1: Fire	NE1.6, NE 4.2
AS 1670.3	Fire detection, warning, control and intercom systems – System design, installation and commissioning, Part 3: Fire alarm monitoring	Spec NE1.7, NE 2.5, NE5.2
AS 1670.4	Fire detection, warning, control and intercom systems – System design, installation and commissioning, Part 4: Emergency warning and intercom systems	Spec NE1.7, NE 2.5, Ne 5.2
AS 1670.5	Fire detection, warning, control and intercom systems – System design, installation and commissioning, Part 5: Special hazards systems	Sec NE1.7, NE 2.5
AS 1684.2	Residential timber-framed construction, Part 2: Non-cyclonic areas	B1.4
AS 1684.4	Residential timber-framed construction, Part 4: Simplified — Non-Cyclonic Areas	B1.4
AS 1720.1	Timber structures, Part 1: Design methods	B1.4
AS/NZS 1720.4	Timber structures, Part 4: Fire resistance of timber elements	B1.4, Spec A5.3
AS 1720.5	Timber structures, Part 5: Nail plated timber roof trusses	B1.4
AS 1735.1	Lifts, escalators and moving walks, Part 1: General requirements	NE3.1
AS 1735.2	Lifts, escalators and moving walks – Passenger and goods lifts – Electric	Spec NC1.5 NE3.4, NE3.1
AS/NZS 1860.1	Particleboard Flooring, Part 1: Specifications	B1.4

SECTION A -GENERAL PROVISIONS

No.	Title	Code clause
AS 1860.2	Particleboard Flooring, Part 2: Installation	B1.4
AS 1905.1	Components for the protection of openings in fire-resistant walls, Part 1: Fire-resistant door sets	Spec NC1.6, NC3.6
AS 1926.1	Swimming pool safety – Part 1: Safety barriers for swimming pools	NG 1.1
AS 1926.2	Swimming pool safety – Part 2: Location of safety barriers for swimming pools	NG 1.1
AS 1926.3	Swimming pool safety – Part 3: Water recirculation systems	NG 1.1
AS 2047	Windows and external glazed doors in buildings	B1.4
AS 2050	Installation of Roof Tiles	B1.4
AS 2159	Piling – Design and installation	B1.4
AS/NZS 2179.1	Specifications for rainwater goods, accessories and fasteners, Part 1: Metal shape or sheet rainwater goods, and metal accessories and fasteners	NF7.2
AS/NZS 2269.0	Plywood – Structural, Part 0: Specifications	B1.4
AS/NZS 2293.1	Emergency lighting and exit signs for buildings, Part 1: System design, installation and operation	NE3.5, NE3.8
AS/NZS 2312.1	Guide to the protection of structural steel against atmospheric corrosion by the use of protective coatings – Part 1: Paint coatings	B4.2
AS/NZS 2312.2	Guide to the protection of structural steel against atmospheric corrosion by the use of protective coatings – Part 2: Hot dip galvanizing	B4.2
AS/NZS 2327	Composite structures – Composite steel-concrete construction in buildings	B1.4, Spec A5.3
AS/NZS 2588	Gypsum plasterboard	Section A – Schedule 1 – Definitions
AS 2601	The demolition of structures	B2.2
AS 2665	Smoke/heat venting systems – Design, installation and commissioning	NC2.3, NE2.5, Spec NE2.6
AS/NZS 2712	Solar and Heat pump Water Heaters – Design and Construction	NF5.4

SECTION A -GENERAL PROVISIONS

No.	Title	Code clause
AS/NZS 2728	Prefinished/pre-painted sheet metal products for interior/exterior building applications – Performance requirements	B4.2
AS/NZS 2845.1	Water Supply – Backflow Prevention Devices, Part 1: Material design and performance requirements	DF5.2, NF5.2
AS 2870	Residential slabs and footings	B1.4, DF1.9, NF1.9
AS/NZS 2904	Damp-proof courses and flashings	DF1.8, NF1.8
AS/NZS 3000	Electrical installations (known as the Australian/New Zealand Wiring Rules)	DE1.1, NE5.1
NZS 3101.1&2	Concrete structures standard	B1.4
NZS 3109	Concrete construction	B1.4
NZS 3124	Specification for concrete construction for minor works	B1.4
NZS 3404	Steel Structures Standard	B1.4
AS/NZS 3500.0	Plumbing and drainage, Part 0: Glossary of terms	
AS/NZS 3500.1	Plumbing and drainage, Part 1: Water Services	DF5.2, NF5.2, NF5.3
AS/NZS 3500.2	Plumbing and drainage, Part 2: Sanitary plumbing and drainage	DF6.2, NF7.2
AS/NZS 3500.3	Plumbing and drainage, Part 3: Storm water drainage	NF7.2,
AS/NZS 3500.4	Plumbing and drainage, Part 4: Heated water services	DF5.2, NF5.3, NF5.4, NF5.2.
AS 3600	Concrete structures	B1.4, Spec A5.3
NZS 3603	Timber Structures Standard	B1.4
NZS 3604	Timber-framed buildings	B1.4, B3.3, B4.2
AS 3660.1	Termite management, Part 1: New building work	B1.4
AS 3660.2	Termite management, Part 2: In and around existing buildings and structures	B1.4
AS 3660.3	Termite management, Part 3: Assessment criteria for termite management systems	B1.4
AS/NZS 3666.1	Air-handling and water systems of buildings – Microbial control – Part 1: Design, installation and commissioning	NE 4.17

SECTION A -GENERAL PROVISIONS

No.	Title	Code clause
AS 3700	Masonry structures	B1.4, Spec A5.3
AS 3972	General purpose and blended cements	B4.3
AS/NZS 4020	Testing of products for use in contact with drinking water	A5.2
AS 4100	Steel structures	B1.4, Spec A5.3
AS/NZS 4200.1	Pliable building membranes and underlays, Part 1: Materials	DF1.5, NF1.5
NZS 4210	Masonry construction: Materials and workmanship	B1.4, Spec A5.3
NZS 4223	Glazing Standards Set: Part 1: glass selection and glazing Part 2: insulating glass units Part 3: human impact safety requirements Part 4: wind, dead, snow, and live actions	B1.4
NZS 4229	Concrete masonry buildings not requiring specific engineering design	B1.4
NZS 4230	Design of reinforced concrete masonry structures	B1.4
NZS 4232.2	Performance criteria for fire resisting enclosures – Part 2: Fire resisting glazing systems	Spec NC3.4
NZS 4503	Hand operated firefighting equipment	NE1.5, NE1.7
AS/NZS 4505	Garage doors and other large access doors	B1.4
NZS 4510	Fire hydrant systems for buildings	NE1.2, NE1.3
NZS 4512	Fire Detection and alarm systems in buildings	Spec NE1.8, NE2.5
AS 4597	Installation of roof slates and shingles (non-interlocking type)	B1.4
AS/NZS 4600	Cold-Formed Steel Structures	B1.4
AS/NZS 5033	Installation and Safety Requirements for photovoltaic (PV) arrays	DE1.3
AS 5216	Design of post-installed and cast-in fastenings in concrete	B1.4
ASCE 7	Minimum Design Loads and Associated Criteria for Buildings and Other Structures	B1.3, B1.6
ASCE 24	Flood Resistant Design and Construction	B1.6

SECTION A -GENERAL PROVISIONS

No.	Title	Code clause
ASTM E72-22	Standard Test Methods of Conducting Strength Tests of Panels for Building Construction (Available ASTM website)	Spec NC1.5
ASTM E695-03	Standard Test Method of Measuring Relative Resistance of Wall, Floor, and Roof Construction to Impact Loading (Available ASTM website)	Spec NC1.5
ISO 9223	Corrosion of metals and alloys — Corrosivity of atmospheres — Classification, determination and estimation	B4.2
DFAT	Accessibility Design Guide: Universal Design principles for Australia's Aid Program (Available free of charge form the DFAT website)	ND3.2, ND3.3, NF2.5
ABCB	ABCB Standard for Construction of Buildings in Flood Hazard Areas	B1.6
NASH	NASH Standard – Residential and Low-rise Steel Framing Part 1 or Part 2	B1.4
	SIEAPI Guidelines on Energy Efficiency	DEP3.1, NEP4.5
	Vanuatu Asbestos Management Code of Practice	A9, B2
	Vanuatu Code of Practice for Occupational Health and Safety in Construction	A10
	Vanuatu Timber Properties Handbook, 24 Commercial Species dated June 1998	A4.5

SPECIFICATION A4.3.1

Fire-Resistance of Building Elements

Contents

1. Scope	34
2. Rating	34
3. FRLs determined by calculation	34
4. Interchangeable materials	35
5. Columns covered with lightweight construction	35
Annexure to Table 1	39
1. Scope	39
2. Mortar for masonry	39
3. Gypsum blocks	40
4. Gypsum-sand mortar and plaster	40
5. Gypsum-perlite and Gypsum-vermiculite Plaster	40
6. Plaster of Cement and Sand or Cement, Lime and Sand	40
7. Plaster Reinforcement	40
8. Ashlar stone masonry	40
9. Dimensions of masonry	40
Solid Units	40
Hollow Units	40
Equivalent thickness	41
Cavity Walls	41
Cavity Walls of Different Materials	41
10. Height-to-thickness ratio of certain walls	41
11. Slenderness ratio of masonry	41
Maximum Value	41
Calculation	41
12. Protection to Masonry Reinforcement	41
13. Increase in Thickness by Plastering	41
General	41
Walls	42
14. Concrete Slabs Beams Walls and Columns	42

SECTION A -GENERAL PROVISIONS

Structural Adequacy Criterion	42
Integrity Criterion	44
Insulation Criterion	44
15. Gypsum-Perlite Or Gypsum-Vermiculite Plaster On Metal Lath	45
Walls	45
Columns	45
Beams	45
16. Exposure of Columns and Beams	45
Columns	45
Beams	45
17 Filling of Column Spaces	45
18. Reinforcement for Column and Beam Protection	46
Masonry	46
Structural Concrete	46
Gypsum-perlite or Gypsum-vermiculite Plaster Sprayed to Contour	46
19 Thickness of Column and Beam Protection	47

1. Scope

This Specification sets out the procedure for determining the Fire Resistance Level (FRL) of structural members and other *building elements*.

2. Rating

A *building element* has an FRL if:

- (a) it is listed in, and complies with Table 1 of this Section;
- (b) it is identical with a prototype that has been submitted to the *Standard Fire Test* and the FRL achieved by the prototype is confirmed in a report from a *Registered Testing Authority* which:
 - (i) describes the method and condition of test and the form of construction of the tested prototype in full; and
 - (ii) certifies that the application of restraint to the prototype complied with the *Standard Fire Test*;
- (c) it differs in only a minor degree from a prototype tested under (b) and the FRL attributed to the structural member is confirmed in a report from a *Registered Testing Authority* which:
 - (i) certifies that the structural member is capable of achieving the FRL despite the minor departures from the tested prototype; and
 - (ii) describes the materials, construction and conditions of restraint which are necessary to achieve the FRL; and
- (d) it is designed to achieve the FRL in accordance with:
 - (i) AS 4100, AS/NZS 2327 and AISC Guidelines for Assessment of Fire Resistance of Structural Steel Members if it is a steel or composite structure; or
 - (ii) AS 3600 if it is a concrete structure; or
 - (iii) AS 1720.4 if it is a solid or glued-laminated timber structure.

The FRL is determined by calculation based on the performance of a prototype in the *Standard Fire Test* and confirmed in a report in accordance with clause 3.

3. FRLs Determined by Calculation

If the FRL of a *building element* is determined by calculation based on a tested prototype:

- (a) the *building element* may vary from the prototype relation to:
 - (i) length and height if it is a wall;
 - (ii) height if it is a column;
 - (iii) span if it is a floor, roof or beam;
 - (iv) conditions of support; and
 - (v) to a minor degree, cross-section and components; and
- (b) the report must demonstrate by calculation that the *building element* would achieve the FRL if it is subjected to the regime of the *Standard Fire Test* in relation to:
 - (i) *structural adequacy* (including deflection);
 - (ii) integrity; and
 - (iii) insulation; and
- (c) the calculations must take into account:
 - (i) the temperature reached by the components of the prototype and their effects on strength and modulus of elasticity;
 - (ii) appropriate features of the *building element* such as support, restraint, cross-sectional profile, length, height, span, slenderness ratio, reinforcement, ratio of surface area to mass per unit length, and fire protection;
 - (iii) features of the prototype that influenced its performance in the *Standard Fire Test* although these features may not have been taken into account in the design for dead and live load;
 - (iv) features of the conditions of test, the manner of support and the position of the prototype during the test, that might not be reproduced in the *building element* if it is exposed to fire; and
 - (v) the design load of the *building element* in comparison with the tested prototype.

4. Interchangeable Materials

- (a) Concrete and plaster: The FRL achieved with any material of Group A, B, C, D, or E as an ingredient in concrete or plaster, applies equally when any other material of the same group is used in the same proportions:

Group A: Any Portland cement.

Group B: Any lime.

Group C: Any dense sand.

Group D: Any dense calcareous aggregate, including any limestone or any calcareous gravel.

Group E: Any dense siliceous aggregate, including any basalt diorite, dolerite, granite, granodiorite or trachyte.

- (b) Perlite and vermiculite: The FRL achieved with either gypsum perlite plaster or gypsum-vermiculite plaster applies equally for both plasters.

5. Columns Covered with Lightweight Construction

- (a) A column protected by lightweight construction to achieve an FRL which passes through a *building element* that is required to have an FRL or a resistance to the incipient spread of fire must be installed using a method and materials identical with a prototype assembly of the construction that has achieved the required FRL or resistance to the incipient spread of fire.
- (b) Sealing at floor level: A plug of *non-combustible* material must seal all voids at each floor level, including voids between the column and its covering if:
- a steel column extends through 2 or more *storeys*; and
 - the fire-resisting covering is not in continuous contact with the column.
- (c) Protection against injury: If the fire-resisting covering of a steel column is lightweight construction:
- the covering must be protected by metal or other suitable material if the column is liable to damage from the movement of vehicles, materials or equipment; and
 - the voids must be filled solid with *non-combustible* material to a height of not less than 1.2 m above the floor level to prevent indenting, if the covering is not in continuous contact with the column.

Table 1: Fire Resistance Levels Deemed to be Achieved by Certain Building Element

Building Element	Thickness of principle material (mm)				
	60/60/60	90/90/90	120/120/120	180/180/180	240/240/240
WALL					
Masonry					
Ashlar	-	-	-	-	300
Calcium silicate	Refer AS 3700				
Concrete	Refer AS 3700				
Fired clay (inc. terracotta)	Refer AS 3700				
Concrete					
No-fines	-	-	-	150	300
Prestressed	Refer AS 3600				
Reinforced	Refer AS 3600				
Plain	-	-	-	150	170

SECTION A -GENERAL PROVISIONS

Building Element	Thickness of principle material (mm)				
	60/60/60	90/90/90	120/120/120	180/180/180	240/240/240
Solid gypsum blocks	75	90	100	110	125
Gypsum – perlite or Gypsum vermiculite – plaster on metal lath and channel (non-loadbearing walls only)	50	50	65	-	-
CONCRETE COLUMN					
Prestressed	Refer AS 3600				
Reinforced	Refer AS 3600				
HOT-ROLLED STEEL COLUMN					
(Including a fabricated column) exposed on no more than 3 sides: Fire protection of					
Concrete – Cast in-situ – loadbearing	25	30	40	55	75
Concrete – Cast in-situ – non-loadbearing unplastered	25	30	40	50	60
Concrete – Cast in-situ – plastered 13 mm	25	25	30	40	50
Gypsum – Cast in-situ –	-	-	-	-	50
Gypsum – perlite or Gypsum-vermiculite plaster sprayed to contour	20	25	35	50	55
Gypsum – perlite or Gypsum-vermiculite plaster sprayed on metal lath	20	20	25	35	45
HOT-ROLLED STEEL COLUMN					
(Including a fabricated column) exposed on no more than 3 sides and with column spaces filled: Fire protection of					
Solid calcium-silicate masonry	50	50	50	50	65

SECTION A -GENERAL PROVISIONS

Building Element	Thickness of principle material (mm)				
	60/60/60	90/90/90	120/120/120	180/180/180	240/240/240
Solid clay masonry	50	50	50	65	90
Solid concrete masonry	50	50	50	65	90
Solid gypsum blocks	50	50	50	50	65
Hollow terracotta blocks –					
plastered 13 mm	50	50	50	65	90
HOT-ROLLED STEEL COLUMN					
(Including a fabricated column) exposed on no more than 3 sides and with column spaces unfilled : Fire protection of					
Solid calcium-silicate masonry	50	50	50	-	-
Solid clay masonry	50	50	65	-	-
Solid concrete masonry	50	50	65	-	-
Solid gypsum blocks	50	50	50	-	-
Hollow terracotta blocks –					
plastered 13 mm	50	50	65	-	-
HOT-ROLLED STEEL COLUMN					
(Including a fabricated column) exposed on 4 sides: Fire protection of					
Concrete – Cast in-situ – loadbearing	25	40	45	65	90
Concrete – Cast in-situ – non- loadbearing – unplastered	25	30	40	50	65
Concrete – Cast in-situ – plastered 13 mm	25	25	30	40	50
Gypsum – Cast in-situ –	-	-	-	-	50
Gypsum – perlite or	25	30	40	55	65

SECTION A -GENERAL PROVISIONS

Building Element	Thickness of principle material (mm)				
	60/60/60	90/90/90	120/120/120	180/180/180	240/240/240
Gypsum-vermiculite plaster sprayed to contour					
Gypsum – perlite or Gypsum-vermiculite plaster sprayed on metal lath	20	20	30	40	50
HOT-ROLLED STEEL COLUMN					
(Including. a fabricated column) exposed on 4 sides and with column spaces filled: Fire protection of					
Solid calcium-silicate masonry here	50	50	50	65	75
Solid clay masonry	50	50	50	75	100
Solid concrete masonry	50	50	50	75	100
Solid gypsum blocks	50	50	50	65	75
Hollow terracotta blocks – plastered 13 mm	50	50	50	75	100
HOT-ROLLED STEEL COLUMN					
(Including a fabricated column) exposed on 4 sides and with column spaces unfilled: Fire protection of					
Solid calcium-silicate masonry here	50	50	50	-	-
Solid clay masonry	50	50	65	-	-
Solid concrete masonry	50	50	65	-	-
Solid gypsum blocks	50	50	50	-	-
Hollow terracotta blocks – plastered 13 mm	50	50	65	-	-
BEAM					
Concrete –					
Prestressed	Refer AS 3600				

SECTION A -GENERAL PROVISIONS

Building Element	Thickness of principle material (mm)				
	60/60/60	90/90/90	120/120/120	180/180/180	240/240/240
Reinforced	Refer AS 3600				
Hot-rolled Steel (Including an open-web joist girder truss etc) exposed on no more than 3 sides: Fire protection of					
Concrete – Cast in-situ –	25	30	40	50	65
Gypsum – perlite or Gypsum- vermiculite plaster sprayed to contour	20	25	35	50	55
Gypsum – perlite or Gypsum- vermiculite plaster sprayed on metal lath	20	20	25	35	45
Hot-rolled Steel (inc. an open-web joist girder truss etc) exposed on 4 sides: Fire protection of					
Concrete – Cast in-situ –	25	40	45	60	90
Gypsum – perlite or Gypsum- vermiculite plaster sprayed to contour	25	30	40	55	65
Gypsum – perlite or Gypsum- vermiculite plaster sprayed on metal lath	20	20	30	40	50
FLOOR, ROOF OR CEILING					
Concrete –					
Prestressed	Refer AS 3600				
Reinforced	Refer AS 3600				

Annexure to Table 1

1. Scope

This Specification sets out the descriptions of elements referred to in Specification A5.3, Table 1.

2. Mortar for masonry

Masonry units of ashlar, calcium silicate, concrete or fired clay (including terracotta blocks) must be laid in cement mortar or composition mortar complying with the relevant provisions of AS 3700.

3. Gypsum blocks

Gypsum blocks must be laid in gypsum-sand mortar or lime mortar.

4. Gypsum-sand mortar and plaster

Gypsum-sand mortar and gypsum-sand plaster must consist of either:

- (a) not more than 3 parts by Part of sand to 1 part by volume of gypsum; or
- (b) if lime putty is added, not more than 2.5 parts by Part of sand to 1 part by volume of gypsum and not more than 5% of lime putty by volume of the mixed ingredients.

5. Gypsum-perlite and Gypsum-vermiculite Plaster

Gypsum-perlite or gypsum-vermiculite plaster must be applied:

- (a) in either one or 2 coats each in the proportions of 1 m³ of perlite or vermiculite to 640 kg of gypsum if the required thickness of the plaster is not more than 25 mm; and
- (b) in 2 coats if the required thickness is more than 25 mm, the first in the proportion of 1 m³ of perlite or vermiculite to 800 kg of gypsum and the second in the proportion of 1 m³ perlite or vermiculite to 530 kg of gypsum.

6. Plaster of Cement and Sand or Cement, Lime and Sand

Plaster prescribed in Table 1 must consist of:

- (a) cement and sand or cement, lime and sand; and
- (b) may be finished with gypsum, gypsum- sand, gypsum-perlite or gypsum-vermiculite plaster or with lime putty.

7. Plaster Reinforcement

If plaster used as fire protection on walls is more than 19 mm thick, it must be reinforced with:

- (a) expanded metal lathe that:
 - (i) has a mass per unit area of not less than 1.84 kg/m;
 - (ii) has not fewer than 98 meshes/m; and
 - (iii) is protected against corrosion by galvanizing or other suitable method; or
- (b) 13 mm x 13 mm x 0.710 mm galvanized steel wire mesh; and
- (c) the reinforcement must be securely fixed at a distance from the face of the wall of not less than 1/3 of the total thickness of the plaster.

8. Ashlar stone masonry

Ashlar masonry must not be used in a part of the *building* containing more than 2 storeys, and must not be of:

- aplite, granite, granodiorite, quartz dacite, quartz diorite, quartz porphyrite;
- quartz porphyry, conglomerate, quartzite or sandstone;
- chert or flint;
- limestone; or
- marble.

9. Dimensions of masonry

The thickness of concrete masonry is calculated as follows:

Solid Units

For masonry in which the amount of perforation or coring of the units does not exceed 25% by volume (based on the overall rectangular shape of the unit), the thickness of the wall must be calculated from the manufacturing dimensions of the units and the specified thickness of the joints between them as appropriate.

Hollow Units

For masonry in which the amount of perforation or coring of the units exceeds 25% by volume (based on the overall rectangular shape of the unit), the thickness of the wall must be calculated from the equipment thicknesses of the units and the specified thickness of the joints between them as appropriate.

Equivalent Thickness

The equivalent thickness of a masonry unit is calculated by dividing the net volume by the area of one vertical face.

Cavity Walls

The thickness of a cavity wall is the sum of the thicknesses of the leaves determined in accordance with 9.a and/or 9.b as appropriate.

Cavity Walls of Different Materials

If the 2 leaves of a cavity wall are of units of different type, the thickness required is that listed for the less fire-resistant material (i.e., the greater thickness).

10. Height-to-thickness ratio of certain walls

The ratio of height between lateral supports to overall thickness of a wall of ashlar, no-fines concrete, unreinforced concrete, solid gypsum blocks, gypsum-perlite or gypsum-vermiculite plaster on metal lath and channel, must not exceed:

- (a) 20 for a loadbearing wall; or
- (b) 27 for a non-loadbearing wall.

11. Slenderness ratio of masonry

Maximum Value

The slenderness ratio of a masonry wall must not exceed the appropriate value in Table AX.1.

Calculation

The slenderness ratio of a masonry wall is calculated in accordance with AS 3700. In the case of cavity walls, it is calculated for each leaf separately. Each leaf must satisfy 11.1.

Table AX.1 Maximum Slenderness Ratios for Masonry Walls

Type of unit	60/60/60	90/90/90	120/120/120
Concrete in which the basalt content of the aggregate is:			
Less than 45%	18	17	16
45% or more	22.5	21	19.5
Reinforced masonry – all types of units designed for:			
Axial forces and flexure	27	27	27
Flexure with super-imposed axial forces less than 5% of load capacity	36	36	36

12. Protection to Masonry Reinforcement

In a *building element* of reinforced masonry designed for fire-resistance, the distance from the surface of the element to the surface of the reinforcement must not be less than:

- for FRL 60/60/60 or 90/90/90 – 30 mm; and
- for FRL 120/120/120 – 40 mm.

13. Increase in Thickness by Plastering

General

The tabulated thicknesses are those of the principal material. They do not include the thickness of plaster which must be additional to the listed thickness of the material to which it is applied.

SECTION A -GENERAL PROVISIONS

Walls

If a wall of concrete masonry is plastered on both sides to an equal thickness, the thickness of the wall for the purposes of Table 1 may be increased by the following proportions of the thickness of the plaster on one side:

- For concrete masonry in which the aggregate is of a density in excess of 1,800 kg/m³: 100%;
- For concrete masonry in which the aggregate is of a density between 1,600 and 1,800 kg/m³: 85%; and
- For concrete masonry in which the aggregate is of a density less than 1,800kg/m³: 75%.

14. Concrete Slabs Beams Walls and Columns

The requirements to meet specific FRL values are those contained in AS 3600. However, for simple structures, the following procedures may be adopted.

Structural Adequacy Criterion

Table AX.2a gives the minimum dimensions for meeting specific levels of *structural adequacy* for:

Solid or Hollow-Core Plain Slabs

The clear cover to the longitudinal reinforcement or tendons. A slab is continuous if it is flexurally continuous along at least one edge under the imposed loads.

Ribbed Slabs with Ribs Spaced at not more than 1,200 mm Center to Center

The minimum width of the rib and the clear cover to the reinforcement or tendons of the ribs. The slabs spanning the ribs may be treated as plain slabs as at (a).

Beams

The upper surface of the beams must be integral with a slab or protected by one.

The minimum width of web (rectangular or uniformly tapering cross-section) and the clear cover to the reinforcement or tendons.

Solid or Hollow-Core Vertical Walls

The clear cover to the reinforcement or tendons. The effective thickness of the wall must be at least equal to that given in Table 6.3 for the FRL for the *insulation* criterion equal in period to the *required structural adequacy* criterion. In addition, the slenderness ratio must not exceed the values given in Table AX.2b.

Columns which are:

Exposed on all sides of fire; built into or form part of a wall that does not have a fire separating function; built into or form part of a wall that has a lower value of *structural adequacy* than *required* for the column; or built into and protrude by a distance in excess of the value of the clear cover to the longitudinal reinforcement:

The minimum cross-sectional dimension and the clear cover to the reinforcement.

Table AX.2a: Fire Resistance Limits – Requirements for Structural Adequacy Criterion

Building element	FRL (minutes)			
	30	60	90	120
Plain Slabs				
Simply supported one-way, clear cover (mm) to:				
Reinforcement	15	20	25	30
Tendons	20	25	35	40
Simply supported two-way, clear cover (mm) to:				
Reinforcement	15	15	20	25

SECTION A -GENERAL PROVISIONS

Building element	FRL (minutes)			
	30	60	90	120
Tendons	15	20	30	35
Continuous one-way and two-way, clear cover (mm) to:				
Reinforcement	10	15	15	15
Tendons	15	20	25	25
Ribs of plain slab min. width x clear cover (mm) x (mm)				
Simply supported one-way and two-way ribbed slabs				
Reinforcement	80x15	110x25	135x35	150x45
Tendons	80x25	110x35	135x45	150x55
Continuous one-way and two-way ribbed slabs min. width x clear cover (mm) x (mm)				
Reinforcement	70x15	75x20	110x25	125x35
Tendons	70x25	75x30	110x35	125x45
Beams min. width of web (mm) x clear cover (mm) Simply supported:				
To reinforcement	75x20	120x30 or 150x25 or 240x20	150x45 or 200x35 or 300x30 or 500x25	200x55 or 240x45 or 360x40 or 600x33
To tendon	75x25	120x35 or 150x30 or 240x25	150x55 or 200x45 or 300x40 or 500x35	200x65 or 240x55 or 360x50 or 600x43
Continuous:				
To reinforcement	75x20	120x20	150x25 or 200x20	200x35 or 240x25 or 380x20

SECTION A -GENERAL PROVISIONS

Building element	FRL (minutes)			
	30	60	90	120
To tendon	75x25	120x25	150x35 or 200x30	200x45 or 240x35 or 380x30
Vertical wall Clear cover in mm				
To reinforcement	20	20	30	40
To tendon	30	30	30	30
Note: vertical walls must also satisfy the requirements of Table 6.1b				
Columns min. cross-clear sectional x cover dimension (mm)x(mm)				
To reinforcement	150x10	200x20 or 240x15	250x35 or 300x25	300x45 or 400x35

Table AX.2b: Maximum Allowable Slenderness Ratio for Concrete Walls

Ratio of design axial force to the product of gross cross-sectional area and the characteristic compressive cylinder strength at 28 days	Corresponding maximum value of slenderness ratio (effective height/thickness)
0.0	50
0.005	35
0.03	20
0.10	15
Notes:	
<ol style="list-style-type: none"> 1. Values in between can be interpolated. 2. Design axial force = 1.1 dead load +0.6 live load including impact. 3. The characteristic compressive strength in MPa is generally expressed as the grade of the concrete. 	

Integrity Criterion

This criterion is relevant only for slabs and walls and not for ribs, beams and columns. It is satisfied if the criteria for *structural adequacy* and *insulation* are *met* for the period equal to that *required* for the *integrity* of the slab or wall as appropriate.

Insulation Criterion

This criterion is also relevant only for slabs and walls. It is met by meeting the requirement for minimum effective thickness as given in Table AX.3. The effective thickness of solid slabs and walls is the actual thickness. The effective thickness of hollow core slabs and walls is the value of the net cross-sectional area divided by the width of the cross-section. With hollow core slabs and walls, the

SECTION A -GENERAL PROVISIONS

thickness of concrete between voids and between any part of a void and the nearest surface must be not less than 25 mm or 20% of the effective thickness of the slab.

Table AX.3: Minimum Effective Thickness for Insulation

FRL for insulation criterion minute	Effective thickness mm
30	60
60	80
90	100
120	120

15. Gypsum-Perlite or Gypsum-Vermiculite Plaster on Metal Lath:

Walls

In walls fabricated of gypsum-perlite or gypsum-vermiculite plaster on metal lath and channel:

- the lath must be securely wired to each side of 19 mm x 0.44 kg/m steel channels (used as studs) spaced at not more than 400 mm centers; and
- the gypsum-perlite or gypsum-vermiculite plaster must be applied symmetrically to each exposed side of the lath.

Columns

For the fire protection of steel columns with gypsum-perlite or gypsum-vermiculite on metal lath:

- the thickness of the plaster must be measured from the back of the lath;
- the lath must be fixed at not more than 600 mm centers vertically to steel furring channels; and
 - if the plaster is to be 35 mm thick or more – at least 12 mm clear of the column;
 - if the plaster is to be less than 35 mm thick – at least 6 mm clear of the column;
 - the plaster may be applied to self-furring lath with furring dimples to hold it not less than 10 mm clear of the column.

Beams

For the fire protection of steel beams with gypsum-perlite or gypsum-vermiculite on metal lath:

- the lath must be fixed at not more than 600 mm centers to steel furring channels and at least 20 mm clear of the steel; and
- the thickness of the plaster must be measured from the back of the lath.

16. Exposure of Columns and Beams

Columns

A column incorporated in or in contact on one or more sides with a wall of solid masonry or concrete at least 100 mm thick may be considered to be exposed to fire on no more than 3 sides.

Beams

A beam, open-web joist, girder or truss in direct and continuous contact with a concrete slab or a hollow block floor or roof may be considered to be exposed to fire on no more than 3 sides.

17. Filling of Column Spaces

Steel columns are deemed to have FRLs of more than 120/-/-, the spaces between the fire-protective material and the steel (and any re-entrant parts of the column itself) must be filled solid with a fire-protective material like concrete or grout.

18. Reinforcement for Column and Beam Protection

Masonry

Concrete masonry for the protection of steel columns must have steel wire or mesh reinforcement in every second course and lapped at the corners.

Structural Concrete

If a steel column or a steel beam is to be protected with structural concrete:

- (a) the concrete must be reinforced with steel-wire mesh or steel-wire binding placed about 20 mm from its outer surface; and
- (b) for concrete less than 50 mm thick, the steel wire must be:
 - at least 3.15 mm in diameter; and
 - spaced at not more than 100 mm vertically;
- (c) or, for concrete not less than 50 mm thick, the steel wire must be either:
 - of a diameter and spacing in accordance with (b); or
 - at least 5 mm in diameter and spaced at not more than 150 mm vertically.

Gypsum-perlite or Gypsum-vermiculite Plaster Sprayed to Contour

If a steel column or steel beam is protected with either gypsum-perlite or gypsum-vermiculite plaster sprayed to contour and the construction falls within the limits of Table AX.4, the plaster must be reinforced with:

- expanded metal lath complying with Clause 1.4; or
- galvanized steel mesh complying with Clause 1.4.

The reinforcement must be placed at a distance from the face of the plaster of at least 1/3 of the thickness of the plaster and must be securely fixed to the column or beam at intervals of not more than the relevant listing in Table AX.4.

For the purposes of Table AX.4:

- “vertical” includes a surface at not more than 10° to the vertical;
- “horizontal” includes a surface at not more than 100 to the horizontal; and
- “underside” means the underside of any horizontal or non-vertical surface.

Table AX.4: Reinforcement of Gypsum-Perlite or Gypsum-Vermiculite Plaster Sprayed to Contour

Surface to be protected	Reinforcement required if smaller dimension of surface exceeds (mm)	Max spacing of fixings of the mesh to surface (mm)
Members with H or I cross-section:		
Vertical	450	450
Non-vertical	300	300
Underside	300	300
Upper side of a horizontal surface:	Not required	
Members with other shapes		
Vertical	Any size	450
Non-vertical	Any size	300
Upper side of a horizontal surface	Not required	

19. Thickness of Column and Beam Protection

The thickness of the fire-protection to steel columns and steel beams (other than fire protection of gypsum-perlite or gypsum-vermiculite plaster sprayed on metal lath or sprayed to contour) is to be measured from the face or edge of the steel, from the face of a splice plate or from the outer part of rivet or bolt, whichever is the closest to the outside of the fire-protective construction, except that:

- if the thickness of the fire-protection is 40 mm or more, rivet heads may be disregarded; and
- if the thickness of the fire-protection is 50 mm or more:
 - (i) any part of a bolt (other than a high-tensile bolt) may be disregarded; and
 - (ii) a column splice plate within 900 mm of the floor may encroach upon the fire protection by up to a 1/4 of the thickness of the fire protection.

SPECIFICATION A4.3.2

Early Fire Hazard Test for Assemblies

1. Scope

This Specification sets out the procedures for determining the Early Fire Hazard indices of components and assemblies. These tests classify building materials, their surface finishes and furnishings according to:

- their tendencies to ignite;
- their tendencies to spread flame;
- the heat they develop once ignition has occurred; and
- their tendencies to produce smoke.

2. Form of Test

This Specification sets out the procedures for determining the Early Fire Hazard indices of components and assemblies.

Tests must be carried out in accordance with the following:

- for the determination of the Spread-of-Flame Index and Smoke-Developed Index — AS/NZS 1530.3; and
- for the determination of the ability to prevent ignition and to screen its core material from free air — AS 1530.4.

3. Test Specimens

Test specimens must incorporate:

- all types of joints; and
- all types of perforations, recesses or the like for pipes, light switches or other fittings, which are proposed to be used for the member or assembly of members in the *building*.

4. Concession

Clause 3 does not apply to joints, perforations, recesses or the like that are larger than those in the proposed application and have already been tested in the particular form of construction concerned and found to comply with the conditions of test.

5. Smaller Specimens Permitted

A testing laboratory may carry out the test at pilot scale if a specimen (which must be not less than 900 mm) will adequately represent the proposed construction in the *building*, but the results of that test do not apply to construction larger than limits defined by the laboratory conducting the pilot examination.

Section

B



STRUCTURE

THIS SECTION APPLIES TO ALL BUILDINGS
(CLASS 1 to CLASS 10)

SECTION B -STRUCTURE

Contents

PERFORMANCE REQUIREMENTS	1
OBJECTIVES	1
BP1 Structure.....	1
BP2 Demolition	1
BP3 Foundations and Ground Conditions.....	1
BP4 Durability	1
REQUIRED PERFORMANCE	1
BP1 Structure	1
BP1.1 General Requirements.....	1
BP1.2 Physical Conditions / Loads	2
BP1.3 Design and Construction Requirements	2
BP1.4 Sitework and Excavation	3
BP1.5 Buildings in Flood Areas	3
BP1.6 Human Impact Against Glazing	3
BP2 Demolition	3
BP3 Foundations and Ground Conditions	4
BP4 Durability	4
DEEMED-TO-SATISFY PROVISIONS	5
B1 STRUCTURE.....	5
B1.1 General Requirements – Structure.....	5
B1.2 Resistance to Actions	5
B1.3 Determination of Individual Actions.....	5
B1.4 Structural Resistance of Materials and Forms of Construction	8
B1.5 Excavations	9
B1.6 Construction of Buildings in Flood Hazard Areas.....	9
B1.7 Human Impact Against Glazing	9
B2 Demolition	12
B2.1 General Requirements	12
B2.2 Applicable Standard	12
B2.3 Dangerous Buildings	12
B2.4 Buildings Containing Asbestos	13
B3 Foundation and Ground Conditions.....	13
B3.1 General Requirements	13
B3.2 Sloping Ground.....	13

SECTION B -STRUCTURE

B3.3 Foundation Design..... 13

B3.4 Water Table Rise Due to Climate Change..... 14

B3.5 Other Geotechnical Hazards 14

B4 Durability 14

B4.1 General Requirements 14

B4.2 Corrosivity Classification 14

B4.3 Electrical..... 14

B4.4 Mechanical Equipment and Air Conditioners 14

B4.5 Window Frames..... 15

B4.6 Water Storage Tanks 15

B4.7 Wall Paint Systems 15

PERFORMANCE REQUIREMENTS

OBJECTIVES

BP1 Structure

The Objective of this Section is to:

- (a) safeguard people from injury caused by structural failure;
- (b) safeguard people from loss of *amenity* caused by structural behaviour;
- (c) protect other property from physical damage caused by structural failure;
- (d) safeguard people and property from flood hazards; and
- (e) avoid undue risk of injury to people when glazing is installed in a *building*.

BP2 Demolition

The Objective of this Section is to:

- (a) safeguard people from injury caused by demolition; and
- (b) protect other property from physical damage caused by demolition.

BP3 Foundations and Ground Conditions

The Objective of this Section is to:

- (a) safeguard people from injury caused by foundation and ground failure;
- (b) safeguard people from loss of amenity caused by foundation and ground behaviour; and
- (c) protect other property from physical damage caused by foundation failure.

BP4 Durability

The Objective of this Section is to:

- (a) ensure that a *building* will throughout its *design life* continue to satisfy the other objectives of the VNBC.
- (b) building materials, components and construction methods shall be sufficiently durable to ensure that the *building*, without reconstruction or major renovation, satisfies the other functional statements in the VNBC throughout the *design life* of the *building*.

REQUIRED PERFORMANCE

BP1 Structure

BP1.1 General Requirements

- (a) *Buildings, building elements*, and sitework shall have a low probability of rupturing, becoming unstable, losing equilibrium, or collapsing during construction or *alteration* and throughout their lives.
- (b) *Buildings, building elements*, and sitework shall have a low probability of causing loss of *amenity* through undue deformation, vibratory response, degradation, or other physical characteristics throughout their lives, or during construction or *alteration* when the *building* is in use.

BP1.2 Physical Conditions / Loads

Account shall be taken of all physical conditions likely to affect the stability of *building, building elements* and sitework, during the intended *design life* of the *building* including:

- (a) self-weight;
- (b) imposed gravity loads arising from use;
- (c) temperature;
- (d) earth pressure;
- (e) water and other liquids;
- (f) wind;
- (g) fire;
- (h) impact;
- (i) explosion;
- (j) reversing and fluctuating effects;
- (k) differential movement;
- (l) ground movement caused by swelling; shrinkage; landslip or subsidence; and site works
- (m) construction activity;
- (n) termites;
- (o) vegetation;
- (p) adverse effects due to insufficient separation from other *buildings*;
- (q) influence of equipment; services; non-structural elements and contents;
- (r) time dependent effects including creep and shrinkage; and
- (s) effects on physical conditions and loads due to climate change.

BP1.3 Design and Construction Requirements

Due allowance shall be made for:

- (a) the consequence of failure;
- (b) the intended use of the building;
- (c) effects of uncertainties resulting from construction activities, or the sequence in which construction activities occur;
- (d) the quality of workmanship available;
- (e) the quality of materials available;
- (f) the availability of appropriate construction equipment;
- (g) variation in the properties of materials and the characteristics of the site;
- (h) changes in the characteristics of the site due to climate change;
- (i) corrosion and durability; and
- (j) accuracy limitations inherent in the methods used to predict the stability of *buildings*.

The design of *buildings* must satisfy:

- (a) During the *design life* of the *building* the probability of experiencing unacceptable deflections or vibrations must not exceed 5%;
- (b) The probability of structural failure must not be exceeded those listed in Table BP1.3. within the *design life* of the *building*.

Table BP1.3: Probability of Failure

Importance Level	Annual Probability of Failure	Probability of Failure over a 50-year design life
IL1	0.004%	0.2%
IL2	0.002%	0.1%
IL3	0.001%	0.05%
IL4	0.0005%	0.025%

BP1.4 Sitework and Excavation

- (a) Sitework, where necessary, shall be carried out to:
 - 1. provide stability for construction on the site; and
 - 2. avoid the likelihood of damage to other property.
- (b) Any sitework and associated supports shall take account of the effects of:
 - 1. changes in ground water level;
 - 2. water, weather and vegetation; and
 - 3. ground loss and slumping.
- (c) Any excavation shall be carried out to:
 - 1. ensure the stability of the excavation from collapse; and
 - 2. avoid the likelihood of damage to other property.

BP1.5 Buildings in Flood Areas

- (a) A *building* in a *flood hazard area*, must be designed and constructed, to the degree necessary, to the *design flood level (DFL)* throughout its design working life, inclusive of climate change:
 - 1. to resist flotation, collapse or significant permanent movement resulting from action of hydrostatic, hydrodynamic, erosion and scour, wind and other actions during the *design flood event* (integrating sea level rise and climate change) throughout its design working life considering *flood* height and maximum flow velocity; and
 - 2. to safeguard occupants and other people against illness and injury caused by *flood* water affecting the *building*.
- (b) The actions and requirements to be considered to satisfy (a) include but are not limited to:
 - 1. flood actions;
 - 2. elevation requirements;
 - 3. foundation and footing requirements;
 - 4. requirements for enclosures below the *flood hazard level*;
 - 5. requirements for structural connections;
 - 6. material requirements;
 - 7. requirements for utilities;
 - 8. requirements for occupant egress; and
 - 9. requirements for mould, mildew, and corrosion.
- (c) Utilities and supporting infrastructure associated with a *building* must be designed to reduce the effects of *flood* water on utilities and supporting infrastructure in the event of a *flood* up to the *Design Flood Level (DFL)*.
- (d) Sanitation systems and sanitary drains must be protected from backflow so that in the event of a *flood* up to the *Design Flood Level (DFL)* the effects of flood water on the *building* are reduced.
- (e) Electrical and Mechanical systems must be designed and located so that their ability to function effectively is not affected by a *flood* event up to the *Design Flood Level (DFL)*.
- (f) Water storage and collection systems must be designed and located so that their ability to function effectively is not affected by a *flood* event up to the *Design Flood Level (DFL)*.

BP1.6 Human Impact Against Glazing

Glass installations that are at risk of being subjected to human impact must have glazing that:

- (a) if broken on impact, will break in a way that is not likely to cause injury to people; and
- (b) resists a reasonably foreseeable human impact without breaking; and
- (c) is protected or marked in a way that will reduce the likelihood of human impact.

BP2 Demolition

The demolition of *buildings* shall be carried out:

- (a) in a way that avoids the likelihood of premature collapse;
- (b) in a planned and controlled manner;
- (c) in a way that minimizes dust, vibrations, noise, water, fire, smoke and fumes;
- (d) in a way that identifies hazardous materials and appropriately removes them; and
- (e) using means and methods to prevent damage to utilities, roads, and adjacent properties.

BP3 Foundations and Ground Conditions

Foundations shall be designed, and ground conditions verified to prevent *building* damage, partial or total *building* collapse, and unacceptable *building* movements during its *design life*; and including current and future conditions/behaviour of the ground and water levels.

BP4 Durability

Durability of *building elements*, building system components, and elements embedded in concrete shall be selected and/or protected to satisfy the required performance listed in Table BP4.

Table BP4: Required Performance – Durability

Durability of Building Elements
<p>(1) <i>Building elements</i> must, with only normal maintenance, continue to satisfy the <i>Performance Requirements</i> of this code for the lesser of the specified intended life of the building, if stated, or:</p> <ul style="list-style-type: none"> a. the life of the <i>building</i>, being not less than 50 years, if: <ul style="list-style-type: none"> i. those <i>building elements</i> (including floors, walls, and fixings) provide structural stability to the <i>building</i>; or ii. those <i>building elements</i> are difficult to access or replace; or iii. failure of those <i>building elements</i> to comply with the building code would go undetected during both normal use and maintenance of the <i>building</i>. <p>(2) 15 years if:</p> <ul style="list-style-type: none"> a. those <i>building elements</i> (including the building envelope, exposed plumbing in the subfloor space, and in-built chimneys and flues) are moderately difficult to access or replace; or b. failure of those <i>building elements</i> to comply with the building code would go undetected during normal use of the <i>building</i> but would be easily detected during normal maintenance. <p>(3) 5 years if:</p> <ul style="list-style-type: none"> a. the <i>building elements</i> (including services, linings, renewable protective coatings, and fixtures) are easy to access and replace; and b. failure of those <i>building elements</i> to comply with the building code would be easily detected during normal use of the <i>building</i>.
Durability of Building System Components
<p>(1) Individual <i>building elements</i> which are components of a building system and are difficult to access or replace must either:</p> <ul style="list-style-type: none"> a. all have the same durability; or b. be installed in a manner that permits the replacement of <i>building elements</i> of lesser durability without removing <i>building elements</i> that have greater durability and are not specifically designed for removal and replacement.
Durability of Element Embedded in Concrete
<p>(1) Steel reinforcement and metallic elements embedded in concrete shall have a low rate of corrosion and shall not damage nor compromise the strength and stability of the concrete element during the intended life of the building.</p>

DEEMED-TO-SATISFY PROVISIONS

B1 STRUCTURE

B1.1 General Requirements – Structure

- (a) *Deemed-to-Satisfy Solutions* presented below satisfy the *Performance Requirements*;
- (b) Where a *Performance Solution* is proposed, the relevant *Performance Requirements* must be determined in accordance with Part A2.

B1.2 Resistance to Actions

The resistance of a *building* or structure must be greater than the most critical action effect resulting from the different combinations of actions where:

- (a) The most critical action effect on a *building* or structure is determined in accordance with B1.3 and the general design procedures contained in AS/NZS 1170.0; and
- (b) The resistance of a *building* or structure is determined in accordance with B1.4.

B1.3 Determination of Individual Actions

The magnitude of individual actions must be determined in accordance with the following:

- (a) General Principles: AS/NZS 1170.0
- (b) Permanent, Imposed, and Other Actions: AS/NZS 1170.1
- (c) Wind Actions: as per Table B1.3.1

Table B1.3.1: Wind Actions, Vanuatu

Importance Level	Standard
1, 2, and 3	<p>AS 1170.2:1989 (SAA Loading Code). Use a limit state basic wind speed of 70 m/s to all areas of Vanuatu. The equivalent basic wind speed for permissible stress methods of design is 57 m/s. When the simplified procedure of AS 1170.2:1989 is followed, the value of the factor B1, to be applied is 2.3. The maps of Australia in the Standard are to be disregarded.</p> <p>Wind actions and windborne debris impact on cladding, doors, windows, vents, garage doors, and protective systems (cyclone shutters/doors) shall be per AS/NZS 1170.2.</p>
4	<p>AS/NZS 1170.2: 2021 Structural Design Actions, Part 2: Wind Actions. Use Table 3.1(A) with Cyclonic Region D (maximum) for all areas of Vanuatu. Use Table 3.3 Climate Change Multiplier (Mc) for Cyclone Region D of $Mc = 1.05$. The maps and tables of New Zealand, and the maps of Australia, are to be disregarded.</p> <p>Wind actions and windborne debris impact on cladding, doors, windows, vents, garage doors, and protective systems (cyclone shutters/doors) shall be per AS/NZS 1170.2.</p>

- (c) Earthquake Actions: as per Table B1.3.2

Table B1.3.2: Earthquake Actions, Vanuatu

Importance Level	Standard & Factors
1, 2, and 3	<p>NZS 4203:1992 Code of practice for general structural design and design loadings for buildings (Loadings Standard) Part 1, 2, and 4</p> <p>The earthquake zones for Vanuatu are marked in Figure B1.3.1, which shall be used with the NZS 4203 Standard.</p> <p>The Zone Factors corresponding to the zone numbers given in the figure shall be as follows: Zone No 7 use a Zone Factor = 0.7 Zone No 8 use a Zone Factor = 0.8</p> <p>Each zone factor applies uniformly over the whole area of the zone.</p> <p>The maps and tables specific to New Zealand shown in the NZS 4203 standard are to be disregarded.</p>
4	<p>NZS 1170.5:2004 Structural design actions – Part 5: Earthquake actions – New Zealand.</p> <p>The earthquake zones for Vanuatu are marked in Figure B1.3.1, which shall be used with the NZS 1170.5:2004 Standard.</p> <p>The Hazard factor, Z, corresponding to the zone numbers given in the figure shall be as follows: Zone No 7 use a Hazard Factor, Z = 0.7 Zone No 8 use a Hazard Factor, Z = 0.8</p> <p>Each zone factor applies uniformly over the whole area of the zone and shall be considered as the 1/500 annual probability of occurrence.</p> <p>A site-specific hazard study shall not go below the equivalent lateral force or spectra developed using the minimum Hazard Factor, Z_{min}, of not less than 0.7.</p> <p>Replace NZS 1170.5:2004 Section 3.1.6.2 with the following: For Annual probability of exceedance $< 1/250$, $N(T,D)$ shall equal $N_{max}(T)$ regardless of fault distance for the Vanuatu unless a site-specific hazard study has been submitted and approved by the <i>Approval Authority</i>. $N_{max}(T)$ = the maximum near-fault factor and is linearly interpolated for period T from Table 3.7.</p> <p>Replace definition of R in Section 3.1.1 of NZS 1170.5:2004 with: R = the return period factor R_s or R_u for the appropriate limit state determined from Clause 3.1.5 but limited such that ZR_u does not exceed 1.44; unless a site-specific hazard study has been submitted and approved by the Approval Authority that provides evidence that a lower ZR_u lower can be used.</p> <p>The maps and tables specific to New Zealand locations shown in the NZS 1170.5:2004 standard are to be disregarded.</p>

Figure B1.3.1: Earthquake Zone Map, Vanuatu

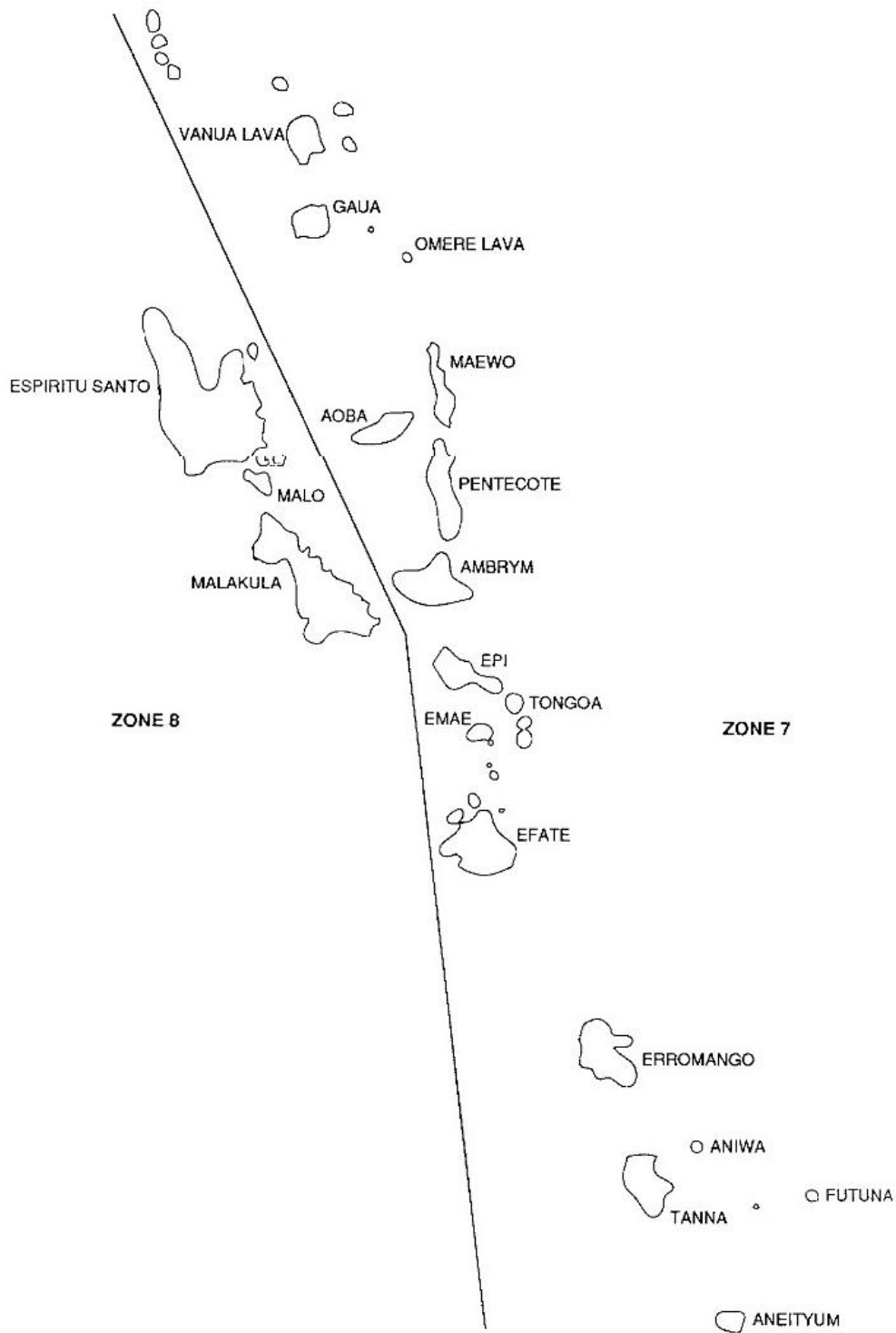

SECTION B -STRUCTURE

- (d) Ashfall Action: AS/NZS 1170.1, using the estimated weight of dry and rain-on-ash weight.
- (e) Hydrostatic and Hydrodynamic Actions, such as Coastal *flood*, storm surge, wave, riverine, and tsunami actions: AS/NZS 1170.1 and/or ASCE 7. Designs shall be designed for the worst-case action of present day and during its design life; that includes climate change for the median high emissions (SSP3-7.0) scenario, including sea-level rise, subsidence, and increased/decreased rainfall, and coastal changes that may impact wave behaviour. Actions shall also consider waterborne debris action.
- (f) Actions not covered above shall utilize AS/NZS 1170.1, other AS/NZS standards approved by the local authority, and/or the principles of structural mechanics.

B1.4 Structural Resistance of Materials and Forms of Construction

The structural resistance of materials and forms of construction must be determined in accordance with the following, as appropriate, and using Actions as determined per Part B1.3:

- (a) Masonry: NZS 4210 / NZS 4229 / NZS 4230
- (b) Concrete:
 - 1. Concrete Construction: NZS 3101 / NZS 3109 / NZS 3124
 - 2. Post-installed and cast-in fastenings: AS 5216
 - 3. Residential slabs and footings: AS 2870
- (c) Steel construction:
 - 1. Steel Structures: NZS 3404
 - 2. Cold-formed steel structures: AS/NZS 4600
 - 3. Residential and low-rise steel framing: NASH Standard – Residential and Low-Rise Steel Framing Part 1 or Part 2
- (d) Composite steel and concrete structures: AS/NZS 2327
- (e) Aluminum construction: AS/NZS 1664.1 or AS/NZS 1664.2
- (f) Timber construction:
 - 1. Timber properties: Vanuatu Timber Properties Handbook, 24 Commercial Species dated June 1998 used in conjunction with AS 2082-1979
 - 2. Design of timber structures: AS 1720.1
 - 3. Timber-framed construction (Class 1 and Class 10 only): Design using both AS 1684.3 (using Cyclonic Wind Classification C3) and NZS 3604 (using Exposure Zone D and Earthquake Zone 4). Do not use NZS 3604 for wind.
 - 4. Nail plated timber roof trusses: AS 1720.5
 - 5. Plywood: AS/NZS 2904, AS/NZS 2269
- (g) Piling: AS 2159
- (h) Glazing construction for wind actions, windborne debris impact, and rain penetration
 - 1. Glazed assemblies: AS 2047 and AS 1288
 - 2. Glazing Standards: NZS 4223
- (i) Termite Risk Management: AS 3660
- (j) Roof Construction:
 - 1. Terracotta: AS 4597
 - 2. Roof Tiling: AS 2050
 - 3. Metal Roofing: AS 1562.1
- (k) External Wall Cladding, Doors, Rolling/Garage Doors & Impact Protective Systems over windows and doors (Cyclone Shutters): shall demonstrate through testing that it can prevent penetration and entry of windborne debris as per AS/NZS 1170.2 or ASTM E1996 “basic protection.” Importance Level 4 structures shall use criteria of AS/NZS 1170.2 or ASTM E1996 “enhanced protection.”
- (l) Garage doors and other large access doors in openings not more than 3 m in height in external walls of buildings: AS/NZS 4505
- (m) Flood Resistant construction: ASCE 24, Australian Building Codes Board Standard for Construction of Buildings in Flood Hazard Areas dated 2012.3.

B1.5 Excavations

The following criteria for all excavations must be satisfied.

- (a) Excavations greater than 1.5m deep must be either:
 - 1. battered back with a slope no greater than 45° on all sides; or
 - 2. designed and certified by a *professional consultant*.
- (b) Excavations must be set back a minimum of 1.5 m from any property boundary and batter away from the boundary with a slope of no greater than 45° unless specific permission is granted by the local authority.

B1.6 Construction of Buildings in Flood Hazard Areas

- (a) Importance Level 4 buildings shall not be constructed in *flood hazard areas* (present and future SSP3-7.0 projection for the design life).
- (b) The following *buildings* are required to undertake site-specific *flood* investigations and provide suitable evidence to the satisfaction of the *Approval Authority* that *flood* hazards are adequately addressed:
 - 1. all *buildings* located within 25 m of the coastline (as measured from the mean high-water mark);
 - 2. all *buildings* where the ground surface is less than 5m elevation from the mean high-water mark;
 - 3. all *buildings* of importance level 3, 4, and 5; or
 - 4. any *building* or site that is known or historically flood with a depth greater than 300 mm; or
 - 5. any *building* that the *Approval Authority* deems to be of special or high risk.
- (c) The site-specific *flood* hazard information to be provided to the *Approval Authority* shall include as a minimum, the selection of finished floor levels and hydrostatic/hydrodynamic/wave actions based on an analysis that:
 - 1. uses a minimum design *flood* event (DFE) of 1 in 100-year average recurrence interval *flood* event and allowance for sea-level rise and/or rainfall intensity based on the IPCC scenario SSP3-7.0 for the design life of the building or other time period to the satisfaction of the *Approval Authority*; and
 - 2. uses the maximum recorded/historical *flood*, as the DFE, with record length of not less than 100 years; and
 - 3. accounts for the importance level for the building.
- (d) The minimum finished floor level of any building shall be above the *flood hazard level* (FHL), which shall not be less than the *design flood level* (DFL) for the DFE of 1 in 100-year average recurrence interval flood event, plus the freeboard (300 mm minimum for IL2, 600 mm minimum for IL3 and IL4), plus the sea-level rise for a median high emissions (SSP3-7.0) projection to the year of the design working life. The DFL shall include the wave height. If the structure is open below, the bottom of the structural element shall be higher than the FHL.
- (e) Utilities, sanitation systems, electrical systems, and water storage shall be so designed and located above the *FHL* and/or have design features that resist the effects of *flood* as per the construction standards listed in B1.4.
- (f) The *Approval Authority* can require minimum finished floor levels higher than those determined through this Part.

B1.7 Human Impact Against Glazing

- (a) Glazing of *windows* and other openings and their support systems designed only against wind loads are not safe against human impact. In order to provide for reasonable safety against injury or death resulting from glass breakage and possible falls, glazing and its support framing must be designed for the levels of risk shown in Table B1.7.1. The impact energy that the glass and its

SECTION B -STRUCTURE

framing must resist for different levels of risk and for different configurations of glazing are given in Figure B1.7.1.

- (b) The following must be taken into account while designing glazing against human impact:
1. Laminated glass and toughened glass are considered to be safety glass in terms of injury potential from fragments and splinters. Wired glass and heat-strengthened glass are not safety glasses.
 2. Annealed or laminated glass which has minor abrasion damage or has been sand blasted on the tension face has its impact strength severely reduced.
 3. The strength of glass can be substantially reduced by the lapse of time.
- (c) The barrier protection shown in Figure B1.7.1 must be designed to AS/NZS 1170.1. The deflection of the barrier must not exceed 50% of the distance between the handrail and the glass when a concentrated force of 1.2 kN is applied to the face of the barrier.

Table B1.7.1: Risk Level for Class of Building for Assessment of Required Strength of Glazing

HEIGHT OF FALL IN CASE OF GLAZING FAILURE	RISK		
	HIGH	MEDIUM	LOW
More than 6 m	2, 6, 9b	3, 4, 5, 7, 8, 9a	-
3 m to 6 m	-	2, 6, 9b	3, 4, 5, 7, 8, 9a
Up to and including 3 m	-	6, 9b	2, 3, 4, 5, 7, 8, 9a

FIGURE B1.7.1: Capacity Required of Glazing Elements Against Human Impact

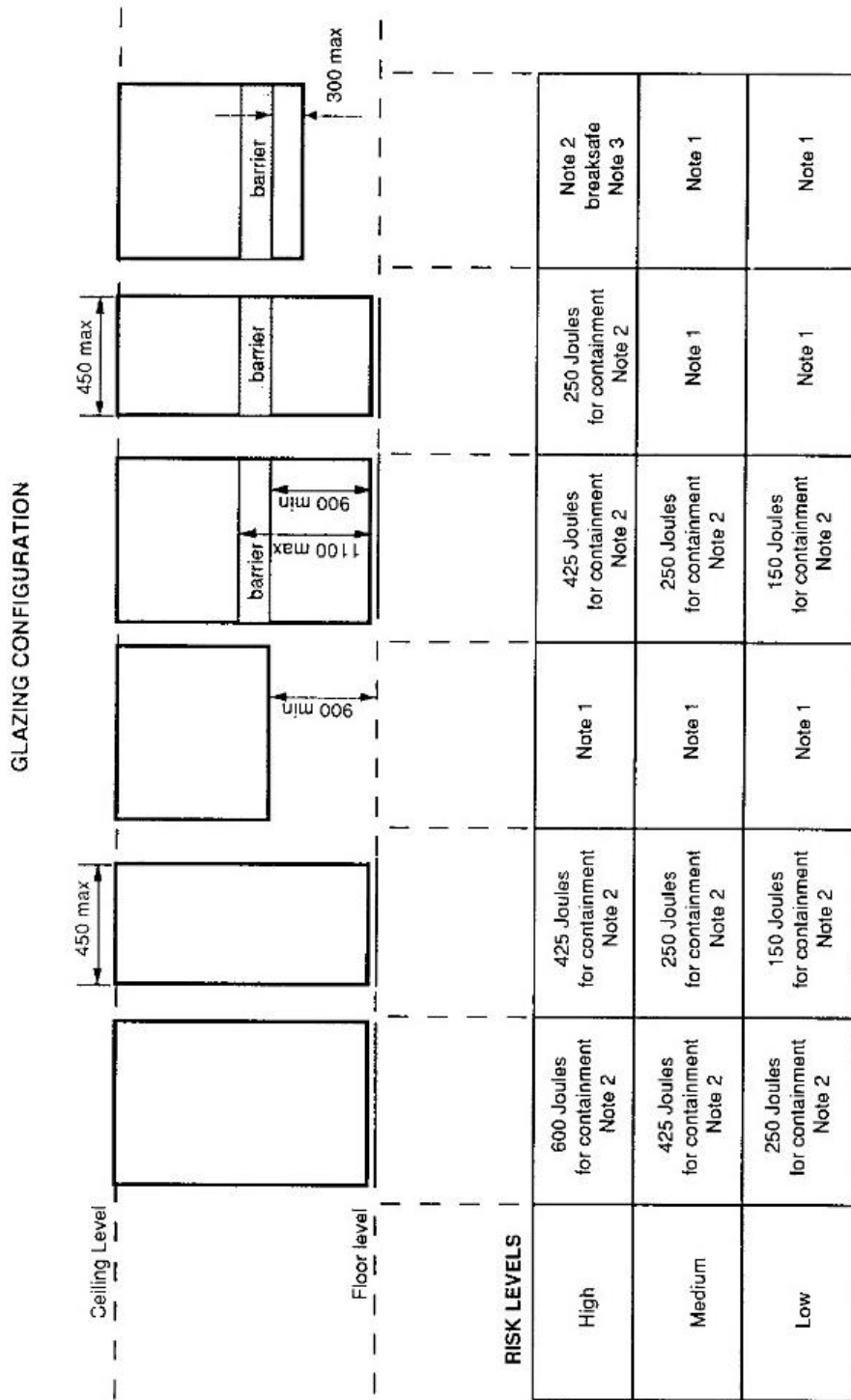

- Notes:
- 1) No specific impact requirement. Select glass as per NZS 4223.
 - 2) Containment - fracture of glass gives no significant penetration eg. laminated glass. Containment required for impacts up to and including level set.
 - 3) Breaksafe - fracture of glass gives either relatively harmless pieces or insufficient penetration to cause injury eg. laminated or toughened glass.

CAPACITY REQUIRED OF GLAZING ELEMENTS AGAINST HUMAN IMPACT

B2 Demolition

B2.1 General Requirements

All dangerous *buildings* as detailed in B2.3 or hazard prone *buildings* as detailed in B2.4 must either be stabilized, restored to *required* standards or be demolished.

The planning and execution of demolition of existing *buildings*, regardless of whether they are considered dangerous, must:

- (a) not put at risk the safety and health of the public and of the workers;
- (b) avoid damage to other properties;
- (c) avoid nuisance to others;
- (d) allow continued access to other properties; and
- (e) prevent damage to public services / roads and allow continued operation of such services / roads.

B2.2 Applicable Standard

The *Performance Requirements* for demolition of *buildings* are satisfied if demolition is planned and carried out in accordance with AS 2601.

B2.3 Dangerous Buildings

Any *building* which has any of the conditions or defects described below must be deemed to be a dangerous *building* if such conditions or defects exist to the extent that the life, health, safety or property of the public or its occupants are endangered whenever:

- (a) any required exit is not of sufficient width or size or is not so arranged as to provide safe and adequate means of egress in case of fire or other emergency;
- (b) the stress in any materials or member due to all applicable loads, is more than 1.5 times the working stress or stresses allowed for new *buildings* of similar class and type of construction;
- (c) any portion of the *building* has been damaged by fire, earthquake, wind, *flood* or by any other cause, to such an extent that its structural strength or stability is materially less than it was before such catastrophe and is less by 33% or more than the minimum requirements for new *buildings* of similar class and type of construction;
- (d) any portion or member or attachment of the *building* is likely to fail, or to become detached or dislodged, or to collapse and thereby injure persons or damage property;
- (e) any portion of the *building* has suffered distortion, cracking or settlement to such an extent that walls or other structural portions have materially less resistance to winds or earthquakes than is required in the case of similar new construction;
- (f) the *building* or any portion of it is likely to collapse or fail to perform the intended function, as a result of:
 1. dilapidation, deterioration or decay;
 2. faulty construction;
 3. the removal, movement or instability of any portion of the ground necessary for the purpose of supporting such *building*;
 4. the deterioration, decay or inadequacy of its foundation; or
 5. any other cause;
- (g) the *building*, exclusive of the foundation, shows 33% or more damage or deterioration of any supporting member or 50% damage or deterioration of its non-supporting members;
- (h) any *building* has in any non-supporting part, member or portion less than 50%, or in any supporting part, member or portion less than 66% of the:
 1. strength; or
 2. fire-resisting requirements; and
- (i) a *building* because of inadequate maintenance, dilapidation, decay, damage, faulty construction or arrangement, inadequate light, air or sanitation facilities, or otherwise, is likely to cause sickness or disease.

B2.4 Buildings Containing Asbestos

If a building is to be demolished or partially demolished, asbestos shall be removed and disposed of in accordance with the requirements of Part A9.3.

Removal or disturbance of asbestos or asbestos-containing materials during refurbishment or maintenance of building components, parts, or equipment shall be removed and disposed of in accordance with the requirements of Part A9.3.

B3 Foundation and Ground Conditions

B3.1 General Requirements

Building foundations must be designed to transfer the loads derived from Part B1 to the ground.

The *building* foundations elements must be designed in accordance with the appropriate materials Standards, as given in Part B1.4.

The ground upon which the foundations are bearing shall be good ground. Good ground is defined as:

1. Solid ground away from areas of swamp or ground likely to settle significantly when loaded; and
2. Any soil or rock capable of permanently withstanding a minimum ultimate bearing capacity of 300 kPa (i.e., an allowable pressure of 100 kPa using a safety factor of 3.0).

Where the *site* is not founded on good ground, geotechnical advice shall be sought from a suitable qualified geotechnical engineer (*Professional Consultant*) for the design of foundation systems.

B3.2 Sloping Ground

Where a *building* is to be constructed on sloping ground, due consideration shall be given to the stability of the ground under loading from the structure. The verticality of foundation elements shall be maintained, and the slope shall be battered and benched as *required*. Refer to Part B1.5 for excavation limitations including depth and batter requirements.

If the ground is sloped at greater than 30° from the horizontal, advice shall be sought from a suitable qualified geotechnical engineer (*Professional Consultant*) prior to the design and installation of any foundation element.

The potential for landslide and land slip often extends beyond the land immediately under the *building*. Where the adjacent land is sloped at greater than 30° from the horizontal in any location within 10 m of the proposed foundations of the *building*, advice shall be sought from a suitable qualified geotechnical engineer (*Professional Consultant*) prior to the design and installation of any foundation element.

B3.3 Foundation Design

For simple *buildings*: the adequacy of foundations shall be assessed on the basis of well-established and relevant local knowledge and experience of foundation conditions in the vicinity of the proposed *building*.

For timber framed houses and small *buildings*: substructure materials and forms of construction will be satisfied if they comply with NZ3604.

For complex and multi-storey *buildings* and public *buildings* of importance factor > 1: mandatory geotechnical investigation and geotechnical tests must be undertaken to determine the foundation systems as noted under clause B3.1.

Liquefaction potential shall be evaluated, identified, settlements/upheave estimated, and mitigation measures and/or appropriate foundation selection proposed as part of the geotechnical investigation and tests. Consult Vanuatu Meteorology and Geohazards Department.

B3.4 Water Table Rise Due to Climate Change

The existing water table depth, projections of future water table depth due to climate change/sea level rise and other factors, and the current and future salinity of the water shall be determined. The adequacy of foundations shall be assessed, and investigations performed as required to determine if the ultimate and allowable bearing capacity will change over time, if heave/buoyancy will occur, and if there are any soil corrosivity conditions that will trigger durability requirements of the material standards during the design working life of the *building* or structure. The median high emissions (SSP3-7.0) projection to the year of the design working life shall be the climate change scenario to verify.

B3.5 Other Geotechnical Hazards

Construction Near Active Faults – Complex and multi-storey *buildings* and public *buildings* of importance factor > 1 shall not be constructed within 20 m perpendicular to an active fault trace whether known or inferred. Consult the Vanuatu Meteorology and Geohazards Department for fault trace information, mapping, and to obtain necessary development permissions. Advice shall be sought from a suitable qualified geotechnical engineer (*Professional Consultant*).

Construction Near Landslides, Land Mass Movements, Cliff Collapse, Boulder Roll Areas, and Sinkholes/Caves/Voids – Complex and multi-storey *buildings* and public *buildings* of importance factor > 1 shall not be constructed within hazardous geotechnical areas known or inferred, unless specific studies and mitigation measures are in place. Consult the Vanuatu Meteorology and Geohazards Department for information, mapping, and to obtain necessary development permissions. Advice shall be sought from a suitable qualified geotechnical engineer (*Professional Consultant*).

B4 Durability

B4.1 General Requirements

1. *Deemed-to-Satisfy Solutions* presented below satisfy the *Performance Requirements* for Durability.
2. Where a *Performance Solution* is proposed, the relevant *Performance Requirements* must be determined in accordance with Part A2.

B4.2 Corrosivity Classification

The selection and specification of appropriate materials and protective measures shall be determined based on the definitions and requirements for determining corrosivity, based on location and construction methods, of the following standards. The more rigorous requirements of these standards and other referenced standards shall be used:

- (a) ISO 9223 Environmental Severity Classification
- (b) AS/NZS 2728
- (c) AS/NZS 2312.1
- (d) AS/NZS 2312.2
- (e) NZS 3604
- (f) New Zealand Building Code E2/AS1

B4.3 Electrical

1. All electrical conduit and junction boxes shall be non-metallic.
2. All electrical enclosures whether interior or exterior shall be corrosion, waterproof, and UV-resistant using either coated aluminium or plastic.

B4.4 Mechanical Equipment and Air Conditioners

1. Mechanical Equipment and HVAC units in Importance Level 4 *buildings* shall coat their coils and fan blades using an epoxy coating system approved by the *Approval Authority* prior to placing in operation and during routine maintenance.

2. All exteriorly located mechanical equipment, pumps, and pipes shall be appropriately located, protected, and/or have the appropriate material specifications for its *design life* considering its environmental exposure and corrosivity as per the standards in B4.2.

B4.5 Window Frames

1. All metallic window frames and components shall be anodized aluminium.
2. All window frames shall be connected to wall framing with anchors and materials that with the appropriate material specifications for its *design life* considering its environmental exposure and corrosivity as per the standards in B4.2.

B4.6 Water Storage Tanks

All water storage tanks and associated piping shall be UV-resistant.

B4.7 Wall Paint Systems

All interior and exterior surfaces shall be painted with a mould-, mildew-, and UV-resistant paint system that has low toxicity and low volatile organic compounds in compliance with national environmental legislation.

PART

2

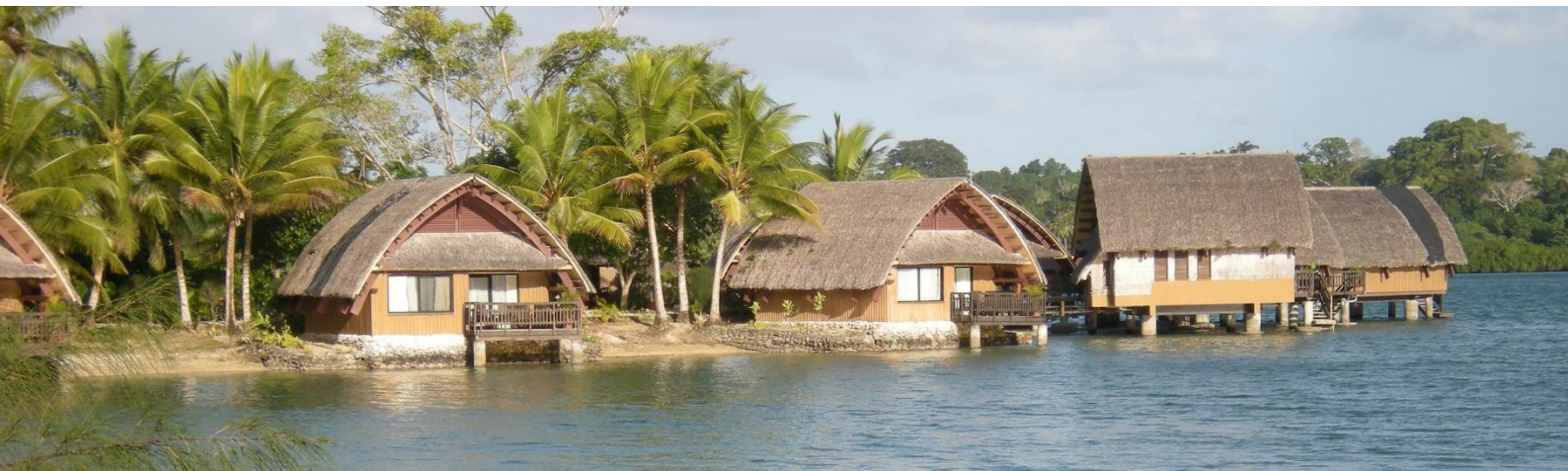

**DWELLINGS AND
OUTBUILDINGS
(CLASS 1 & CLASS 10)**

Section

DC



FIRE RESISTANCE

**THIS SECTION APPLIES DWELLINGS AND
OUTBUILDINGS (CLASS 1 & CLASS 10)**

SECTION DC – FIRE RESISTANCE

Contents

PERFORMANCE REQUIREMENTS	1
OBJECTIVES	1
REQUIRED PERFORMANCE	1
DEEMED-TO-SATIFY PROVISIONS	2
DC1 Fire Resistance and Stability	2
DC1.1 External walls of Class 1 buildings	2
DC1.2 Class 1 Buildings: Construction of external walls.	2
DC1.3 Class 10a buildings: External walls	2
DC1.4 Allowable encroachments.....	2
DC1.5 Exceptions.....	2
DC1.6 Common walls.....	2
DC1.7 Separating floors.....	3
DC1.8 Sarking-type materials	3

PERFORMANCE REQUIREMENTS

OBJECTIVES

DCP1 A Class 1 or Class 10 *building* must be so designed and constructed that the following objectives are fulfilled:

- (a) it is protected from fire in any other *building*; and
- (b) materials used in the construction be such that, if there is a fire in the *building*:
 1. the spread of fire and the generation of smoke and toxic gases will be minimized;
 2. stability will be maintained for a period at least sufficient for the occupants to escape and to ensure the safety of firefighters; and
 3. there will be little risk of collapse onto adjoining property.

REQUIRED PERFORMANCE

DCP1.1 *External walls* of Class 1 *buildings*, other than of Class 10a *buildings*, located within 1.5 m of the allotment boundary or 3 m from other *buildings*, on the same allotment, must:

- (a) remain stable and not allow the passage of destructive heat, flames, smoke, or gases through them for an hour, in the event of a fire; and
- (b) not allow the passage of flames, smoke or gases through *windows* for an hour and such *windows* must not be openable.

DCP1.2 The *external wall* of a Class 10a *building* that is less than 1.5 m away from the allotment boundary other than with a road alignment or public space must not be *combustible*.

DCP1.3 A *common wall* must:

- (a) if it separates a Class 1 *building* from any Class other than 10a, remain stable and prevent the passage of destructive heat, flames, smoke or gases for an hour, in the event of a fire; and
- (b) if it separates a Class 1 *building* from a Class 10a *building* on different allotment must not be *combustible*.

DCP1.4 The underside of a floor separating 2 *sole-occupancy units* each being a separate domicile must not be *combustible*.

DCP1.5 Any *sarking-type* material used in a Class 1 *building* must have a low potential for ignition and limit the spread of fire if ignited.

DEEMED-TO-SATIFY PROVISIONS

DC1 Fire Resistance and Stability

DC1.1 External Walls of Class 1 Buildings

Except as permitted by Clause DC1.4 or CD1.5, an *external wall* of a Class 1 *building*, and any openings in that wall, must comply with clause DC1.2 if:

- (a) the wall is set back less than 1.5 m from an allotment boundary other than the boundary adjoining a road alignment or other public space; or
- (b) the wall is less than 3.0 m from another *building* on the same allotment other than a Class 10 *building*.

DC1.2 Class 1 Buildings: Construction of External Walls

External walls referred to in Clause DC1.1 must have an FRL of not less than 60/60/60.

Openings in *external walls* referred to in Clause DC1.1 must:

1. be protected with fire *windows* or glass block or other construction with an FRL of at least -/60/-; and
2. not be fitted with openable *windows*.

DC1.3 Class 10a Buildings: External Walls

An *external wall* of a Class 10a *building* other than an *open garage* must be of *non-combustible* construction or lined externally with *non-combustible* material if it is set back less than 1.5 m from the allotment boundary other than with a road alignment or public space.

DC1.4 Allowable Encroachments

The distance from an allotment boundary or between *buildings* must be the shortest distance measured from the outermost point of the *building* or *buildings* concerned, except that:

- fascia, gutters, downpipes, *non-combustible* eaves lining, and the like;
- masonry chimney backs, flues, pipes, cooling or heating appliances or other services;
- light fittings, electricity or gas meters, aerials or antennae;
- pergolas or sun blinds; and
- unroofed terraces, landings, steps or ramps, not more than 1 m in height,

may encroach into that distance if the distance to the boundary is not reduced to less than 1 m nor the distance between the *buildings* to less than 1.5 m.

DC1.5 Exceptions

Clause DC1.1 does not apply to:

- (a) an *external wall* that previously complied with this Part and is reclad, if the recladding does not reduce the distance to the boundary or *building* by more than 150 mm; or
- (b) an open garage.

DC1.6 Common Walls

A *common wall* must:

- (a) be of masonry or concrete, or be fully lined with *fire-protective covering* and extend to the underside of a *non-combustible* roof or not less than 450 mm above a roof with a *combustible* lining;
- (b) have an FRL of not less than 60/60/60 if it separates Class 1 *buildings*, or a Class 1 *building* and a Class 10a *building*, on different allotments; or

(c) be lined with a *non-combustible* material if it separates Class 10a *buildings* on different allotments.

DC1.7 Separating Floors

The underside of a floor separating *sole-occupancy units*, each being a separate domicile and located one above the other, must be lined with material with an FRL of not less than 30/30/30.

DC1.8 Sarking-type Materials

Any *sarking-type material* used in a Class 1 *building* must have a Flammability Index of not more than 5.

Section

DD



ACCESS AND EGRESS

THIS SECTION APPLIES DWELLINGS AND
OUTBUILDINGS (CLASS 1 & CLASS 10)

Contents

PERFORMANCE REQUIREMENTS.....	1
OBJECTIVES 1	
DDP1 Access & Egress	1
DDP2 Access for People with Disabilities	1
REQUIRED PERFORMANCE.....	1
DDP1.1 Stairways, Ramps and Exits.....	1
DDP2.1 Access for People with Disabilities	1
DEEMED-TO-SATISFY PROVISIONS	2
DD1 CONSTRUCTION OF EXITS	2
DD1.1 Treads and risers	2
DD1.2 Curved stairs	2
DD1.3 Balustrades	3
DD1.4 Parapets on flat roofs	4
DD1.5 Number of exits	4
DD1.6 Ramp in exits	4
DD1.7 Dimensions of exits.....	4
DD2 ACCESS FOR PEOPLE WITH DISABILITIES	4
DD2.1 Access to Buildings.....	4

PERFORMANCE REQUIREMENTS

OBJECTIVES

DDP1 Access & Egress

The design, construction, *alteration*, operation, maintenance and demolition of *buildings*, and construction sites must:

- (a) safeguard people from injury during movement into, within, and out of *buildings* and sites; and
- (b) safeguard people from injury resulting from the movement of vehicles on the site.

DDP2 Access for People with Disabilities

The design, construction, *alteration*, operation, maintenance and demolition of *buildings*, and construction sites must ensure that a person with disability is able to approach a *building* and site, enter it and adequately carry out activities and functions where required to be *accessible*.

REQUIRED PERFORMANCE

DDP1.1 Stairways, Ramps and Exits

A Class 1 or 10 (a) *building* must be so designed and constructed that the following are fulfilled:

- Stairways, ramps and passageways must be such as to provide safe passage for the users of the *building*.
- Stairways, ramps, floors and balconies, and any roof to which people normally have access, must have bounding walls, balustrades or other barriers where necessary to protect users from the risk of falling.
- Stairways must provide safe and reasonably comfortable dimensions for goings and risers. In any case the *pitch* of the stairway must be maintained within limits of 23° and 42°.
- If any ramp is used the slope must not exceed 1:12.
- A Class 1 *building* must have provision for fast exit during any emergency.

DDP2.1 Access for People with Disabilities

For Class 1, 2, and 10 *buildings*, it is not mandatory to provide access for people with disabilities.

If the occupants require disabled access, or the *building* is to be future-proofed to allow disabled access, access requirements shall be as per Part ND3.

DEEMED-TO-SATISFY PROVISIONS

DD1 Construction of Exits

DD1.1 Treads and Risers

- (a) A stairway must be suitable to provide safe passage in relation to the nature, volumes and frequency of likely usage.
- (b) A stairway in any *building* satisfies (a) if it has:
1. not more than 18 risers in each flight; and
 2. going and riser dimensions in accordance with Figure DD1.1 and Table DD1.1 that are constant throughout each flight;
 - a) risers which do not have any openings that would allow a 100 mm sphere to pass through between the treads;
 - b) treads which have a non-slip finish or a suitable non-skid strip near the edge of the nosing;
 - c) treads of solid construction (not mesh or other perforated material) if the stairway connects more than 3 *storeys*; and
 - d) the tread must not exceed the going by more than 20 mm.

DD1.2 Curved Stairs

Curved stairs must comply with the relevant requirements of DD1.1, as well as the following:

- (a) For the purposes of satisfying Table DD1.1, the going must be measured:
1. along halfway across the width of the stair where the clear width is less than 900 mm; and
 2. 300 mm from each side of the stair where the clear width is 900 mm or more.
- (b) All steps must have the same uniform taper.
- (c) The going at the narrow end of the steps must be not less than 75 mm.
- (d) Winders are not permitted.

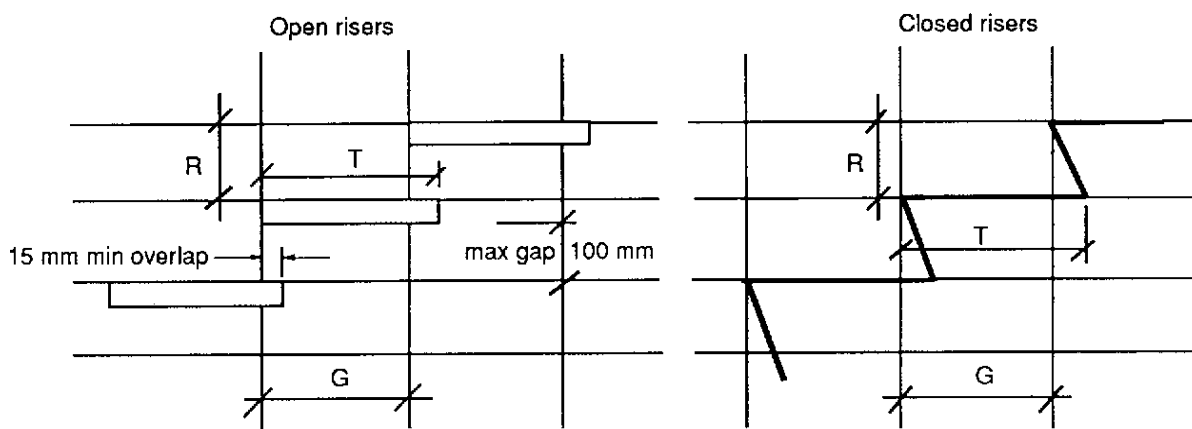

Note: R = Riser
G = Going
T = Tread

FIGURE DD1.1 MEASUREMENT OF RISER GOING AND TREAD

TABLE DD1.1: RISER DIMENSIONS (mm) TO MATCH GOING

Pitch	GOING (mm)											
	230	240	250	260	270	280	290	300	310	320	330	
42°												
41°	200											
40°	192	200										
39°	186	194	200									
38°	180	187	195	200								
37°	173	181	188	196	200							
36°	167	174	182	188	196	200						
35°	161	168	175	182	189	195	200					
34°	155	162	168	175	182	188	195	200				
33°	149	156	162	169	175	181	188	195	200			
32°		144	156	162	168	174	181	187	194	200		
31°			150	156	162	167	174	180	186	192	198	
30°				150	156	161	167	173	179	185	190	
29°					150	155	161	167	173	179	183	
28°						150	155	160	165	170	175	
27°							148	153	158	163	168	
26°								146	151	156	161	
25°										149	154	
24°												147

Note:
Actual riser dimension may be selected to suit the inter landing height. However, the value of the riser dimension must not be outside the maximum or minimum dimensions shown for each value of going.

DD1.3 Balustrades

- (a) A continuous balustrade must be provided along the side of any stairway or ramp, or any corridor, hallway, balcony, bridge or the like, if:
1. it is not bounded by a wall; and
 2. the change in level is more than 1 m.
- (b) A balustrade must prevent, as far as practicable:
1. children climbing over or through it;
 2. persons accidentally falling from the floor; and
 3. objects which might strike a person at a lower level accidentally falling from the floor

surface.

- (c) At balconies a balustrade satisfies (b) if:
1. it has a height of not less than 930 mm above the balcony floor;
 2. the space between *balusters* or the width of any opening in the balustrade is not more than 100 mm except where the space between the rails or the height of the opening is not more than 100 mm;
 3. all parts of the balustrade more than 150 mm and less than 760 mm from the floor or nosings are vertical or otherwise do not provide a toehold; and
 4. it does not have any openings more than 100 mm wide within 150 mm of the floor level.
- (d) In stairways and ramps (including access bridges and landings) a balustrade satisfies (b) if:
1. it has a height of not less than 865 mm above the nosing of the stair treads and the floor of the landing, balcony, corridor, hallway, access bridge or the like;
 2. the space between *balusters* or the width of any opening in the balustrade (including any openable window or panel) is not more than 100 mm except where the space between rails or the height of the opening is not more than 100 mm; and
 3. all parts of the balustrade more than 150 mm and less than 760 mm from the floor or nosings are vertical or otherwise do not provide a toehold.

DD1.4 Parapets on Flat Roofs

Where a flat roof or other elevated place has regular access, a parapet or balustrade of not less than 1 m height above the surface of the roof or elevated place must be provided. The width of any opening in the parapet or balustrade must not exceed 100 mm.

DD1.5 Number of Exits

Every Class 1 *building* must have two *exits*. At least one of these *exits* must provide easy means of egress in case of any emergency without security to the *building*. Such emergency *exits* may take the form of a trap door on an elevated floor or some such arrangement. *Windows* and other such opening used as emergency *exits* must have a minimum clear dimension of 560 mm and a minimum clear area of opening of 0.6 m². The shutter must be capable of opening to 90° to the wall. The top of the *window* sill must be no more than 900 mm from the floor inside. The height of the *window* sill from the ground or floor outside must not exceed 1,800 mm.

DD1.6 Ramp in Exits

A ramp may be used in place of a stairway. The gradient of any such ramp must be no steeper than 1:12.

DD1.7 Dimensions of Exits

The clear minimum width of a stairway or ramp must be 760 mm. The unobstructed height throughout must be not less than 2 m.

DD2 Access for People with Disabilities

DD2.1 Access to Buildings

While for Class 1, 2, 4 and 10 *buildings* it is not mandatory to provide access for people with disabilities., note should be taken of the guidelines set out in the Australian Department of Foreign Affairs (DFAT): Accessibility Design Guide: Universal Design principles for Australia's Aid Program – Annex E; Housing – (Available free of charge DFAT website).

If the occupants require disabled access, or the *building* is to be future-proofed to allow disabled access, access requirements shall be as per Part ND3.

Section

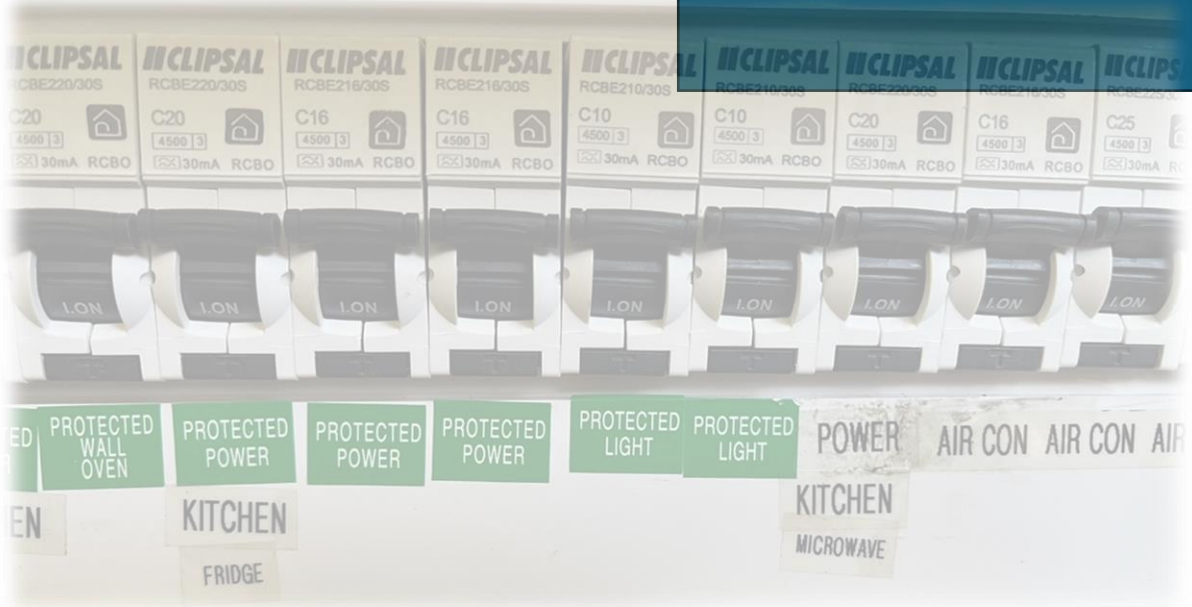

ELECTRICITY

THIS SECTION APPLIES DWELLINGS AND OUTBUILDINGS (CLASS 1 & CLASS 10)

Contents

PERFORMANCE REQUIREMENTS	1
OBJECTIVES	1
DEP1 Electrical Safety	1
DEP2 Amenity	1
REQUIRED REFORMANCE.....	1
DEP1.1 Electrical safety.....	1
DEP2.1 Amenity.....	1
DEP3.1 Energy Efficiency	1
DEEMED-TO-SATISFY PROVISIONS	3
DE1 ELECTRICAL SAFETY	3
DE1.1 General requirements	3
DE1.2 Plug sockets.....	3
DE1.3 Photovoltaic Energy System.....	3
DE2 AMENITY	3
DE2.1 Light switch layout.....	3

PERFORMANCE REQUIREMENTS

OBJECTIVES

All electrical work associated with a Class 1 or 10 *building* must meet the following objectives:

DEP1 Electrical Safety

It must prevent electrocution, burns, or fire.

DEP2 Amenity

It must satisfy the reasonable expectations of the occupants by ensuring that it is adequate for their intended use, both current and anticipated.

REQUIRED REFORMANCE

DEP1.1 Electrical Safety

The supply system must:

- (a) have suitable devices of adequate interruptive duty to automatically shut off the supply in the event of a fault or overload. Such devices must allow easy reinstatement of the supply after interruption;
- (b) have devices which are clearly identified and easily reached to isolate live parts from the incoming supply;
- (c) when the neutral of the supply is earthed, have socket outlet or plug-socket adaptor construction that would ensure that the live, neutral, and earth conductors can only be connected to the corresponding live, neutral, and earth conductors of the plug;
- (d) be adequately protected against damage arising from exposure to weather, water or excessive dampness mechanical loads and other such agents expected under normal conditions of use; and
- (e) ensure that the main switch is normally accessible only to the occupants.

In cases when the power utility provider establishes a Residual Current Device (RCD) at the meter board then the MEN link must be disconnected, and the neutral earthing must be omitted on the installation side. In such a case, the neutral will only be earthed on the power utility side of the supply.

DEP2.1 Amenity

The supply system must have an adequate number of plug sockets of minimum 10 amperes capacity to serve the reasonable anticipated needs of the occupants.

DEP3.1 Energy Efficiency

All *buildings*, including the operation and use of fixed appliances and building services (lighting, heating, domestic hot water, ventilation and air conditioning systems) must be designed and constructed to provide opportunities to reduce solar heat gain and promote cooling of the interior appropriate to:

1. the function and use of the *building*, facility and/or site;
2. the promotion of human comfort, health and safety in the interior environment;
3. the safe operation of storage, handling and fabrication of products and/or hazardous substances;
4. the geographic location, topography, hydrology and natural features;
5. *buildings*, facilities, site works and site servicing on adjacent property; and
6. environmental sustainability.

Key Energy Efficiency aspects should align with the Vanuatu National Policy (NEESAP), the URA Regulation and Vanuatu Electricity Supplies Act and the SIEAPI Guidelines on Energy Efficiency.

DEEMED-TO-SATISFY PROVISIONS

DE1 Electrical Safety

DE1.1 General Requirements

All electrical wiring and installations in or on any class 1 and 10 *building* must ensure safety from electric shock and fire. This requirement is satisfied if all electrical work associated with the *building* is done to comply with AS/NZS 3000 – Electrical installations: buildings, structures and premises (known as the Australian / New Zealand Wiring Rules). The capacity of the system must allow for the long term anticipated requirements of the occupants.

DE1.2 Plug Sockets

Plug sockets must:

- (a) have their individual switch;
- (b) be located so that:
 - 1. cords need not be taken across doorways; and
 - 2. trailing cords do not have to cross circulation routes;
- (c) not be located behind door-swings; and
- (d) in the kitchen be located 250 mm above worktops at the back of benches or on a return wall where it exits.

DE1.3 Photovoltaic Energy System

All photovoltaic energy systems shall fully comply with the requirements of AS/NZS 5033. Photovoltaic panel systems shall be fixed to the main structure of the *building*. Fixings shall be designed in accordance with the requirements of Section B – Structure.

DE2 Amenity

DE2.1 Light Switch Layout

The layout of light switches must follow the main nighttime circulation routes such as from the entrance hall to the living area to the bedrooms to the bathroom and toilet. Crossing any major space in the dark must be avoided. The switches must be located close to door openings.

Section

DF



HEALTH AND AMENITY

**THIS SECTION APPLIES DWELLINGS AND
OUTBUILDINGS (CLASS 1 & CLASS 10)**

Contents

PERFORMANCE REQUIREMENTS	1
OBJECTIVES 1	
DFP1 Design and construction	1
REQUIRED PERFORMANCE	1
DFP 1.1 Damp and weatherproofing	1
DFP1.2 Cooking and sanitary facilities.....	1
DFP1.3 Room sizes.....	1
DFP1.4 Light and ventilation	1
DFP1.5 Water supply plumbing	2
DFP1.6 Sanitary plumbing and drainage	2
DFP1.7 Sanitary disposal.....	2
DFP1.8 Roof drainage	2
DFP1.9 Site drainage	3
DEEMED-TO-SATISFY PROVISIONS	4
DF1 Damp and Weatherproofing; Site Drainage	4
DF1.1 Floor levels and site drainage	4
DF1.2 Building on land subject to dampness or flooding	4
DF1.3 Drainage of land external to building.....	4
DF1.4 Weatherproofing of roofs and walls	4
DF1.5 Pliable roof sarking	4
DF1.6 Water proofing and wet areas in buildings.....	4
DF1.7 Damp-proof course and mortars	5
DF1.8 Acceptable damp-proof courses	5
DF1.9 Damp-proofing of floors on the ground	5
DF2 Cooking and Sanitary Facilities	5
DF2.1 Facilities required	5
DF3 Room Sizes and Heights.....	6
DF3.1 Height of rooms	6
DF3.2 Reduced height permissible.....	6
DF3.3 Ceiling fans	6
DF 4 Light and Ventilation.....	6
DF4.1 Provision of natural light.....	6
DF4.2 Methods and extent of natural lighting	6
DF4.3 Natural light borrowed from adjoining room.....	6

SECTION DF – HEALTH AND AMENITY

DF4.4 Artificial lighting.....	6
DF4.5 Ventilation of rooms	7
DF4.6 Natural ventilation	7
DF4.7 Ventilation borrowed from adjoining room	7
DF4.8 Restriction on position of WCs and urinals	8
DF4.9 Airlocks.....	8
DF4.10 Sub-floor ventilation	8
DF4.11 Indoor Air Quality.....	8
DF4.12 Room Temperature	8
DF4.13 Ventilation.....	9
DF4.14 Air Conditioning.....	9
DF4.15 Mould Prevention.....	10
DF5 Water Supply Plumbing.....	10
DF5.1 General Requirements.....	10
DF5.2 Means of Compliance	10
DF5.3 Pipe Materials.....	Error! Bookmark not defined.
DF5.3 Pipes which are not easy to access	10
DF5.4 Access to domestic-type water heaters	10
DF5.5 Rainwater storage.....	11
DF 6 Sanitary Plumbing and Drainage	11
DF6.1 General.....	11
DF6.2 Means of Compliance	12
DF6.3 Fixture Unit Ratings.....	12
DF6.4 Trapping of Fixtures and Appliances	13
DF6.5 Fixture Discharge Pipes.....	13
DF6.6 Unvented Branch Drains	13
DF6.7 Venting.....	14
DF6.8 Design of Pipes and Drains.....	16
DF6.9 Gully Traps other than Floor Waste Gullies	19
DF6.10 Floor Waste Gullies.....	19
DF6.11 Inspection Openings.....	20
DF7 Sanitary Disposal	23
DF7.1 Specific requirements.....	23
DF7.2 Means of compliance	23
DF8 Roof Drainage	24
DF8.1 Design of roof gutters.....	24

SECTION DF – HEALTH AND AMENITY

DF8.2 Design of downpipes 25

DF8.3 Incompatible metals for gutters 25

DF8.4 Rainwater Storage 25

Relationship of rainfall, variability, roof area and storage volume 25

Design 26

Effect of roofing material and the environment..... 27

Tank material 27

Erection of rainwater tanks..... 28

Maintenance Considerations 28

SPECIFICATIONS

SPECIFICATION DF7.1: Sanitary Systems

PERFORMANCE REQUIREMENTS

OBJECTIVES

DFP1 Design and Construction

The design and construction of a Class 1 *building* must meet the following objectives:

1. freedom from unhealthy and uncomfortable damp and wet conditions;
2. adequate facilities for personal washing and the washing of clothes;
3. hygienic toilet facilities with adequate privacy and which will not be a nuisance to anyone or damage to the environment;
4. sufficient living space for privacy and comfort;
5. adequate light and ventilation consistent with the requirements of health hygiene and comfort;
6. where a public or private water supply exists, an appropriate safe and hygienic system of plumbing for the supply of water for domestic needs;
7. where a reticulated system of water supply is installed in the *building*, an appropriate system of drainage for the hygienic conveyance of *wastewater*;
8. where a roof drainage system is provided, it must give reasonable protection against the overflow of rainwater into the *building*; and
9. unhealthy pending of water in the allotment must not be allowed and the erection of the *building* or any *alteration* to it must not adversely affect the drainage of other allotments or of any public land.

REQUIRED PERFORMANCE

DFP 1.1 Damp and Weatherproofing

Buildings must be so *sited* and suitable damp and weatherproofing provided where necessary to prevent:

1. moisture or damp affecting the stability of the *building*;
2. the creation of any unhealthy or dangerous condition;
3. damage or defacement from moisture present at the completion of construction;
4. causing undue damage to adjoining property; or
5. the accumulation of surface water against the *building* or beneath the floor.

DFP1.2 Cooking and Sanitary Facilities

Adequate toilet and washing facilities must be provided for the occupants to allow reasonable comfort, hygiene, and privacy.

Cooking facilities shall be included within the *building* or immediately adjacent to the *building*.

DFP1.3 Room Sizes

The *floor area*, plan dimensions and ceiling heights of rooms and other spaces must be adequate for living purposes.

DFP1.4 Light and Ventilation

The standard of light and ventilation within *building* must be adequate for the occupants, having regard to health hygiene and comfort.

Buildings must be constructed to provide adequately controlled interior temperatures at a level appropriate to occupancy and use.

Habitable rooms within *buildings* must be provided with air that contains sufficient oxygen and limits contaminants to levels consistent with good health, safety, and comfort.

Air conditioning of interior spaces must provide sufficient air movement and adequate temperature to create a comfortable living environment appropriate to the number of occupants.

DFP1.5 Water Supply Plumbing

Plumbing for water supply must use materials which do not react with the water and thereby make it unsuitable for domestic use.

Suitable precautions must be taken to ensure that unsafe or unhygienic materials, or any pollution have no chance of entering the supply system.

The installation of hot water systems must not impair the safety of the users.

All concealed and difficult-to-access plumbing work must be suitably protected so that there is no likelihood of damage and leakage.

The plumbing must take into account the current and anticipated needs of the users and allow for the simultaneous use of the connected system by others.

Where rainwater from the roof runoff is the source of supply care must be exercised to ensure that there is no reasonable chance for the water to become contaminated.

Rainwater storage allowance must be made for lean years of rainfall.

DFP1.6 Sanitary Plumbing and Drainage

Sanitary plumbing must be laid to self-cleansing grades consistent with their discharge loading, unless other suitable arrangements are made to ensure the system is kept free of accretion of sewerage and other waste matter.

The size of *drains* and the layout of their connections must ensure the current and anticipated needs of the users.

The connections to sanitary installations must ensure that foul gases are not allowed to produce unhygienic conditions and are suitably vented.

Separate wastewater streams shall be provided in *buildings*.

DFP1.7 Sanitary Disposal

Sanitary disposal systems shall be designed such that:

1. disease transmitting flies and other insects do not have access to the excreta;
2. there is no nuisance to the public or the neighbours;
3. the subsoil water is not polluted if it is likely to be used for domestic purposes;
4. the biological oxygen demand (BOD) of any resulting effluent is limited to the requirements of the Department of Health so that streams rivers and oceans are not polluted;
5. the slab is smooth, flat and impermeable;
6. it is safe and private for all users; and
7. there is a hand-washing basin and soap within 3 m.

DFP1.8 Roof Drainage

The roof drainage system must be capable of handling peak intensities of rainfall as follows:

1. Eaves gutters and downpipes – a 20-year return intensity.
2. Internal box gutters, valley gutters and downpipes – a 100-year return intensity.

Any known local variation in rainfall intensity must be taken into account. Sufficient allowance must be made for the possibility of overflow into the *building* due to ripples and turbulence in the flowing water during cyclonic winds.

DFP1.9 Site Drainage

The immediate *site* around the *building* must have suitable drainage so that no ponding results and no adverse impact on adjacent sites and property.

Visible water must not be allowed to remain under or around for more than 1 hour after 10 minutes of maximum rainfall resulting from a storm with a return period of 5 years (including climate change scenario SSP3-7.0).

Flood waters or waves resulting from a storm or cyclone with a return period of 30 years (including climate change scenario SSP3-7.0). must not be allowed to enter a *building*.

DEEMED-TO-SATISFY PROVISIONS

DF1 Damp and Weatherproofing; Site Drainage

DF1.1 Floor Levels and Site Drainage

Floor levels of all new *buildings* must be a minimum of 300 mm above the natural ground level and, where possible, the ground around the *building* must slope away from the *building* at a minimum fall of 1 in 100 for 2 m.

The construction of a site drainage system and the position and manner of discharge of a stormwater drain must not:

1. result in the entry of water into any *building* or other allotments;
2. affect the stability of any *building*; or
3. create any unhealthy or dangerous condition within or around any *building*.

Stormwater Drainage must be designed according to AS/NZ 3500.3.

DF1.2 Building on Land Subject to Dampness or Flooding

One or more of the following measures must be carried out if it is warranted by the dampness of the *building site* or proneness to *flooding*:

- (a) The subsoil must be adequately drained.
- (b) The ground under the *building* must be regraded or filled and provided with outlets to prevent accumulation of water.
- (c) The surface of the ground under the *building* must be covered with a suitable damp-resisting material.
- (d) The *building* or structure floor level shall not be less than 1000mm above the known *flood* level at the site plus sea level rise for a median high emissions (SSP3-7.0) projection to the design working life or the *flood hazard level* as per B1.6.

DF1.3 Drainage of Land External to Building

A suitable system of drainage must be provided if paving, excavation or any other work on an allotment will cause undue interference with the existing drainage of rainwater falling on the allotment whether the existing drainage is natural or otherwise.

DF1.4 Weatherproofing of Roofs and Walls

Roofs and *external walls* must be constructed to prevent rain or dampness penetrating to the inner parts of a *building*.

DF1.5 Pliable Roof Sarking

Pliable roof *sarking-type* material used under roof or wall coverings must comply and be fixed in accordance with AS/NZS 4200.

DF1.6 Waterproofing and Wet Areas in Buildings

The following parts of a *building* must be impervious to water:

- (a) In any *building*: the floor surface or substrate in a shower enclosure, or within 1.5 m measured horizontally from a point vertically below the shower fitting, if there is no enclosure;
- (b) The wall surface or substrate:
 1. of a shower enclosure, or if the shower is not enclosed, within 1.5 m and exposed to a shower fitting, to a height of 1.8 m above the floor;
 2. immediately adjacent or behind a bath, trough, basin, sink, or similar fixture, to a height of 300 mm above the fixture if it is within 75 mm of the wall.

- (c) The junction between the floor and wall if the wall and floor are *required* to be impervious to water.
 (d) The junction between the wall and fixture if the wall is *required* to be impervious to water.

DF1.7 Damp-proof Course and Mortars

Moisture from the ground must be prevented from reaching:

1. the lowest floor timbers and the walls above the lowest floor joists;
2. the walls above the damp-proof course; and
3. the underside of a suspended floor constructed of a material other than timber, and the supporting beams or girders.

DF1.8 Acceptable Damp-proof Courses

A damp-proof course must consist of:

1. a material that complies with AS/NZS 2904; or
2. suitable termite shield placed on piers; or
3. other suitable material.

DF1.9 Damp-proofing of Floors on the Ground

If a floor of a room is laid on the ground on filling moisture from the ground must be prevented from reaching the upper surface of the floor and adjacent walls by:

1. the insertion of a vapour barrier in accordance with AS 2870; or
2. other suitable means.

DF2 Cooking and Sanitary Facilities

DF2.1 Facilities Required

Sanitary facilities, including cooking facilities, must meet the requirements as shown in Table 2.1.

Table DF2.1 Provision of Cooking and Sanitary Provisions

MINIMUM FACILITIES REQUIRED	
In all cases	a) facilities for the preparation and cooking of food, and for the cleaning of utensils. b) A suitable type of dry sanitation system as per Annexure 1 of Part DF7.1
When there is piped water supply to kitchen and ablution areas	c) a sink in a kitchen d) a shower or other adequate personal washing facilities e) clothes-washing facilities f) a closet pan and facilities for washing hands with soap dispenser or soap holder as per Annexure 2 to Part DF7.1 .
Where there is piped water supply only to a tap in the kitchen or up to a stand-pipe in the vicinity of the <i>building</i> or where there is no piped water supply	g) a paved raised platform with a paved area and drain around it h) a suitable type of privy as per Annexure 2 to Part DF7.1
NOTE: If any of these facilities are detached from the main <i>building</i> , they must be set aside for the exclusive use of the occupants of the <i>building</i> . Where the layout allows it, facilities in d), e), and f) can be in the same room.	

DF3 Room Sizes and Heights

DF3.1 Height of Rooms

Minimum heights between the ceiling and any framing excluding minor projections such as cornices, are:

1. Habitable room – average 2.4 m and minimum of 2.1 m; and
2. bathroom, shower room, water closet, laundry, pantry or the like – 2.1 m.

DF3.2 Reduced Height Permissible

These heights may be reduced if the reduction does not unduly interfere with the proper functioning of the room.

DF3.3 Ceiling Fans

Ceiling fans and other such appliances must be at a minimum vertical clearance of 2.1 m.

DF 4 Light and Ventilation

DF4.1 Provision of Natural Light

Natural lighting must be provided to all *habitable rooms*.

DF4.2 Methods and extent of natural lighting

Direct natural lighting must be provided by *windows* that:

- (a) have an aggregate light transmitting area measured excluding framing members, glazing bars or other obstructions of not less than 10% of the floor area of the room;
- (b) face:
 1. a court or other space open to the sky; or
 2. an open verandah, open carport, or the like;
- (c) are not less than a horizontal distance of 1 m from any boundary of an adjoining allotment that they face.

DF4.3 Natural Light Borrowed from Adjoining Room

Natural lighting to a room may come through a glazed panel or opening from an adjoining room (including an enclosed verandah) if:

- (a) the glazed panel or opening has an area of not less than 10% of the floor area of the room to which it provides light; and
- (b) the adjoining room has *windows* with an aggregate light transmitting area of not less than 10% of the combined floor areas of both rooms.

The areas specified above may be reduced as appropriate if direct natural light is provided from another source.

DF4.4 Artificial Lighting

Artificial lighting must be provided to *sanitary compartments*, bathrooms, shower rooms, airlock and laundries, if natural lighting of a standard equivalent to that *required* by DF4.2 is not available and the periods of occupation, or use of the room or space will create undue hazard to occupants seeking egress in an emergency.

DF4.5 Ventilation of Rooms

A *habitable room*, *sanitary compartment*, bathroom, shower room, laundry and any other room occupied by a person for any purpose must be provided with natural ventilation complying with DF4.6. Where it is not practical to provide natural ventilation for any *sanitary compartment*, bathroom, shower or laundry, it is permissible to substitute natural ventilation with a mechanical ventilation system. In such a case, the system must satisfy the requirements of AS 1668:2.

DF4.6 Natural Ventilation

Required natural ventilation must be provided by permanent windows, openings, doors or other devices:

- (a) with an aggregate opening or openable size not less than 10% of the *floor area* of the room *required* to be ventilated; and
- (b) which open to:
 1. a court, or space open to the sky; or
 2. an open verandah, open carport, or the like.

DF4.7 Ventilation Borrowed from Adjoining Room

Natural ventilation to a room may come through a *window*, opening, ventilating door or other device from an adjoining room (including an enclosed verandah) if:

- (a) the room to be ventilated or from which ventilation is borrowed is not a *sanitary compartment*;
- (b) ventilation is not borrowed from one bedroom to another or between a bedroom and the kitchen;
- (c) the *window*, opening, door or other device has a ventilating area of not less than 10% of the *floor area* of the room to be ventilated; and
- (d) the adjoining room has a *window*, opening, door or other device with a ventilating area of not less than 10% of the combined *floor areas* of both rooms.

Note: The ventilating areas specified may be reduced as appropriate if direct natural ventilation is provided from another source.

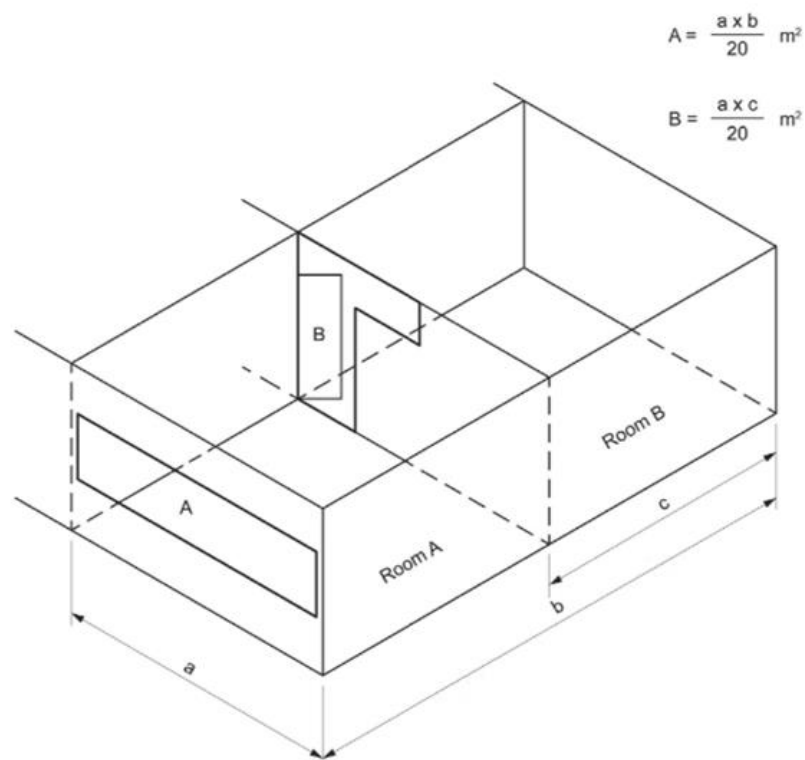

Figure 4.7 Method of Determining Areas of Openings for Borrowed Ventilation

DF4.8 Restriction on Position of WCs and Urinals

A room containing a closet pan or urinal must not open directly into:

1. a kitchen; or
2. a room for storage or consumption of food, except if it is in a *building* containing only one *habitable room*.

DF4.9 Airlocks

If a room containing a closet pan or urinal is prohibited under DF4.8 from opening directly to another room:

1. access must be by an airlock, hallway or other room; or
2. the room containing the closet pan or urinal must be provided with an exhaust fan.

DF4.10 Sub-floor Ventilation

Suitable provision must be made to prevent undue deterioration of the lowest floor of a *building* because of dampness, other conditions on the allotment or the design of the *building*.

The following would satisfy the requirements these provisions:

- (a) where timber is used, the floor framing must be suspended with an absolute minimum of 250 mm and an average minimum of 400 mm clearance from the ground underneath to the floor and the immediate surrounds of the *building*. The average clearance must be determined as the average of the clearances at the corners of a 3 m square grid covering the *building* plan. Subfloor ventilation must be provided with ventilation openings totaling not less than 3% of the peripheral vertical area between the ground and the boundary of the floor. These openings are to be spaced uniformly at not more than 1.8 m apart.
- (b) where other than timber is used the following must be provided:
 1. subfloor ventilation if the floor is suspended
 2. an impervious cover over the ground surface beneath the *building*; or
 3. the floor members suitably treated.

DF4.11 Indoor Air Quality

Buildings must have a means of collecting and/or removing the following from the rooms in which they are generated:

1. cooking fumes and odours;
2. excessive water vapor from laundering, utensil washing, bathing and showering;
3. odours from sanitary and waste storage spaces;
4. gaseous by-products and excessive moisture from commercial or industrial processes;
5. poisonous fumes and gases;
6. airborne particles; and
7. products of combustion.

Contaminated air must be disposed of in a way that avoids creating a nuisance or hazard to people and other property.

DF4.12 Room Temperature

Achieving a comfortable indoor temperature may be achieved through any, some, or all of the following:

1. insulation in walls, ceilings, floors, attic spaces to prevent heat, electricity, or sound from passing into or out of a room or structure;
2. high performance window glazing
3. natural ventilation;
4. external shading of windows and proper window coverings;
5. high-efficiency fans in living and attic spaces; or
6. energy-efficient mechanical air conditioning systems.

Release of heated air to the outside must be provided by the use of any, some or all of the following natural ventilation techniques, unless the building is fully air-conditioned by a mechanical system:

1. high ceilings (greater than 2.2 m);
2. windows/vents within 250 mm of the ceiling.

DF4.13 Ventilation

Ventilation systems in non-residential *buildings* must be equipped with:

1. exhaust outlets and plumbing vents a minimum of 6.0 m away from outdoor air intakes;
2. outdoor air intakes located at least 9.0 m away from sources of pollution including dumpsters, parking areas, driveways, loading docks, natural gas lines, wet cooling towers and garage doors / exhaust outlets;
3. outdoor air intakes must be protected with suitable mesh screens and filters; and
4. roof drainage that slopes away from outdoor air intakes;

and must:

5. account for the demands of any fixed combustion appliances; and
6. be sized and configured to accommodate future expansion of the building.

Natural ventilation must consist of permanent openings, windows, doors or other devices which can be opened and are of sufficient size and appropriately placed to provide effective air circulation.

Openings must be screened to prevent entry of birds, rodents, leaves, and other similar objects.

Larger openings must be placed on the downwind, or leeward, facade, and smaller openings on the breeze, or windward, facade to promote air circulation within the *building*.

Non-air-conditioned *buildings* must have most windows consist of louvred panels or other openable panels to promote air flow, as appropriate to occupancy and use.

Enclosed attic spaces and cathedral ceilings must have adequate ventilation that:

- (a) provides adequate cross-ventilation of enclosed attic spaces and enclosed cathedral ceilings; and
- (b) provides exhaust fans where needed.

DF4.14 Air Conditioning

A mechanical air-handling system installed in a *building* must:

1. control the circulation of objectionable odours;
2. control the accumulation of harmful contamination by micro-organisms and pathogens; and
3. be in accordance with AS 1668.2 and AS/NZS 3666.1.

Air conditioning units must have an appropriate energy-savings certificate from a recognized agency, such as Energy Star and must have suitable corrosion protection for the environment it is located in.

Ducts must be appropriately sized for room-to-room cooling requirements and to maximise efficiency, with the layout designed to reduce duct length as much as possible.

Ducts must be properly sealed with low volatile organic compound (VOC) mastic so that ductwork is airtight (duct tape is not permitted).

Rooms must have adequately sized return ducts or doors that are undercut sufficiently to allow air flow to avoid any situation of negative pressure.

Effective delivery of clean supply air must be sufficiently provided to reduce the impact of pollutants generated in the interior spaces.

Mechanical air conditioning systems must have any or all of the following energy-saving equipment to control the volume of cooled air produced daily and promote energy efficiency:

- (a) variable speed controls;
- (b) timer-switches for rooms to control air temperature according to time of day and use of the *building*;
- (c) demand-controlled ventilation that adjusts outdoor air intake to maintain optimal indoor air quality;
- (d) isolate fan motors from supply air streams.

Mechanical air handling equipment must have air filtration suitable for the application required.

All air conditioning systems are to undergo a commissioning process to ensure the functional and environmental performance.

DF4.15 Mould Prevention

Cross-ventilation through the *building* interior must be provided through appropriate layout of rooms, and placement and size of doors, windows, and vents.

Buildings with air conditioning must have positive air pressure to promote proper air circulation.

Methods for prevention of water accumulation listed in DF1 above must be followed.

Stand-alone sanitary compartments not connected to a bathroom, laundry or other sanitary room must provide ventilation through either a window or mechanical ventilation (see Part DF4.5).

DF5 Water Supply Plumbing

DF5.1 General Requirements

The plumbing work for water supply must ensure:

1. the appropriateness of the materials and products used;
2. the correct sizing of water services for the intended use;
3. the control of cross-connections and prevention of backflow;
4. adequate care in the installation of the services;
5. suitable provision of main and subsidiary storage as *required*;
6. adequate connections to sanitary services without endangering health and hygiene; and
7. that the installation of hot water systems provide safe and adequate service.

DF5.2 Means of Compliance

The requirements of DF5.1 are satisfied if all plumbing for water supply is carried out to the relevant provisions of:

1. AS/NZS 3500 Part 1 – Water Services and its amendments;
2. AS/NZS 3500 Part 4 – Heated Water Services and its amendments; and
3. AS/NZS 2845.1 Water Supply Backflow Prevention Devices – Part 1: Materials, Design and Performance Requirements and its amendments.

DF5.3 Pipes that Are Not Easy to Access

Particular attention is drawn to the provisions in AS/NZS 3500 – Parts 1 and 4 which prohibit the installation of pipes and fittings of certain materials in locations which are concealed or difficult to access. These include pipe made of ABS, galvanized steel, polybutylene and UPVC. Pipes and fittings made of copper, copper alloy, stainless steel, ductile iron, cast iron and polyethylene when used in concealed or difficult to access locations must follow the special precautions specified in AS/NZS 3500 – Part 1 and 4.

DF5.4 Access to domestic-type water heaters

A household water heater which is installed in a building must:

1. be supported on construction sufficient to carry its full capacity weight and any possible wind or earthquake loads;
2. be positioned to enable adequate access for operation, maintenance and removal; and
3. provide suitably for any overflow, especially if installed in a concealed location.

AS/NZS 3500 – Part 4 is the relevant standard for the installation of a household water heater.

DF5.5 Rainwater Storage

Where rainwater is collected and stored, the storage and distribution must reasonably ensure that the water is not contaminated by unsafe or unsuitable materials. The capacity of the catchment and storage must be adequate to provide a continued supply of water during years of low rainfall.

The details given in **Part DF9** meet the requirements of this clause.

DF 6 Sanitary Plumbing and Drainage

DF6.1 General

General Requirements

Sanitary plumbing and drainage must ensure:

1. the appropriateness of the products and materials used;
2. the correct sizing of drainage services for the intended use;
3. adequate care in the installation of the services including the provision of appropriate grades; and
4. that foul gases are not allowed to produce unhygienic conditions or any nuisance to anyone.

Some Common Terms

Apart from the defined terms given in A1.1, the following terms used in this Part are explained:

Nominal size (DN)

While converting to metric dimensions, some manufacturers of pipes and fittings have used hard conversion whereas others have used soft conversion. For these and other reasons, it is impractical to specify exact pipe and fitting dimensions. All pipes and fittings in this Part are therefore specified by their nominal size. This is indicated by the letters "DN" followed by a number.

Since this number is only an approximation of the actual size, it is not subject to exact measurement and must not be used in calculations. The nominal size is thus only a numerical designation of the size which is common to all components in a piping system (other than components such as steel tubes which are designated by their outside diameter and other components by their thread size). It is only a convenient round number for reference purposes and is loosely related to the manufacturing dimensions.

Trap

A trap is a device which retains a water seal for preventing the escape of *sewer* gases from sanitary plumbing. Figure DF6.1.2 shows two common types of fixture traps. There are also traps integral with gullies, water closet pans, etc.

The water seal can be broken by self-siphonage or induced siphonage as well as by positive pressure of the gases breaking through the seal. It is also possible for the seal to be dried out by prolonged non-use of the associated part of the system.

The best means of preventing the loss of the seal by siphonage or by positive pressure is to vent the trap to the outside air. Air admittance valves (AAVs) may be used where atmospheric venting of a trap cannot be achieved.

Figure DF6.1.2: Examples of Fixture Traps

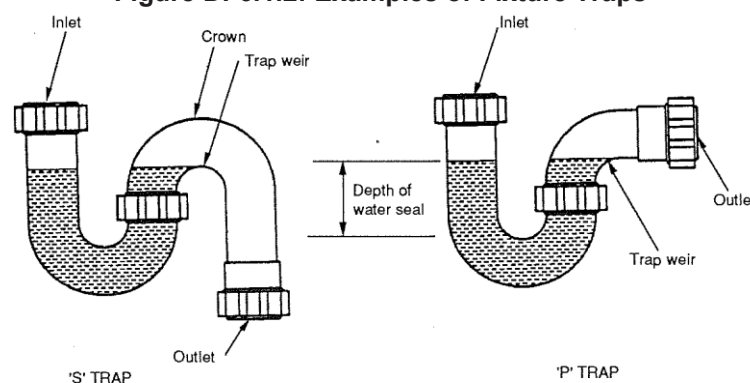

Fixture discharge pipe

This is the discharge pipe to which any single sanitary fixture is connected.

Gullies

A gully is an assembly used for providing a water seal when handling the discharge from only *waste fixtures* and not any *soil fixture*. The water seal prevents the escape of foul gases into the *building* or into the atmosphere in the vicinity of the assembly.

It is a disconnector gully when it provides a separation through the water seal, between the discharge from *waste fixtures* and the rest of the sanitary system.

A floor waste gully is a disconnector gully used inside a *building* with a floor grating or waste outlet fitting on a riser pipe. Discharge pipes from *waste fixtures* may also connect to a floor waste gully.

An overflow relief gully functions as a self-cleaning trap and is provided with a loosely fitted grating. This allows for the relief of any possible surcharge or overflow from the *drain*. The riser of the gully may have inlets for discharge from *waste fixtures*.

DF6.2 Means of Compliance

The requirements of DF6.1 are satisfied if all sanitary plumbing and drainage works are carried out to the relevant provisions of AS/NZS 3500 – Part 2 – Sanitary plumbing and sanitary drainage, as well as this part of the Code, in particular **Annexure 2 to Part DF7.1**

DF6.3 Fixture Unit Ratings

In the design of discharge pipes and *drains*, the *fixture unit* ratings shown in Table DF6.3 must be used. For the fixtures listed in Table DF6.3, the maximum unvented length of the associated fixture discharge pipe must not exceed 2.5 m except that this may be 6 m for a water closet pan with a DN100 trap and discharge pipe. The length of the pipe is measured along the center line from the weir of the trap to the point of connection to a graded discharge pipe, *drain*, *stack* or other drainage trap.

Table DF6.3: Fixture Unit Ratings

Fixture	Nominal size of trap outlet and fixture discharge pipe	Fixture unit rating
Basin	DN32 or DN40	1
Bath (with or without shower)	DN40	4
Bidet	DN40	1
* Clothes washing machine	DN40	5
* Dishwashing machine	DN40	3
Floor waste gully: without fixture	DN50	0
with fixture	DN40 or DN 50	as per fixture rating
Laundry trough	DN40 or DN 50	5
Shower	DN40 or DN50	2
Sink: less than 45 liters	DN40	2
more than 45 liters	DN50	3
Water closet pan	DN80 or DN100	5
* (i) When clothes washing machine connects to a trough trap, only the trough unit fixture rating is considered.		
* (ii) When a dishwashing machine connects to a sink trap only the sink <i>fixture unit</i> rating is considered.		

DF6.4 Trapping of Fixtures and Appliances

The discharge from all sanitary fixtures and appliances must pass through traps before entering the drain, soil/pipe or waste pipe. The fixture trap must retain a water seal of:

1. 50 mm for traps of size DN50 or less; and
2. 75 mm for traps of size greater than DN50.

The traps must be located as close as possible to the fixture and not farther than 600 mm from the fixture outlet, except in case of permitted fixture pairs and floor waste gullies.

The following fixtures may be connected in pairs to a single fixture trap:

1. Wash basins
2. Sinks
3. Laundry troughs
4. Showers.

The fixture pairs must be connected so that the center-to-center distance between their outlets is no more than 1.2 m.

DF6.5 Fixture Discharge Pipes

Minimum grades

Discharge pipes must be laid to the minimum grades shown in Table DF6.5.1.

Table DF6.5.1: Minimum Grades of Discharge Pipes

Nominal size	Minimum grade
DN32	1 in 30
DN40	1 in 40
DN65	1 in 40
DN80	1 in 60
DN100	1 in 60

Connections

The connection of any fixture discharge pipe to a graded discharge pipe or between two graded discharge pipes must be made as follows:

- (a) with 45 degree or sweep junction fittings;
- (b) where the pipes are of different sizes:
 1. the soffits of both must be in continuous alignment; and
 2. where an unequal junction fitting is used the soffit of the branch pipe must be at the same level or higher than the soffit of the pipe to which it connects; and
- (c) the level of the trap or floor waste gully weir must be at a higher level than the soffit of the graded discharge pipe to which it connects.

Cleaning Eyes

Fixture discharge pipes must have accessible cleaning eyes at all bends or inspection chambers with maintenance holes at all bends as indicated in Part DF6.11.

DF6.6 Unvented Branch Drains

Where the risk of escape of dangerous and unpleasant gases into occupied premises is minimal the venting of branch drains is not required, which is generally the case for wastewater from basins, baths, showers and other floor waste gullies. However, all of the limitations given in the following sub-clauses must be met in such cases.

Limitations on Location or Nature of Connection

The connection of any unvented branch *drain* to a vented *drain* must be located at the ground floor level and the vented *drain* installed on grade below or above ground.

In the case of an unvented *drain* receiving discharge from only *waste fixtures*, it must connect to a gully.

An unvented drain other than in (b) must be connected to a disconnector gully or the connection must be from a discharge pipe serving a single fixture, with the length of the discharge pipe being:

1. less than 3.5 m when serving a waste fixture; or
2. less than 3.0 m when serving a soil fixture.

Limitations on size, length, and bends

(a) The size of any unvented branch drain must comply with the limitations given in Table DF6.6.2.

Table DF 6.6.2: Size of Unvented Branch Drains

Nominal size	Maximum sum of fixture unit loadings discharging into the branch drain
DN65	5 (but not from a water closet pan) or 8 from one floor waste gully
DN80	12 (but not from a water closet pan)
DN100	30 (no more than 2 water closet pan connected)

(b) The length of an unvented branch drain together with that of the fixture discharge pipe must not exceed:

1. 8.5 m from the weir of the fixture trap
2. 10 m to a disconnector gully; and
3. 2.5 m from the reducer to the weir of the trap, where the fixture discharge pipe is of smaller size than the unvented branch drain.

(c) The maximum vertical drop from the crown of the trap to the top of the vented drain to which the unvented branch drain connects must not exceed:

1. 1.5 m in the case of basins and bidets; and
2. 2.5 m in the case of all other fixtures.

(d) The total combined number of long bends in a fixture discharge pipe and branch drain, up to the connection with a vented drain must be limited to:

1. 2 horizontal and 2 vertical with basins and bidets; and
2. 2 horizontal and 3 vertical with all other fixtures. The distance between any adjacent horizontal bends must be not less than 300 mm and the vertical drop between two adjacent vertical bends must not exceed 2 m.

Note: A bend of 45° or less is not considered to be a bend for the purposes of this clause.

DF6.7 Venting

In order to prevent the escape of dangerous and unpleasant gases into occupied premises and to ensure that water seals in traps are not destroyed by siphonage, adequate venting must be provided for all fixture discharge pipes and drains, at least for blackwater from water closet pans, except as allowed by DF6.6. Venting is only for consideration for wastewater from basins, baths, showers and other floor waste gullies.

Trap Vents

The minimum size of a trap vent must be related to the nominal size of the fixture trap as follows:

Size of fixture trap	Size of trap vent
DN32 or DN40	DN32
DN50 to DN100	DN40

Every trap vent must be extended upward at least 50 mm above the *flood* level rim of the fixture. This may be accomplished in one of the following ways:

- (a) As a vertical vent to open air, the outlet of which is no closer than 900 mm from any opening to the *building*;
- (b) On an ascending grade of at least 1: 80 and then:
 - 1. as a vertical vent to the open air; or
 - 2. to a connection with a vertical or branch vent.
- (c) Take the vent above the *flood* level rim of the fixture, then loop it down either vertically or on a downward grade of 1: 80 and connect to a vertical or branch vent.

Trap vents must be located no closer than 75 mm and no farther than 1,500 mm from the crown of the trap.

Drain Vents

(a) General

Vents in *drains* must be provided:

- 1. at the upstream end of any drain;
- 2. at the upstream end of any branch drain to which a fixture trap or floor waste gully is connected and if the distance from the weir of the trap to the vented drain exceeds 8.5 m;
- 3. at the upstream end of any DN100 branch drain to which 3 or more water closet pans are connected; and
- 4. at the upstream end of any DN100 branch drain to which no more than 2 water closet pans are connected.

(b) Location

The upstream vent of any *drain* must be connected:

- 1. at or close to the end of the drain; or
- 2. at the vent extension of a stack located at or near the upstream end of the drain.

In either case it is permissible to have an unvented length of drain upstream of the vent connection if the unvented length complies with DF6.6.

(c) Size of vents

The minimum size of an upstream vent of any *drain* is DN40. Subject to this, the vent must be sized by using the ratings given in Table D6.7.2.

Table DF6.7.2: Size and Rating of Drain Vents

Fixture units discharging into drain	Vent rating	Vent size
1 to 10 (incl)	0.5	DN40
10 (excl) to 30 (incl)	1	DN50
30 (excl) to 175 (incl)	2	DN65
175 (excl) to 400 (incl)	3	DN80

When two or more vents are directly connected to the *drain*, these can take the place of a single vent provided the sum of their ratings is not less than the rating *required* for venting the *drain*.

Termination of Vents

- (a) Vent pipes from waste fixtures discharging into disconnector gullies and from gullies located within *buildings* must be vented independently and not be interconnected to any other system vent. Such vents must terminate in the open air:
 - 1. at a height of at least 50 mm above the overflow level of the associated fixture;
 - 2. at least 900 mm from any opening to the *building* which is within a horizontal distance of 3 m from the vent; and
 - 3. not less than 150 mm above its point of penetration through any roof covering.
- (b) Vents other than in (a) must terminate in the open air:
 - 1. not less than 600 mm above any opening into any *building* which is within a horizontal distance of 3 m from the vent;
 - 2. not less than 150 mm above its point of penetration through any roof covering;

3. not less than 3 m above any trafficable roof deck which is within a horizontal distance of 3 m from the vent;
4. not less than 2 m above or 600 mm below any chimney or similar opening within a horizontal distance of 3 m from the vent;
5. not less than 5 m from any air intake; and
6. not less than 600 mm above any cave, coping or parapet which is within a horizontal distance of 600 mm from the vent.

DF6.8 Design of Pipes and Drains

Sizing of Discharge Pipes

Discharge pipes must be not less than the size of the fixture traps to which they are connected. The size must be determined from Table DF6.3 and take into consideration:

- the sum of the *fixture unit* rating of all fixtures connected to the pipe;
- the proposed pipe gradient; and
- the maximum *fixture unit* loadings given in Table DF6.8.1.

Table DF6.8.1: Maximum Fixture Unit Loadings for Graded Discharge Pipes

Grade	Nominal pipe size (mm)				
	40	50	65	80	100
1 in 20	6	15	51	65	376
1 in 30	5	10	29	39	248
1 in 40	4	8	21	27	182
1 in 50	x	x	x	20	142
1 in 60	x	x	x	16	115

Note

- (a) x indicates that the combination of pipe size and gradient is not permitted.
- (b) Not more than two W.C. pans are to be connected to any DN100 pipe.

Sizing of Drains

The size of a vented *drain* must be determined by taking into account the total number of *fixture units* (obtained from Table DF6.3) discharging into the *drain*.

- (a) Normal grades

The minimum normal grade of *drains* must be as given in Table DF6.8.2a.

Table DF6.8.2a: Minimum Gradient of Drains

Nominal size (mm)	Minimum grade
80	1 in 60
100	1 in 60
125	1 in 80
150	1 in 100

- (b) Maximum fixture unit loadings for vented drains

The *fixture unit* loadings for vented *drains* must not exceed the values given in Table DF6.8.2b for the size and grade of the *drain* shown.

Table DF6.8.2b: Maximum Fixture Unit Loadings for Vented Drains

Grade	Nominal pipe size (mm)			
	80	100	125	150
1 in 20	215	515	1,450	2,920
1 in 30	140	345	1,040	2,200
1 in 40	100	255	815	1,790
1 in 50	76	205	665	1,510
1 in 60	61	185	560	1,310
1 in 70	50	140	485	1,180
1 in 80	42	120	425	1,040
1 in 90	x	x	380	935
1 in 100	x	x	340	855
1 in 120	x	x	x	725
1 in 150	x	x	x	595

Note: x indicates that the combination of nominal size and grade is not permitted.

(c) Reduced grades

Where the minimum grades given in Table DF6.8.2a are not achievable, *drains* may be laid at the reduced grades given in Table DF6.8.2c. In such a case, the minimum *fixture unit* loadings given in the Table must be connected in advance of the top end of the reduced grade. Where even these reduced grades cannot be achieved provision must be made for regular and automatic flushing of the *drain*.

Table DF6.8.2c: Minimum Fixture Unit Loadings for Reduced Grade Drains

Reduced grade	Nominal pipe size (mm)			
	80	100	125	150
	Minimum <i>fixture unit</i> loading			
1 in 70	9	10	See Table DF6.8.2A	
1 in 80	10	18	“	“
1 in 90	x	x	27	“
1 in 100	x	x	38	“
1 in 120	x	x	x	75
1 in 150	x	x	x	160

Note: x means that the grade is not permitted unless special automatic flushing arrangements are made.

(d) A drain must not be oversized for the only purpose of using a lower gradient than the minimum gradient given in Table DF6.8.2A. The size of a drain must not reduce in the direction of flow.

Cover Over Drains

(a) *Drains* must be protected against any mechanical damage and deformation resulting from the loads over them. Adequate cover must be provided to comply with Table DF6.8.3 unless exempted under (b).

Table DF6.8.3 Minimum Depth of Cover Over Drains

Location	Minimum cover from top of pipe socket to ground surface (mm)	
	Pipes of cast iron	Pipes of other materials
Household driveways	300	450
Other locations where no vehicular loadings are expected	Nil	300

(b) Where it is not practical to provide the minimum cover to Table DF6.8.3, drains must be covered by a sandy overlay of at least 50 mm and provided with:

1. 75 mm thick concrete paving where light vehicular traffic may be expected; and
2. 50 mm thick concrete paving at other locations where vehicular traffic is not expected.

The paving must be symmetric to the *drain* alignment and must have a minimum width equal to the depth of the base of the *drain* from the top of the paving plus 300 mm.

Drains close to buildings

(a) Drains under *buildings*:

Where it cannot reasonably be avoided, *drains* may be laid below ground under *buildings*, in which case:

1. inspection openings must be provided at both ends of the *drain* adjacent to the *building*; and
2. a minimum of 50 mm of sandy overlay provided over the pipe and below a reinforced concrete floor slab; or
3. the *drain* must be protected from damage.

(b) Proximity of *buildings*:

1. Where a *drain* is to be laid parallel to a footing, the excavation for it must clear a line at 45° from the extremity of the footing (See Figure DF6.8.4).
2. Where a *drain* crosses a strip footing, the angle of crossing must be not less than 45° and the top of the *drain* must clear the bottom of the footing by not less than 50 mm.

Figure DF68.4: Drain Laid Parallel to a Footing

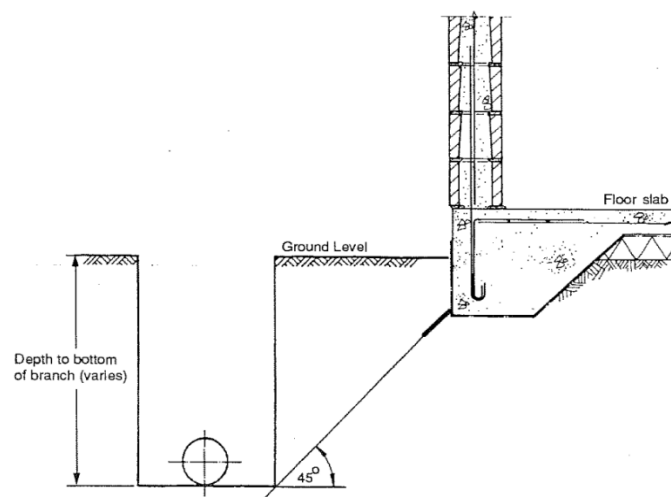

(c) *Building* over drains:

Where it is not practical to divert *drains* in order to avoid erecting *buildings* over them, the restrictions listed in (a) and (b) must be observed; and other appropriate engineering precautions taken against damage.

DF6.9 Gully Traps other than Floor Waste Gullies

Gully traps may be used:

- as overflow relief gullies to provide in the event of *sewage* surcharge; or
- to provide disconnection between waste discharges and the remainder of the sewerage installation (disconnecter gullies).

General

(a) A gully must be installed such that:

1. it is supported on a minimum 75 mm thickness of concrete of 17.5 MPa grade; and
2. it is protected from damage at floor level by a concrete surround of minimum width and depth of 75 mm.

(b) The following discharges must not be allowed into a gully:

1. any *soil fixture*; and
2. any rainwater drainage from the roof or ground.

(c) The gully must have its water seal maintained from a *waste fixture* or floor waste gully. The maximum length of unvented *waste pipe* discharging into the gully must be 2.5 m from basins or bidets, 6 m from all other waste gullies and fixtures with DN50 or smaller pipes, and 8.5 m from floor waste gullies and fixtures with DN65 or larger pipes.

Overflow Relief Gullies

At least one overflow relief gully must be installed in a *drain* which is connected to a public *sewer*.

(a) Size

The size of the overflow relief gully is related to the size of the main *drain*. For a size of main *drain* of DN80, the gully must also be DN80. For main *drains* of DN100 to 150 size, the gully must be DN100.

(b) Location

An overflow relief gully must be located within the property, external to the *building*, as far as is practicable from the downstream end of the *drain*, and so that the top of the gully is accessible and positioned where any overflow can be easily noticed.

(c) Height

A minimum height of 150 mm must be kept between the top of the overflow gully riser and the lowest fixture connected to the *drain*. The point of measurement on fixtures is given in Table DF6.9.2.

Table DF6.9.2: Point of Measurement of Fixtures for Height Above Overflow Level of Gully

Fixture	Point of measurement
<i>Soil fixture</i> with integral trap	Level of water seal surface
Floor waste gully or shower outlet	Top surface level of grate
Other fixtures	Top surface level of fixture outlet

Disconnecter Gully Traps

Where installed within a *building* these must:

- (a) have the gully riser extend to floor level and be sealed with an airtight removable cover; and
- (b) a DN50 vent pipe must branch from the riser at an upward grade of not less than 1 in 80 and terminate with a grating at an *external wall* of the *building* above any likely *flood* level. Alternately the vent pipe can terminate as in DF6.7.3(a). No other fixture or appliance must be connected to the vent pipe.

DF6.10 Floor Waste Gullies

Floor waste gullies are functionally similar to fixture water traps. Shower outlets may be used as floor waste gullies. Any *waste fixture* may be connected to a floor waste gully. No trap is *required* other than

for discharge outlets from basins. For other than basins, the maximum length of the untrapped *waste pipe* must not exceed 1.2 m. if any of the fixtures is trapped, the maximum length of the *waste pipe* is allowed to be up to 2.5 m. However, the traps must not be vented. With the exception of allowed fixture pairs, each fixture must connect individually with the gully at a grade of not less than 1 in 40.

Size

The outlet size of a floor waste gully trap is based on the total *fixture units* of the fixtures and appliances discharging into it. The outlet size must be:

- DN50 for a total fixture unit rating of 3 units or less; and
- DN65 to DN100 for a total fixture unit rating of 10 or less.

A DN50 outlet and a DN50 riser may be used if the sole function of the gully is to dispose of water spillage and wash down water. All other gullies must have a minimum riser size of DN80 at floor level. A floor waste gully must have an accessible, removable grate.

Height of Gully Riser

The minimum height of the gully riser from the top of the water seal to the floor surface must comply with Table DF6.10.2. The maximum height must not exceed 600 mm.

Table DF6.10.2: Minimum Height of Floor Waste Gully Risers

Fixture connected	Minimum height from water seal to floor level (mm)	
	Waste pipe entry at 88.5°	Waste pipe entry at 45°
Shower	150	100
Bath (only one)	250	200
Clothes washing machine	300	250
Other waste fixtures	250	150

Maintenance of Water Seal

At least one *waste fixture* must be connected to any floor waste gully in order to maintain the water seal. For this reason, the minimum depth of water seal must be 65 mm or the values in DF6.4.1, whichever is more.

DF6.11 Inspection Openings

General

Inspection openings comprise:

- inspection branches or square *junctions*; or
- inspection chambers.

Location

Inspection openings must be provided:

- outside the *building* on each branch connecting one or more water closet pans;
- at intervals of not more than 30 m;
- downstream and upstream ends of any section of *drain* that passes under a *building*;
- where any new section of *drain* is connected to an existing *drain*; and
- at the connection to the public *sewer*.

Appropriate locations are illustrated in Figure DF6.11.2 (overleaf).

Figure DF6.11.2 – Location of Inspection Openings

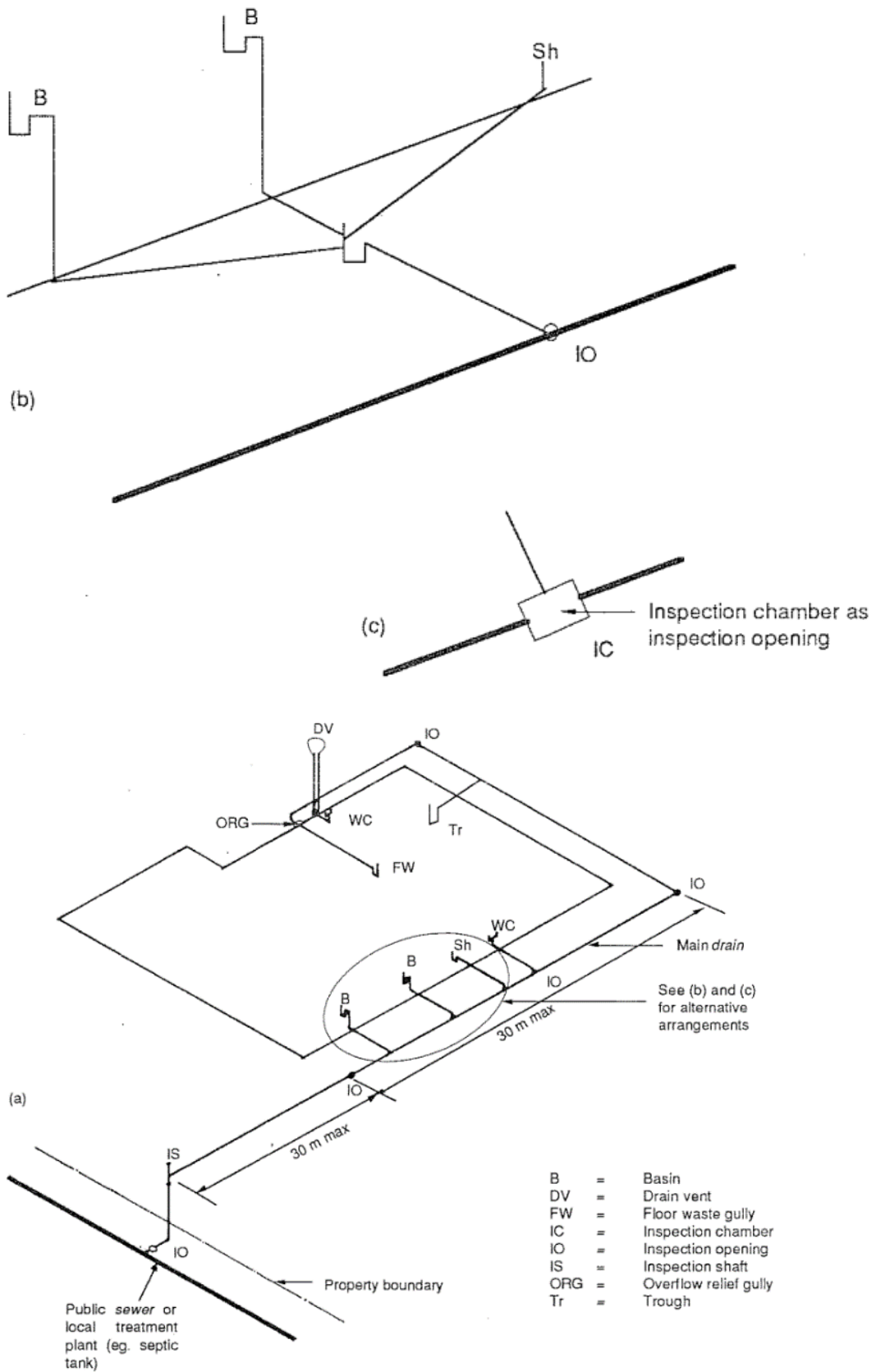

Size

- (a) The size of inspection branches or square junctions must be:
1. The same size as the drain for drains up to DN150; and
 2. Not less than DN150 for larger drains.

The dimensions of inspection chambers must comply with Table DF6.11.3.

Table DF 6.11.3: Size of Inspection Chambers

Minimum internal measurements (mm)			
Depth of floor to chamber	Rectangular		Circular
	Length	Width	Diameter
Less than 600	600	450	600
600 to 900	900	600	900
More than 900	1,200	750	1,050

Access for Inspection Branches and Square Junctions

Inspection branches and square *junctions* must be so located that it is possible to use them for inspection and for clearing obstructions in the associated sections of the *drain*. When located inside *buildings*, inspection branches and square *junctions* must have their openings readily accessible. Such openings must have airtight removable caps or plugs with gaskets, rubber rings or such other accessories to maintain tightness. When the caps or plugs are removed for inspection/maintenance, the gasket/rubber ring must be replaced with a new one.

Construction of Inspection Chambers

- (a) Where required:

An inspection chamber is *required* where an inspection branch or square *junction*:

- cannot accommodate all the convergent *drains*; or
- will not permit proper inspection or the clearing of obstructions.

- (b) Conduits and channels

The conduits in inspection chambers may be open channels of size and shape equal to the associated *drains*. The floor in inspection chambers must slope at a grade of between 1 in 10 and 1 in 15 towards the channel. Any formed *junction* must have a center line radius of not less than 300 mm. A fall of at least 30 mm must be provided in the invert of any channel that curves through 45° or more.

- (c) Access opening

A circular or rectangular access opening of 530 mm minimum dimension and fitted with a removable watertight cover must be provided at surface level. The cover must have been designed and installed to take any likely load on it. Where the size of the inspection chamber is larger than the size of the access opening, the top section of the chamber may be suitably tapered. Where this is done the full dimensions of the chamber must be maintained for a height from the chamber floor of at least 1.5 m, and the depth of the narrower *shaft* at the top does not exceed 350 mm. The minimum dimension of the *shaft* except at the opening must be 600 mm.

- (d) Access ladder

Where the depth of the chamber exceeds 1.2 m, rungs or rung ladders must be provided to AS 1657.

- (e) Materials of construction

Inspection chambers must have base and walls of a minimum thickness of 150 mm and constructed of:

- base – concrete; and
- walls – concrete or fully grouted concrete block masonry.

The concrete must be of 20 MPa grade. The walls and base must be suitably reinforced if *required*. The channels may be formed of half sections of pipes and fittings. Any access rungs or ladder must be of

galvanized steel. The cover and any frame to seal it must be of reinforced concrete or cast iron with safe lifting devices.

The walls and base of any inspection chamber must be cement rendered to a smooth finish. The render may contain a suitable waterproofing agent to ensure a waterproof finish. Where there is any likelihood of seepage of subsoil water into the manhole, the external surfaces of the wall must be plastered to a waterproof finish or a suitable water proofing agent added to the concrete in the walls and base.

(f) Inserts

The contact area between pipes or fittings and the walls formed around them, as well as holes broken into or formed in the walls of inspection chambers for insertion of pipes or fittings must be made watertight by:

1. the application of a suitable bonding agent around the pipes;
2. caulking the annular space between the wall and the pipe or fitting with a stiff mix of 1 part cement and 2 parts sand;
3. sealing with an epoxy based or other suitable sealant; or
4. a combination of these methods.

Junctions

(a) Junctions of drains must:

1. be swept in the direction of flow or have an oblique *junction* fitting with an upstream angle of no more than 60°;
2. not be *Y junctions* in the horizontal plane; and
3. where unequal *junctions* are used have the soffit of the branch in level with or higher than the soffit of the larger size.

(b) Square junctions in drains must only be used:

1. at the connection of an inspection shaft to a graded drain;
2. as the inlet riser of a gully or a floor waste gully;
3. as an inspection opening; or
4. at the top of a drop junction in place of a bend and inspection opening.

DF7 Sanitary Disposal

DF7.1 Specific Requirements

Sanitation facilities must ensure:

- (a) no discharge of wastewater of any kind to surface water;
- (b) no discharge to a soil surface that is:
 1. less than 1.5 m above maximum groundwater level; or
 2. less than 15 m from a downstream (coastward) drinking groundwater source for soakaway trenches systems (distance increases to 30 m for dry sanitary systems in Specifications DF7.1A or for soakaway pits in Specifications DF7.1B);
- (c) site inspection by an *appropriately qualified person* and standard special designs if system is with 15 m from a downstream (coastward) drinking groundwater source and less than 1.5 m above maximum groundwater level;
- (d) the maximum design loading to a soil surface does not exceed:
 1. 50 mm per day for septic tank effluent; and
 2. 70 mm per day for secondary or better treated effluent;
- (e) the effluent distribution system achieves a uniform application at or less than the maximum design loading rate; and
- (f) the system chosen is in accordance with Specifications DF7.1A and DF7.1B.

DF7.2 Means of Compliance

The requirements of DF7.1 are satisfied if all sanitary disposal works are carried out to the relevant provisions of:

- AS/NZS 1546.1 Part 1 On-Site Domestic Wastewater Management Units (Septic Tanks)

- AS/NZS 1547:2012 On-Site Domestic Wastewater Management
- AS/NZS 3500 Part 2 Sanitary plumbing and drainage and its amendments

DF8 Roof Drainage

DF8.1 Design of Roof Gutters

Roof gutters, where provided, must be sized on the basis of the rainfall intensity using Specification NF8.2. Eaves gutters must be sized for a rainfall intensity corresponding to a 20-year return period whereas internal box and valley gutters must be sized to a 100-year return period intensity as figure DF8.1 below. For temporary structures, it is enough if all gutters are sized for a 5-year return intensity. The Vanuatu Meteorology and Geo-hazards Department may be contacted to supply 100-year, 20-year, and 5-year return period intensities in mm/hr of rainfall for representative areas in the country.

Further information on roof drainage can be found in the AS/NZS 3500 Part 3 – Stormwater Drainage.

Figure DF8.1: Gutter Sizes and Rainfall Intensity

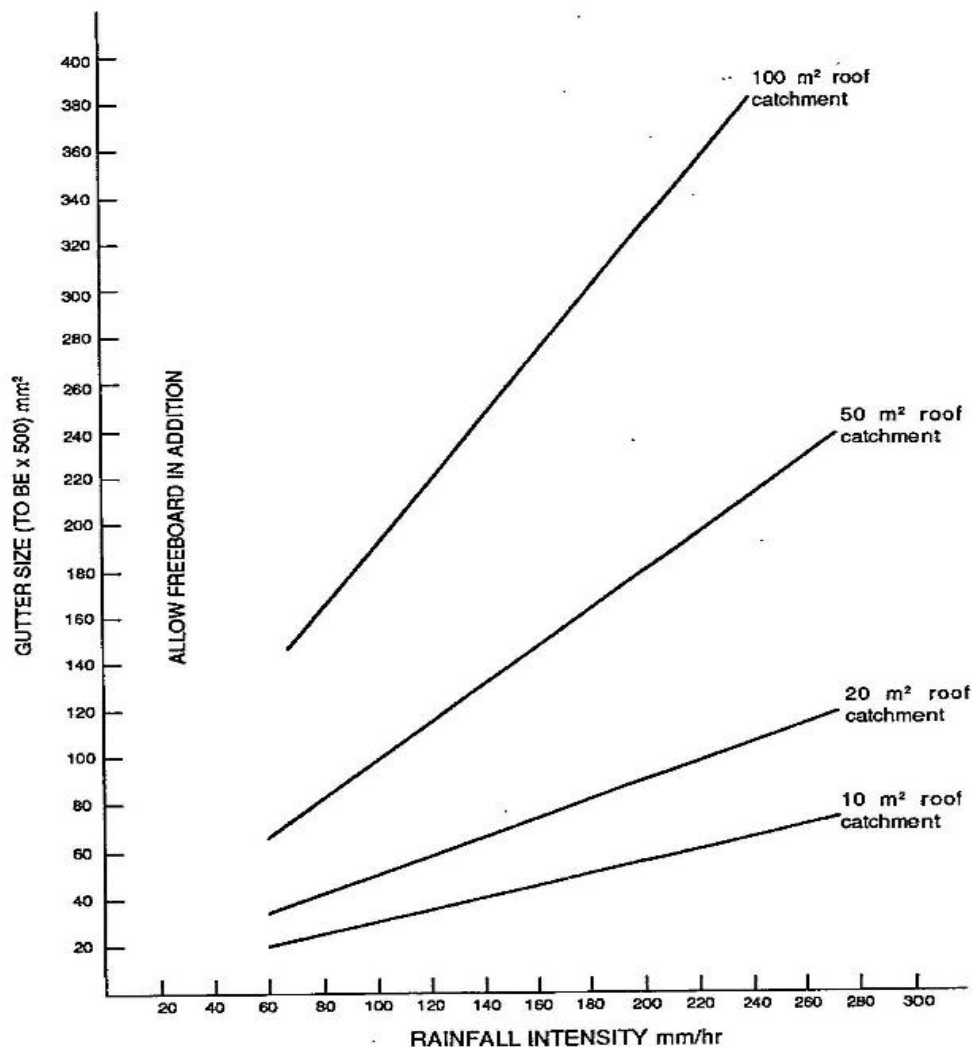

Notes:

1. The roof catchment area is the area of the roof drained by one downpipe. It is taken as the area of the roof from ridge to gutter between two adjacent downpipes.
2. Values can be interpolated for catchment areas falling between the give figures.
3. The gutter sizes do not include any allowance for freeboard. A freeboard of 25 mm for eaves gutters and 35 mm for internal box gutters must be added to the cross-sections derived from

the table.

Gutters must have a minimum slope of:

1. 1 in 500 for eaves gutters; and
2. 1 in 200 for internal box gutters.

These slopes must be increased where there is any material risk of clogging of the gutters and downpipes with leaves and other such matter.

Note:

With high fronted eaves with fascia boards, there could be overflow from the back of the gutter into the *building* if the downpipes or gutters are blocked. One method of preventing such overflow is by providing drainage slots along the front of the gutter at a level lower than the back edge. Another method would be to provide sumps and weirs at the ends of the gutter or where the downpipes take off. The risk of overflow into the *building* from any internal box gutter can be reduced by providing sumps and weirs at the ends of the gutter.

DF8.2 Design of downpipes

The minimum area of cross-section of a downpipe must be the greater of:

- (a) half the area of cross-section of the gutter it serves; or
- (b) the area calculated for each 10 m² of the roof area drained by it at the rate of:
 1. 650 mm² for eaves gutters; and
 2. 930 mm² for internal box gutters.

DF8.3 Incompatible Metals for Gutters

Direct contact between the following metals must be avoided in order to prevent corrosion:

Zinc or aluminium and alloys of either	and	copper or copper alloys and some grades of stainless steel
--	-----	--

Care must be taken to avoid bimetallic corrosion occurring in the guttering and storage tanks.

DF8.4 Rainwater Storage

Rainwater collection from the roof depends on several factors. Unless these are suitably matched, the supply will not be satisfactory. The factors are:

1. the average annual rainfall and its variability through the year;
2. the roofing material and the available area of the roof;
3. the daily rate of consumption of water;
4. the storage volume and the material of the tank; and
5. the desired reliability of the supply.

Relationship of rainfall, variability, roof area and storage volume

The higher the average annual rainfall, the smaller the collection area of roof required for a given rate of consumption. In order to allow for variation in actual rainfall from the monthly averages, it is advisable to have the available roof area to be twice the theoretical area.

If the pattern of rainfall is fairly uniform through the year, the size of storage tank for a given rate of consumption would be relatively smaller. The tank size could be as small as to hold 50 days consumption where rainfall is quite uniform through the year. Where most (such as 75%) of the annual rainfall occurs in 3 or 4 months, it will be necessary to size the tank to hold 100 to 120 days of consumption. This assumes that the available roof collection area is twice the theoretical area. Where the available roof area is less than about 1.4 times the theoretical area, the required storage volume tends to increase very steeply. The size of the tank determined from these considerations should normally give an average reliability of supply with a failure rate of about once every 5 years. If an average chance of failure of supply of once a year is acceptable, the calculated tank size can be reduced by about 30% in areas of high rainfall and by 40% in areas of lower rainfall.

Design

The quality of the water in the tank is contingent on managing potential contamination routes by implementing the following performance criteria:

- (a) location minimizes the accumulation of leaves on the roof reducing the potential growth of micro-organisms;
- (b) installation of a regularly cleaned fly wire screen on the inlet to the tank reduces debris and the breeding of mosquitos; and
- (c) installation of a first flush system diverts any chemical and biological debris collected on the roof away from the storage tank.

Owners may opt for an automatic first flush system, appropriately sized based on roof area and anticipated pollutant load.

Covered water tanks will prevent direct ashfall and other types of contamination.

The inclusion of other gutter accessories such as leaf diverters is optional but may help minimize debris entering rainwater storage tanks and improve the water quality if regularly cleaned.

The theoretical relationship for calculating the roof area acting as the catchment can be expressed as:

$$A = 365 \times C/R, \text{ where}$$

- (a) A is the roof area acting as the catchment in square meters;
- (b) C, the daily average consumption of water by the household in liters; and
- (c) R, the average annual rainfall in millimeters.

However, for the reasons stated in sPart DF 9.2, the practical value of the roof catchment is:

$$A = 2 \times 365 \times C/R = 730 C/R$$

In order to assess the size of the storage tanks Vanuatu has been divided into 2 categories:

1. areas with a more uniform spread of rainfall, and
2. those with rainfall concentrated over 3 or 4 months of the year.

In the case of the areas with a more uniform rainfall, it is estimated that a storage capacity of 50 days consumption would be adequate to provide a reasonably reliable supply with the risk of failure of only once in 5 years. For a similar level of reliability in areas with an uneven spread rainfall, the estimated storage is equal to 80 days consumption.

Table 8.4.1 can be used to estimate the minimum roof area and storage capacity required in representative regions in Vanuatu, for a family size of 5 members, each consuming no more than 30 liters per day of the stored water. An example is provided below for a different family size and/or daily consumption.

Table 8.4.1: Minimum Roof Area and Tank Capacity for Rainwater Collection

Total tank capacity of 7.5 kiloliters		Total tank capacity of 12 kiloliters
Minimum roof catchment to drain into storage (m ²)		
50	30	80
SHEFA SANMA MALAMPA PENAMA	TORBA	TAFEA
<p>Note 1: This table is based on a family size of five members, each consuming no more than 30 liters per day of the stored water. The minimum roof area and storage capacity required in representative regions in Vanuatu have been calculated for the average rainfall in those regions.</p> <p>Note 2: If a risk of failure of supply once a year is acceptable, the tank size can be reduced by 30%.</p> <p>Example: If the family size considered is one in which TAFEA is 7 and the daily consumption per head is 20 liters, then:</p> <p>(a) the required roof catchment = $80 \times 20 \times 7 / (30 \times 5) = 75$ square meter</p> <p>(b) tank size = $12 \times 20 \times 7 / (30 \times 5) = 11.2$ kiloliters.</p>		

Effect of roofing material and the environment

Rainwater in general is very pure; hence many metals dissolve in it much faster than in land-based water. For instance, if any lead is used in the roof for flashing or in the form of lead-based paint, the rainwater would leach the lead into the storage tank. If this happened, the water would not be potable. The nature of materials used in the roof must be ascertained and their safety confirmed before a decision is taken to use the runoff from the roof. In general, galvanized iron sheets, zinc-aluminium (Colorbond) coated sheets, and several other products are safe.

As far as possible, leaves and twigs must not be allowed to fall on the roof. The leached extracts from some leaves would make the water unfit for consumption. In addition, the organic matter from leaves and twigs would encourage the growth of micro-organisms in the tank, thereby polluting the water. Accumulation of any dust on the roof, such as from industrial activity nearby would also make the water unfit.

To help prevent organic materials from entering the storage tank or mosquitoes breeding in the tank, water tanks must have an inlet screen. A helpful tip is to place a layer of mosquito netting on top of the inlet screen to help filter out any incoming debris. Stainless steel mosquito netting will be more durable, compared with fiberglass and plastic netting. Further improvements can be made to water quality by installing a PVC Leaf Beater and First Flush Diverter. The tank design can also be modified so that the tank outlet is elevated to 200 mm from the floor so that there is less chance that sediments will flow out through the tap.

Regular maintenance of the rainwater storage system is recommended including cleaning debris from the roof and gutters, cleaning of the tank inlet screen, flushing out the tank to remove accumulated debris and repairs to the guttering and tank outlet tap.

Tank material

Tanks are generally made of polyethylene (rotomolded), galvanized or zinc-aluminium-coated steel plates and sometimes of fibreglass. Whereas suitable fibreglass would be inert and therefore not affected by the rainwater, galvanized steel could. The greater the purity of the stored water, the greater the risk of the galvanizing getting leached out very fast. If the roofing sheets are of galvanized steel, the stored water would already contain some of the zinc from the roofing material and hence the tank would

last longer. This is not the case where the roofing is of zinc-aluminium-coated or -painted steel or of some other man-made material.

In order to prevent the corrosive effects of pure water on the tank coating, suitably formulated metaphosphates are commercially available. These produce a protective film inside the tank and thus extend the life of metal-coated tanks. Such methods must be used from the very first filling of the tank. There are also plastic protective coatings compatible with potability which are applied to metal tanks. The inside of the tank must not be painted with any ordinary paint.

In no case must lead be used in any form such as in sheets for flashing or as paint, etc. on roofs from which water is collected.

For aluminium tanks installed on timber tank stands, do not cover the timber decking with galvanized flat iron as this will create an ideal environment for bimetallic corrosion to occur when water is trapped between the two different metal surfaces. Covering the timber decking with corrugated iron would be the preferred option as the corrugations will effectively prevent water sitting between the total metal surfaces.

Erection of rainwater tanks

It is best to erect the tank in a shady location but away from falling leaves that could clog the strainer, and, in the case of translucent material like fibreglass, have a dark colour to exclude light. Organic growth could develop on the sides of tanks in the presence of light and warmth. When the tank is part empty, the organic growth would decay and give off gases, discolour the water, and produce corrosive acids. The absorption of the gases and acids could also give the water an unpleasant flavor.

The overflow pipes fitted to tanks for the disposal of excess inflow of rainwater must be adequate to prevent uncontrolled overflow. Such pipes must not terminate very close to storm water drains and soak pits as otherwise unpleasant gases might enter the tank. The pipe end and all opening to the tanks must be fitted with strong, durable mesh to prevent birds, mosquitoes and other insects entering the tank.

No copper pipe should be used with any metal water tank. The inlet pipe must discharge the water through a durable strainer fitted well above the high-water level. The inlet must not be close to the tank wall. Where tanks are interconnected, each tank must receive at least some of the water directly from the roof. No tank must get its supply entirely from other tanks. It is convenient to have individual domestic tanks of no greater capacity than 4 or 5 kiloliters (1,000 gallons).

Ensure the stand is properly designed so that it can hold the weight of a full tank. Tank stands can be with reinforced concrete, timber frame, or galvanized posts with timber bearers decking. For timber tank stands, inclusion of diagonal bracing is recommended to improve earthquake resistance. In cyclone-prone areas, tanks should be tie down to the tank stand to prevent from being dislodged.

Maintenance considerations

Pre-emptive maintenance must be done on an annual basis to avoid any water contamination, including cleaning the roof, gutters and the tank.

The quality of the water in the tank is increased by implementing the following performance criteria:

1. routinely emptying of a first flush system installed to divert any chemical and biological debris collected on the roof away from the storage tank;
2. routinely cleaning of the sludge out from the bottom of the tank either manually or through the fitting of an automatic vacuum valve; and
3. where possible, bulk dosing the tank with chlorine tablets from time to time to remove resident pathogens.

SPECIFICATION DF7.1

Sanitary Systems

Contents

A. Dry Sanitary Systems For Areas Where There Is No Piped Water Supply.....	30
1. Scope.....	30
2. Principles of safe on-site dry sanitation systems.....	Error! Bookmark not defined.
3 Location.....	30
4. Types of dry latrines.....	30
4.1 Dry ventilated improved pit latrines.....	30
4.2 Composting Latrines.....	32
B. Sanitary Systems where there is Piped Water Supply.....	34
1. Scope.....	34
2. Principles of safe on-site wet sanitation systems.....	Error! Bookmark not defined.
3. Location.....	34
4. Types of wet latrines.....	35
4.1 Wet pit latrines.....	35
4.2 Septic tanks.....	37
4.2.1 Function of a septic tank.....	37
4.2.2 Construction.....	37
4.2.3 Design details.....	37
4.2.4. Effluent absorption area.....	43
4.2.5 Soakaway systems.....	43
4.2.6 Desludging.....	46
4.2.7. Grease traps.....	46
4.3 Tailored treatment packages.....	48

A. Dry Sanitary Systems for Areas Where There Is No Piped Water Supply

1. Scope

This Annexure sets out the requirements in relation to the location and types of latrines in area where there is no piped water supply.

This section should be read in conjunction with guidance the Vanuatu Sanitation and Hygiene guidelines (MoH [website](#), 2023).

2. Principles of Safe On-site Dry Sanitation Systems

Refer to performance requirements.

3. Location

The latrines must be screened from public view, always be accessible to all users, and be located not less than:

- (a) 30 m from any well or other similar potable ground source of water (not applicable for composting latrines);
- (b) 1.5 m above maximum groundwater level;
- (c) 6 m from the front or street boundary of the allotment;
- (d) 3 m from any boundary other than the front or street boundary; and
- (e) 3 m from any dwelling within or outside the allotment.

Latrine pits located within 30 m of drinking water source or marine and river environment shall be sealed with cement mortar, polyethylene or similar liner to avoid soakage of effluent to marine and river waters. Composting latrines described in Section 4.2 comply with this requirement.

4. Types of Dry Latrines

There are two recommended types of dry on-site sanitary systems: dry ventilated improved pit latrines and composting latrines (Figures 4.1 and 4.2). No simple pit latrines are allowed.

Note: VIP Toilets are not permitted in Luganville Municipal Council Area as per LMC "Prohibition of pit-Latrine Facilities and Septic Tank Discharge Control Bye-Law No 22 of 2021" under Municipalities Act.

4.1 Dry ventilated improved pit latrines

Function and operation of a VIP latrine

Dry pit latrines have no flushing facility (Figure 4.1). They are manually dug pits or mechanically bored holes a few meters deep over which a squatting plate with a bung seal or seat with lid is placed. Gases generated, such as methane, are vented through a tall vent pipe. When pits are dry, a combination of anaerobic and aerobic decomposition takes place. When a pit is almost full, the surface cover is removed and the top of the pit filled with a mixture of lime and earth. A new pit is then dug.

In addition to the section 3, the latrines must be located preferably at a lower ground than where a potable source of water is located so that the prevailing wind around the latrine is not shaded.

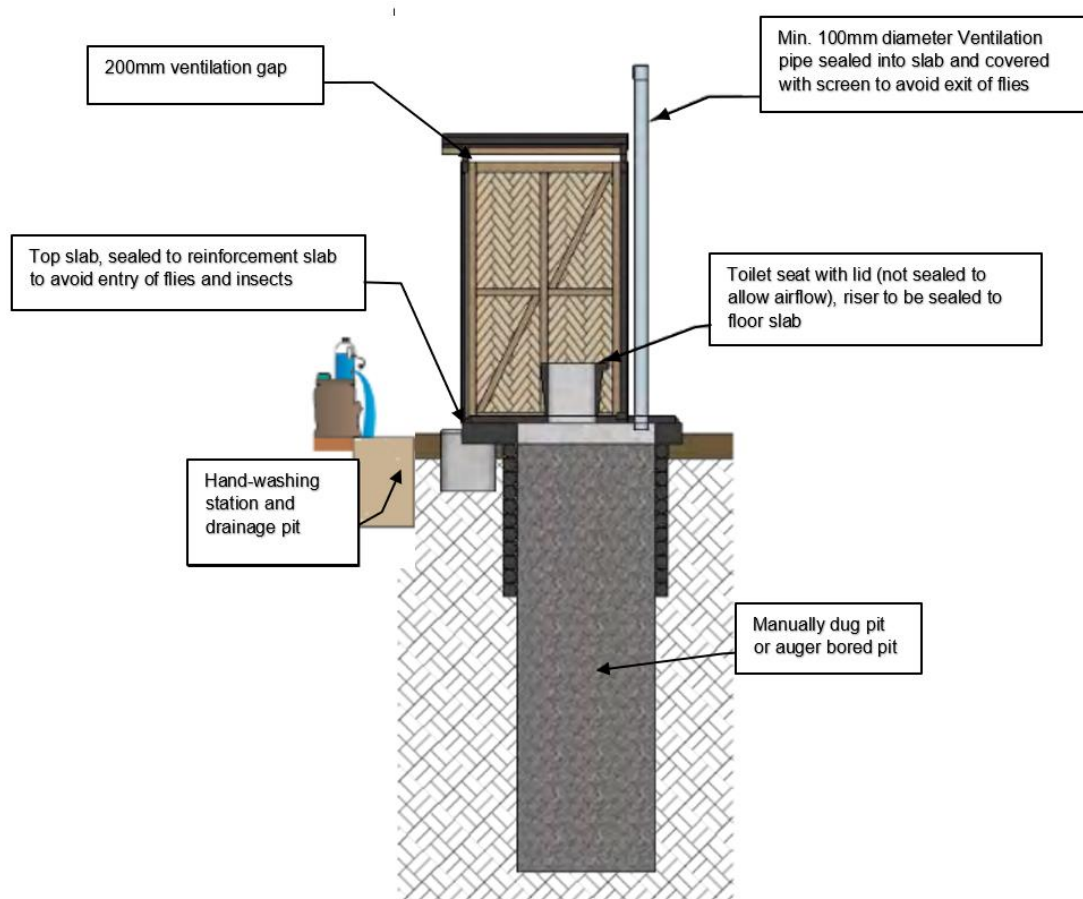

Figure 4.1: Standard Ventilated Improved Pit (VIP)

Calculation of dimensions

The pit volume depends on the number of users, the period for which it is used and a freeboard allowance of 0.5 m depth. If the pit remains dry the annual accumulation of sludge is about 0.08 m³/person. In wet pit latrines or where washing water is allowed to enter it, the accumulation rate could be taken as 0.05 m³.

For example, for a family of 5 which plans to use the pit for 5 years, the volume *required* to hold the sludge would be:

1. for a dry pit: $5 \times 0.08 \times 5 = 2.0$ m³;
2. for a pit area of 0.6 m x 1.0 m, the depth required for the sludge = $2.0 / (0.6 \times 1.0) = 3.3$ m;
3. add freeboard allowance = 0.5 m;
4. total depth required = 3.8 m.

Note that reinforcements should be considered for pits depth deeper than 2 m.

Dimension of a typical cover slab

A pedestal type of cover slab which a user can sit on is the preferred type in Vanuatu.

The cover slab must be placed over the foundation so that it is fully supported without any gaps. Cement mortar may be used to firmly seat the slab over the foundation. The finished surface of the slab must be at least 150 mm above the immediate surrounds.

Vent pipe

A 100 mm PVC vent pipe may be erected over the pit to remove foul gases generated by the decomposition of the waste matter. The vent pipe should be painted black and face north to maximize the solar heating effect on the pipe and promote updraft. The squat slab has a matching PVC insert on which the vent pipe can be erected. The vent pipe must be supported to the frame of the shed over the pit. The vent pipe must be at least 2.5 m high and 500 mm above the roof at the point of penetration or

the nearest point. The open end of the vent must be covered with durable fly screen to prevent flies and mosquitoes from entering the pit.

A folding lid can be used to keep it covered when it is not in use.

Maintenance

The pit latrine must be kept clean at all times. However, do not use strong disinfectants in large quantities. It is best to use a wet mop or wet rag soaked in diluted disinfectant or cleaning agent to clean the cover slab and seat. If chemicals and cleaning agents are allowed inside the pit, they would drastically affect the bacterial degradation of the waste matter and there could be problems with foul smells and the pit could be filled sooner.

Any erosion of the fill around the foundation must be noted and repaired. The fly screen cover over the vent pipe must also be checked periodically and replaced promptly if damaged. The shed over the pit must be kept in good repair.

Pit closure / decommissioning

When the pit is full to within about 0.5 m of the cover slab, it must not be used any more. Another pit must be located at least 3 m away (the deeper the pit, the greater the separation distance). The cover slab, vent pipe, and shed can be reused over the new pit.

The remaining space in the old pit must be filled with earth. It is good to overfill and form a mound so that enough surplus earth is available when the material subsides with decomposition. The pit can be dug out after a minimum period of 1 year and the material safely used as a fertilizer.

4.2 Composting latrines

Composting latrines (Fig 4.2a and b) are an alternative to dry pit latrines in areas of challenging environments (coastal areas, high groundwater, frequent flooding, hard rock, dense habitat). The recommended type is the twin-vault batch systems. One vault at a time receives excreta. Urine is drained away in a separate surface channel. The excreta are covered with loose earth, ashes, or sawdust to reduce odors. When the vault is nearly full, it is sealed with lime mortar and left for a few months to compost by anaerobic bacterial action. Contents are then removed and used for fertilizer. During this time the other vault is used as the latrine. This type of latrine works well in warm climates and with little or no urine loading.

The vaults can be above ground or underground.

Figure 4.2(a): Above Ground Vaults Composting Latrines

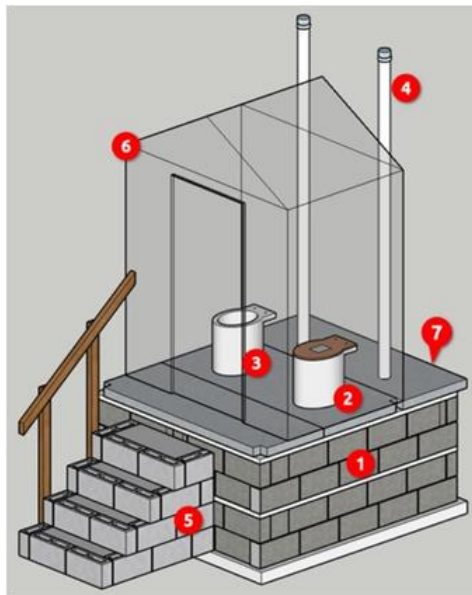

1. Composting Chambers
2. Chamber that is composting
3. Chamber for use
4. Vent pipe for each chamber
5. Access stairs or ramp
6. Toilet house with door and window
7. Chamber access panels.

Figure 4.2(b): Underground Vaults Composting Latrines

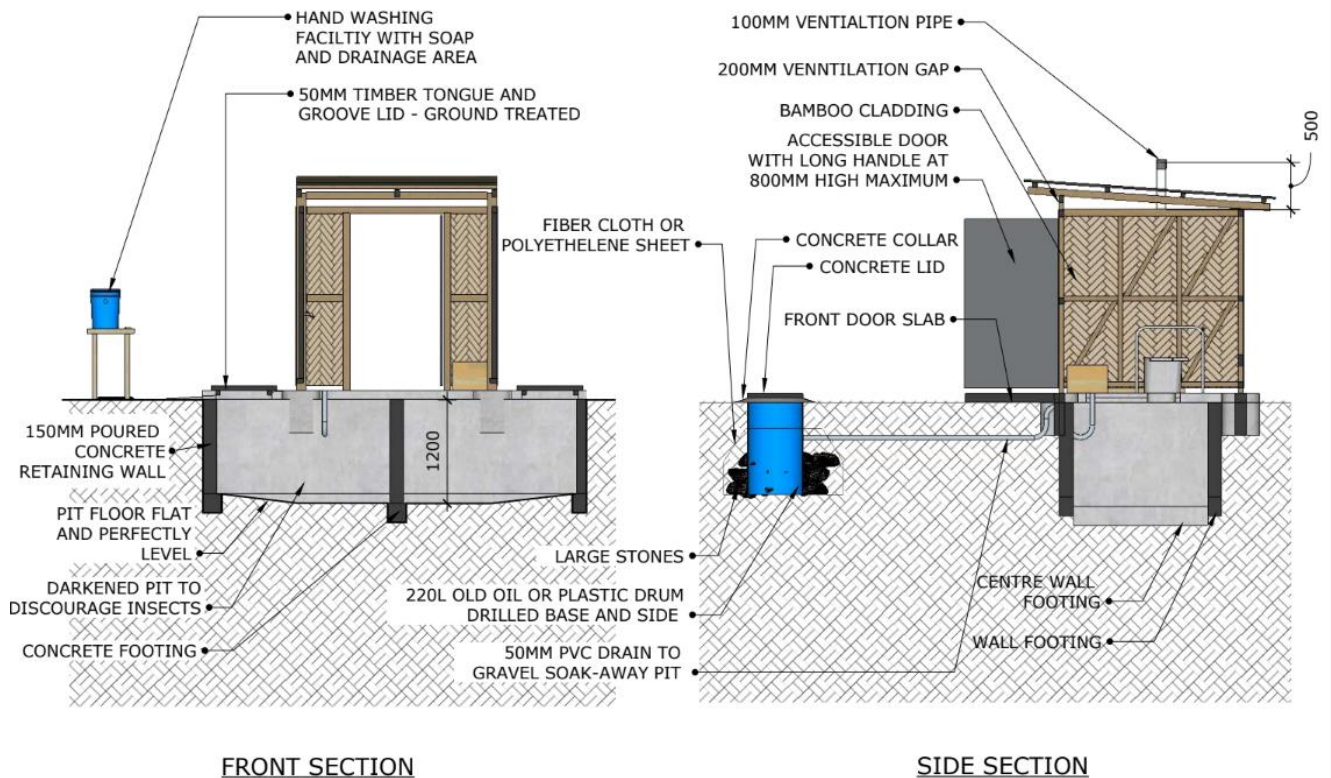

B. Sanitary Systems where there Is Piped Water Supply

1. Scope

This specification sets out the requirements in relation to the location and types of latrines in area where there is piped water supply.

This specification also applies to both Sections DF and NF.

This section should be read in conjunction with guidance the Vanuatu Sanitation and Hygiene guidelines (MoH [website](#), 2023).

2. Principles of Safe On-site Wet Sanitation Systems

Refer to performance requirements.

3. Location

Wet pits, septic tanks, and other connected works such as absorption trenches and soak pits must be located at a sufficient distance to prevent contamination of potable water sources and nuisance. Figure 3 shows typical layouts with the minimum separation distances marked on them. It will be seen that a minimum distance to potable water sources shall be:

- (a) 15 m in the case of absorption trenches; and
- (b) 30 m in the case of a soak pit.

The toilet house should also be *accessible* to all users at all times.

Another important consideration in the siting of a septic tank is that an adequately absorbent area must be available for discharging the effluent through absorption trenches or soak pits.

While soil absorption systems are effective in the attenuation of pathogens within the setback distances detailed above, they are generally not effective in the attenuation of nutrients, primarily nitrogen. Where the nutrients pose a major environmental health risk, there is a need to consider other treatment options to be designed by a *professional consultant*, as described in section 4.3 of this Specification.

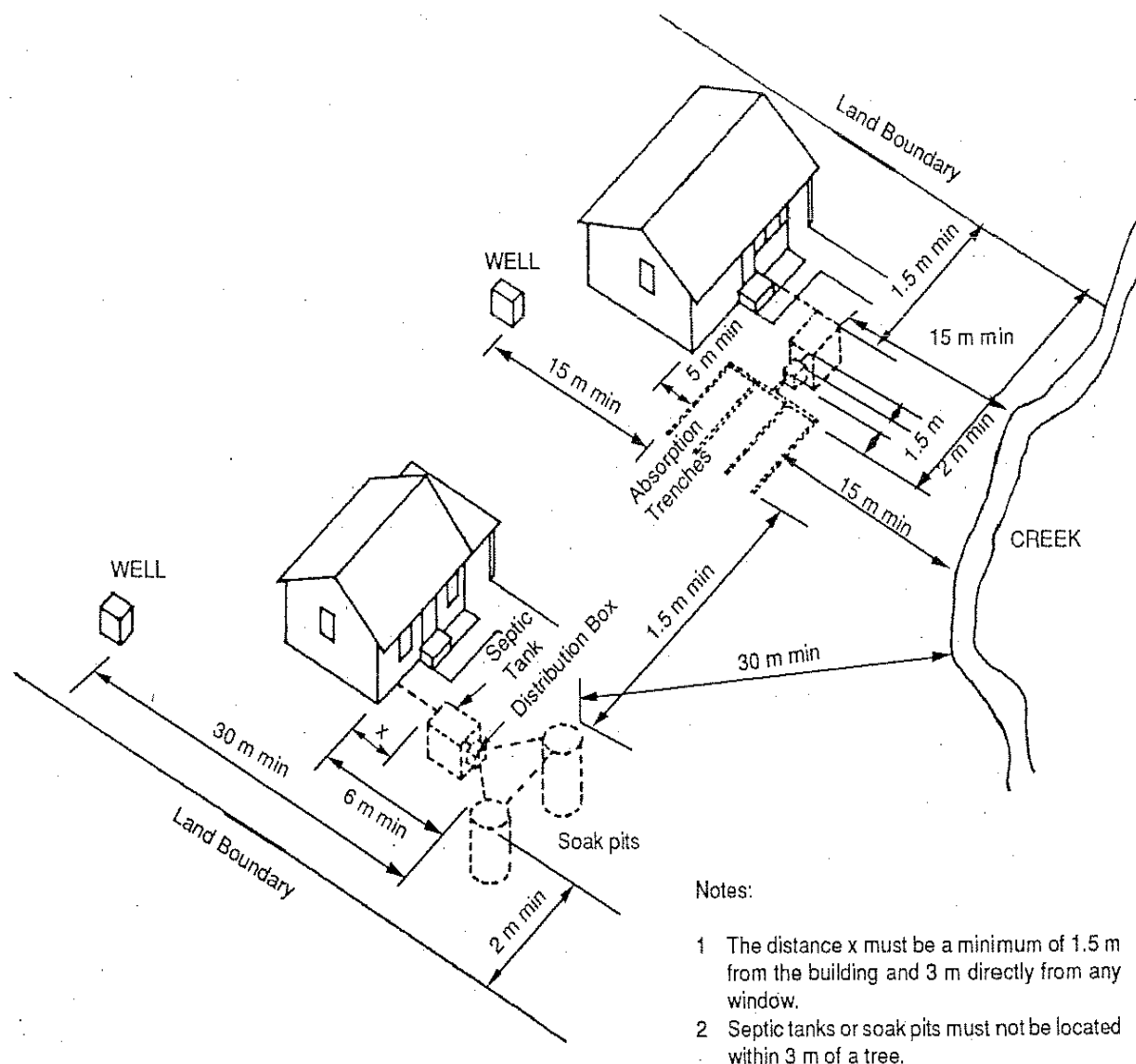

Figure 3: Typical Location of Septic Tank Systems with Minimum Required Separation Distances

4. Types of Wet Latrines

There are three recommended types of Wet on-site treatment: wet pit latrines, septic tanks, and tailored package systems.

4.1 Wet pit latrines

The use of wet pit latrines is recommended, when there is no access to sewage trucks to ensure the required emptying services.

Wet pit latrines are bucket-flushed, water-seal, floor-pan latrines with a soakaway pit in porous soil. Digestion of excreta is by anaerobic bacteria below water level. The lower section of the pit is lined to retain water when the pit does not reach the water table. Gases from the digestion are vented through a tall pipe.

Where the pit penetrates through fissured rock or coral through which liquids from the pit might pass unfiltered, the advice of the Health Department must be sought on the location. Otherwise, all the fissures must be closed with concrete or cement mortar.

The *site* must be on firm ground which will not cave in or slump while digging the pit. If there is some problem in this regard, one solution could be to line the affected area with an old drum with both ends removed. The *site* should not be subject to *flooding* or remain waterlogged.

The recommended type of wet pit latrine is with two offset pits as shown in Figures 4.1a and 4.1b.

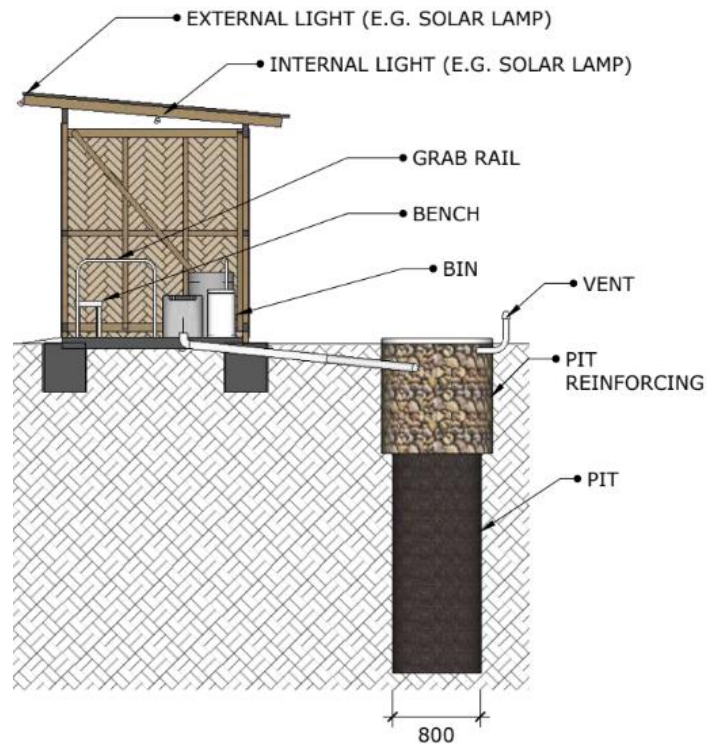

Figure 4.1a Wet Pit Latrines

Further details about the twin-pits arrangements are provided in Figure 4.1b.

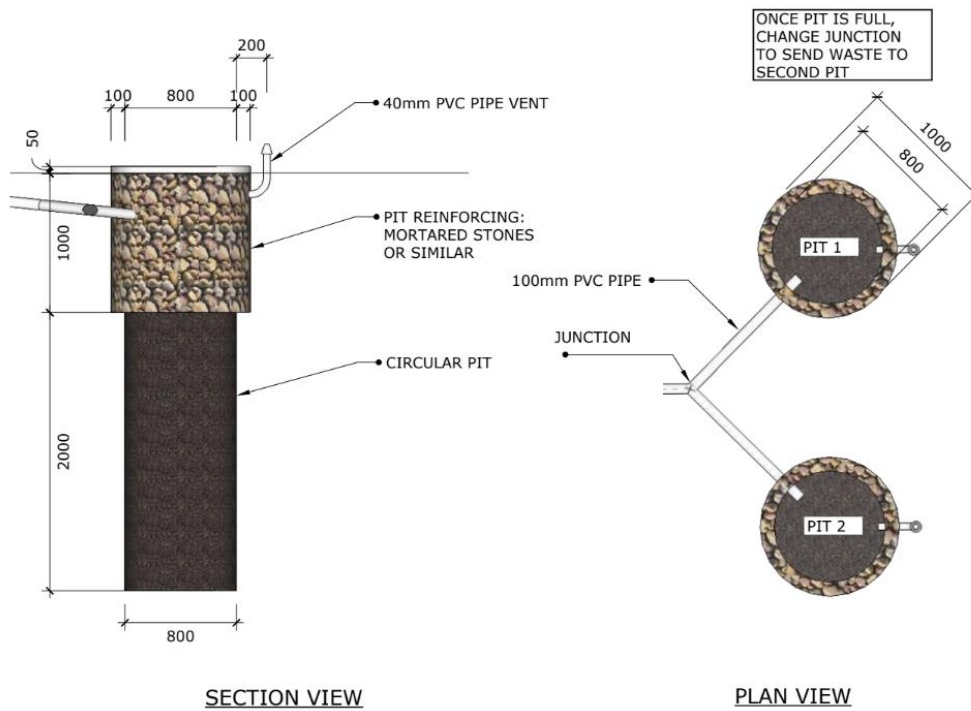

Figure 4.1b Twin Pit Arrangements

4.2 Septic tanks

The use of septic tanks is not recommended when there is no access to sewage trucks to ensure the required emptying services.

4.2.1 Function of a septic tank

The basic function of a household septic tank is to receive normal liquid household wastes and to condition them for such a time, and in such a manner, that the clarified effluent may be percolated efficiently into the subsoil, where it is absorbed and evaporated. In order to perform this basic function, all septic tanks must fulfill the following requirements:

(a) Remove solids.

A septic tank must have a primary or liquefying chamber of such shape and size that the rate flow of all sewage is so reduced that at least the larger solids sink to the bottom and are retained, and the clarified effluent is discharged. The inlet and outlet pipe of this primary chamber must be so shaped and located that the scum which forms on the surface of the sewage is not disturbed. The capacity of the tank is usually kept equal to the inflow for 24 hours to allow a day's retention.

(b) Promote bacterial action.

To ensure that the solids and liquids in the tank will decompose, it is necessary that the tank be designed so that either:

1. anaerobic bacteria, which thrive in the absence of free oxygen, are present; or
2. aerobic bacteria, which thrive with access to air, are also present.

(c) Store sludge.

A fine slit-like sludge accumulates at the base of the primary tank. It follows that the primary tank must be of sufficient size to store sludge for a considerable period; otherwise, if the tank is not cleaned out at frequent intervals, the sludge will eventually be scoured from the tank and clog the outlet drain and soakaway system.

4.2.2 Construction

Septic tanks may be of reinforced concrete or of reinforced block masonry walls over a reinforced concrete base. Tanks of precast concrete construction may be made from rectangular slabs which are assembled on the site, or be of cylindrical construction, either as a single cylinder open at the top, or a stack of short, open-ended cylinders.

Fibreglass septic tanks or rotomolded from high density polyethylene shall be permitted where they cater for households of up to 10 persons.

Whatever form of construction or materials are used for the sides and bottoms of septic tanks the resulting work must be impervious to water. For tanks of rectangular section, it is important that all internal angles be well-rounded, so as to minimize shrinkage cracking. Leakage at the corners of tanks of precast concrete construction made from rectangular slabs, or at the joints of precast tanks made from several open-ended cylinders, must be detected and corrected in advance.

Every septic tank of block masonry or concrete construction must be covered with reinforced concrete slabs and removable manhole covers fitted over every compartment. The manholes are used when it is necessary to pump out or otherwise clean the tanks. Inspection openings are also required over the inlet and outlet square *junctions*.

4.2.3 Design details

The design of the type of septic tank system will be governed by the results of the investigations of the *site* and locality, taken in conjunction with the results of the percolation test discussed in clauses 4.2.4. Due to its technical aspect, investigations and tests are not mandatory for individual houses covered under Section DF, but investigation and testing are required for Institutional *Buildings*, Resorts and Hospitals and Industrial systems covered under Section NF.

Septic tanks are designed to be emptied before the sludge fills to a level where the effluent retention time decreases below 24 hours. The timing of the emptying of the septic tank can be calculated based on the following AS 1547: 2012 design figures, the number of users and the size of the tank, all as Table 4.2.3 below

Table 4.2.3 Septic Tank Design Rates

AS/NZS 1547 (Design Rates)	All wastewater	Blackwater only
Wastewater flow rate (liters per capita per day)	150	50
Sludge accumulation rate (liters per capita per year)	80	50

It is recommended to separate blackwater and greywater treatments in order to minimize the size of septic tanks and associated soakaways. As a rule of thumb, allow 0.2 m³ per user for “blackwater only” septic tanks with a 6-year emptying frequency, noting that:

1. “blackwater only” septic tanks will be half the size of “all wastewater” septic tanks for the same emptying frequency;
2. “blackwater only” soakaways will be one third the area of an “all wastewater” soakaway for a given soil condition.

Impervious to water

Whatever forms of construction or materials are used for the sides and bottoms of septic tanks, the resulting work must be impervious to water. For tanks of rectangular section, it is important that all internal angles be well-rounded, so as to minimize shrinkage cracking. Provisions shall be made to prevent sealed septic tanks from floating in high water table areas when emptied.

Inlet and outlet

Every septic tank of block masonry or concrete construction must be covered with reinforced concrete slabs and removable manhole covers over the inlet and outlet square *junctions* for inspection and emptying. The inlet and the outlet pipes from every septic tank shall fitted with tee pieces and shall be at least DN 100 mm.

Figures 4.2.3a, 4.2.3b, and 4.2.3c and Tables 4.2.3a and 4.2.3b give details of the reinforcement *required* and dimension *required* of built-in-situ septic tanks. These figures and tables apply to both Sections DF and NF.

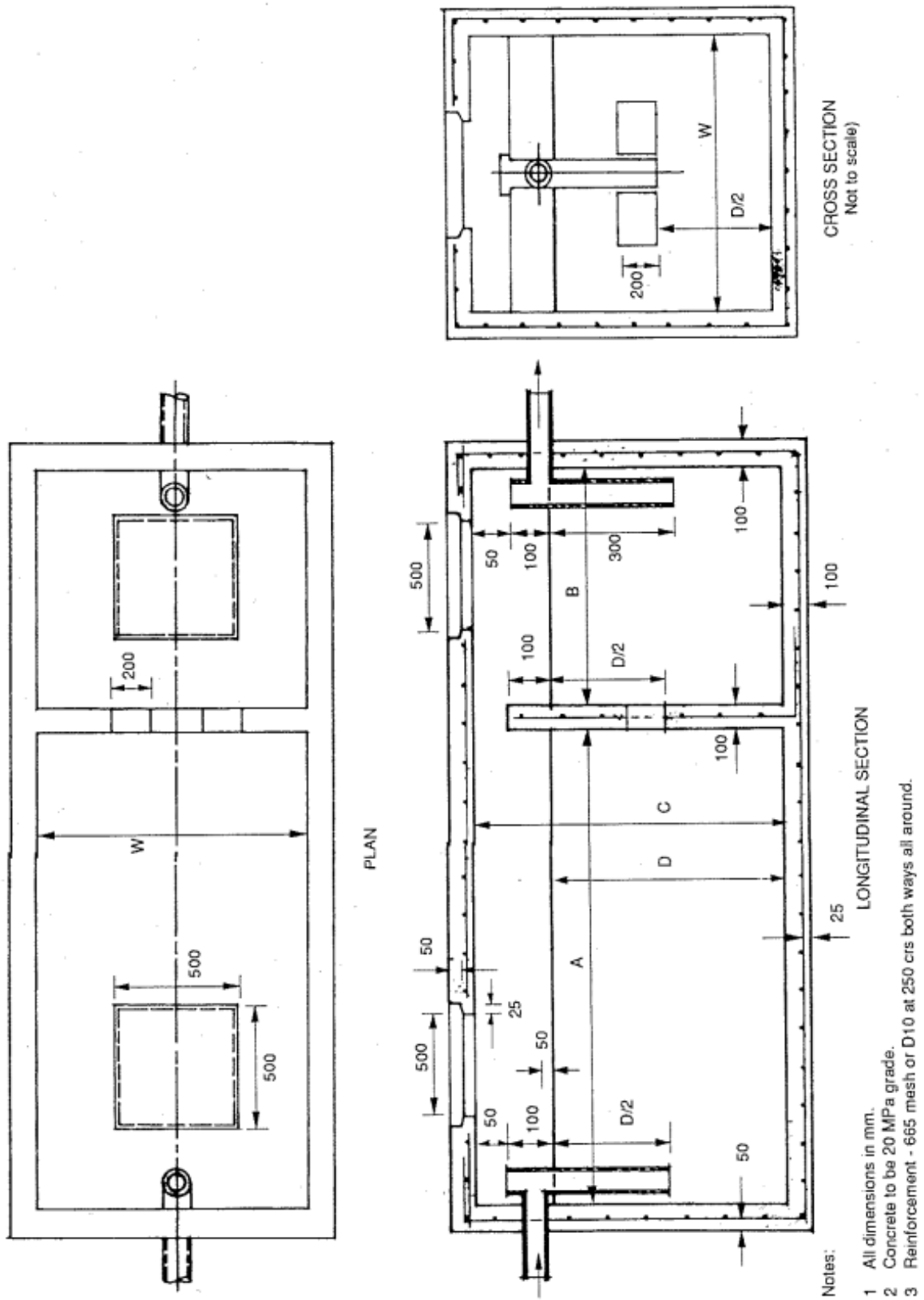

Figure 4.2.3a: Details of Reinforced Concrete Septic Tank

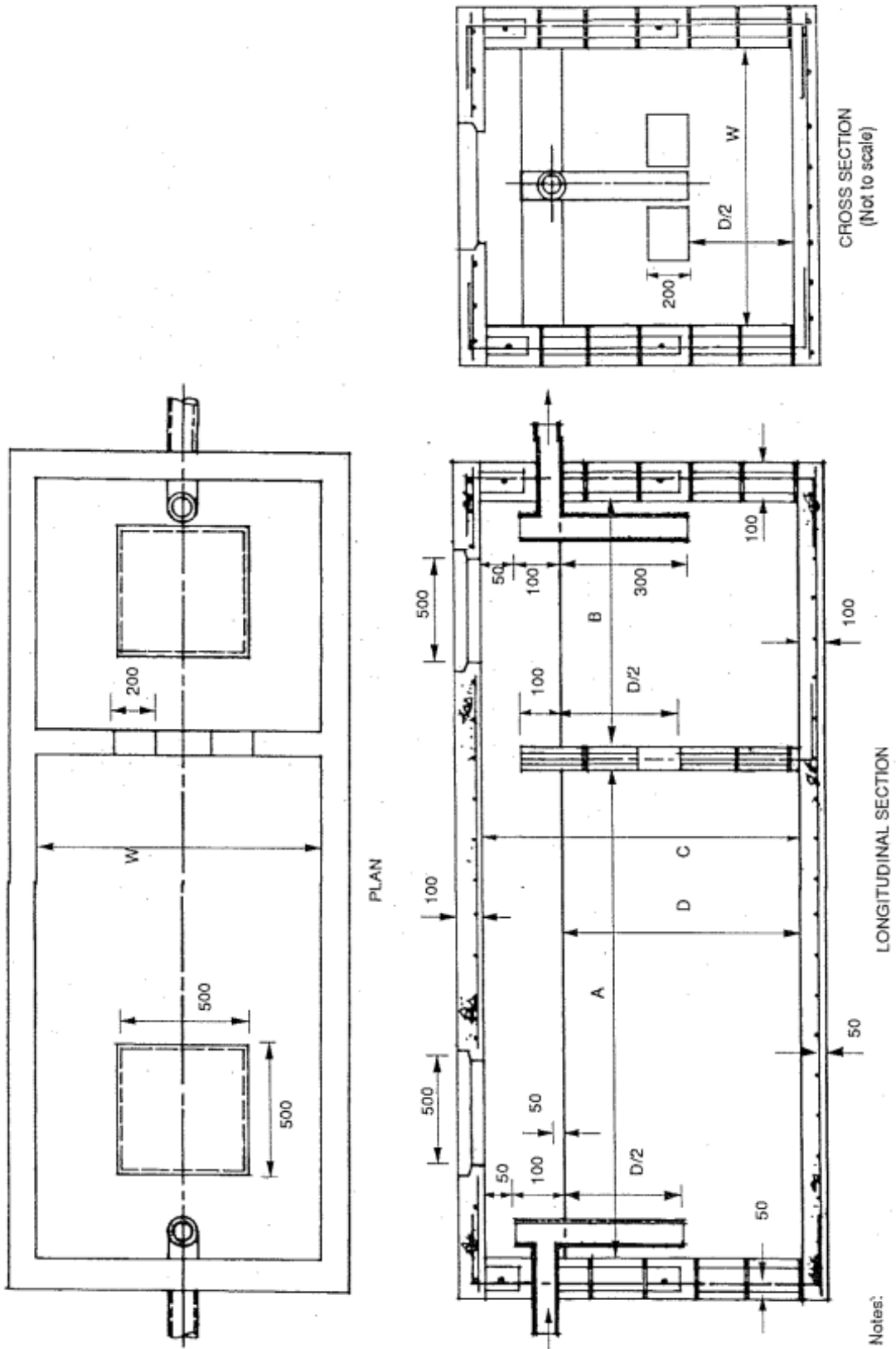

Figure 4.2.3b: Details of Reinforced Block Masonry Septic Tank

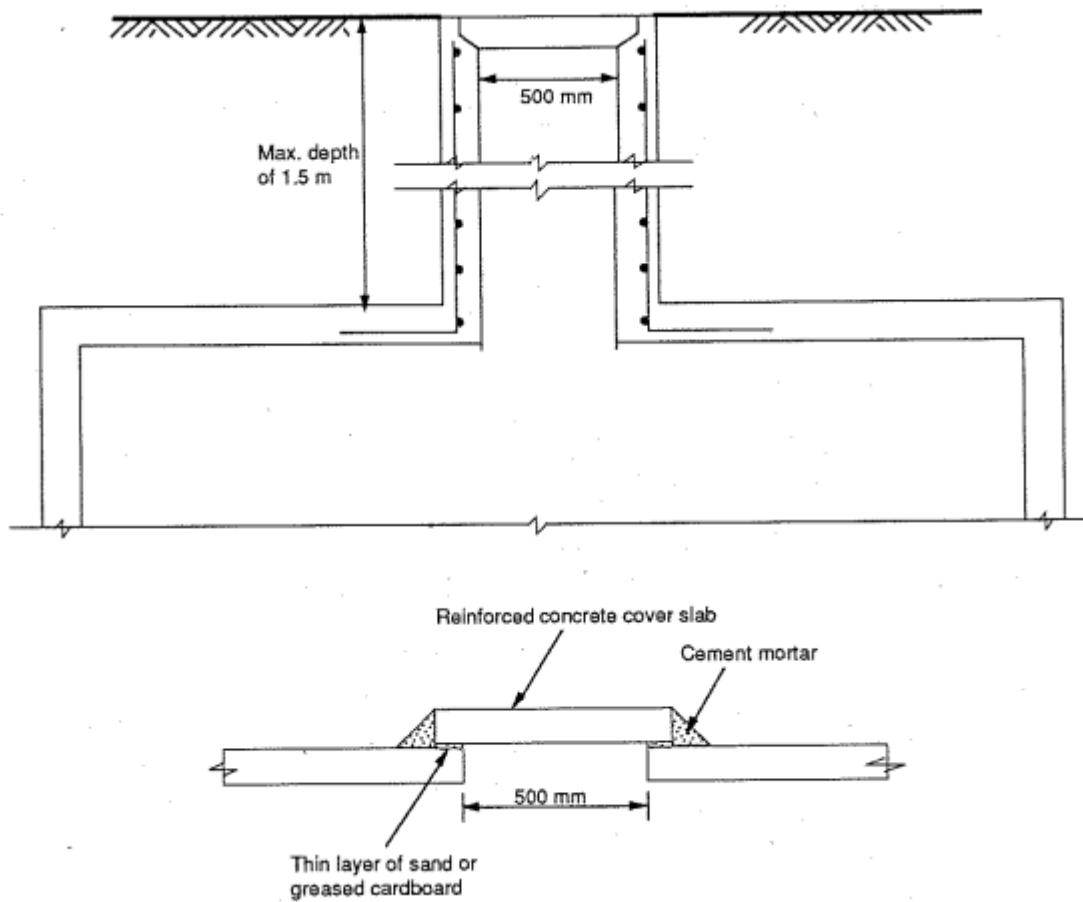

Figure 4.2.3c: Two Alternative Methods of Providing Manhole Covers

Table 4.2.3a: Reinforcement for Masonry Septic Tanks

Block wall thickness	Height of Tank (m)	Vertical bars	Horizontal bars
150	1.0	D10 @ 600	D12 @ 600
	1.2	D12 @ 600	D12 @ 600
	1.4	D12 @ 400	D12 @ 600
200	1.6	D12 @ 400	D12 @ 600
	1.8	D16 @ 600	D12 @ 600
	2.0	D12 @ 400 fill all cells	D16 @ 600

Table 4.2.3b: Septic Tank Dimensions

No. of Persons	BLACKWATER ONLY					
	A	B	C	D	W	V(m ³)
8	1,000	400	1,000	850	800	0.95
10	1,000	600	1,000	850	800	1.22
12	1,000	600	1,000	850	800	1.22
15	1,000	600	1,200	1,050	800	1.34
25	1,200	800	1,200	1,050	1,000	2.10
50	1,600	800	1,400	1,250	1,000	3.00
100	2,400	1,200	1,400	1,250	1,200	5.40
150	2,600	1,400	1,600	1,450	1,400	8.12
200	3,000	1,600	1,600	1,450	1,600	10.67
300	3,400	1,800	1,800	1,650	1,800	15.44
400	4,000	2,200	1,800	1,650	2,000	20.46
500	4,200	2,200	1,800	1,650	2,400	25.34
600	4,400	2,400	2,000	1,850	2,400	30.19

No. of Persons	ALL DOMESTIC WASTE					
	A	B	C	D	W	V(m ³)
8	1,400	800	1,000	850	1,000	1.87
10	1,400	800	1,200	1,050	1,000	2.31
12	1,800	800	1,200	1,050	1,000	2.73
15	1,800	800	1,200	1,050	1,200	3.28
25	2,000	1,200	1,400	1,250	1,400	5.60
50	3,200	1,600	1,600	1,450	1,600	11.14
100	4,000	2,000	1,800	1,650	2,200	21.78
150	5,000	2,400	2,000	1,850	2,400	32.86
200	5,600	2,400	2,000	1,850	3,000	44.40
300	6,600	3,400	2,000	1,850	3,600	66.60
400	8,000	4,000	2,000	1,850	4,000	88.80
500	8,200	4,200	2,000	1,850	4,800	110.11
600	9,000	4,800	4,000	1,850	5,200	132.76

V = Volume of Septic Tank;

For details of A, B, C, D and W see Figures 4.2.3a and 4.2.3b

Note: 'V' does not include the freeboard volume; frequency in between the desludging is about 3.5 years; assuming a 24h minimum retention time at

35 liter per capita per day (lpcd) (for wastewater) and 25 liter per capita per year (lpcy) (for sludge) at 96% moisture content.

4.2.4. Effluent absorption area

An important factor when considering the installation of a septic tank is to determine whether the soil is suitable to absorb the effluent, and whether the soil is of adequate depth and area. Generally, it can be said that the most suitable soil for an absorption area is a sandy or silty loam, and the most unsuitable soil, hard impervious clay, or rock. Where an impervious stratum such as rock or clay is present, it may not be possible to provide an absorption trench. If the slope of the ground allows the provision of imported absorbent fill of sufficient thickness, it will still be possible to have a trench or soak pit.

The absorption rate of the soil may be ascertained by carrying out the following percolation test:

At a number of representative spots within the area to be used for installation of the absorption *drains*, dig holes 300 mm square to the depth of the absorption *drain*. Pour water into the holes to a depth of 150 mm or more, and allow the water to soak away. Again, pour water into the holes to a depth of 150 mm and record the times taken for the surface of the water to fall 25 mm.

Due to its technical aspect, percolation tests are not mandatory for individual *buildings* in Section DF but is required for Institutional Buildings, Resorts and Hospitals and Industrial systems, in Section NF.

The recommended dosage of effluent in liters per metre of absorption trench per day, according to the time taken for the water surface to fall 25 mm in the test is given in Table 4.2.4, and the minimum length of the absorption trench in meters may be determined from the formula at the base of the Table.

Table 4.2.4: Length of Absorption Trench for Different Absorption Rates

Time for water level in test to fall by 25 mm (minutes)	E, Dosage of effluent (liters per meter of trench per day)
1	75
2	60
5	45
10	30
20	18
30	15
60	11

Notes:

a) Length of absorption trench in metres = 1,000 V/E, Where V is the volume given in cubic meters in Table 4.2.3b and E is the dosage of effluent in liters per area of absorption per day.

b) If the time taken for a fall in level of 25 mm is more than 60 minutes, the soil is not suited for absorption trench method of disposal.

4.2.5. Soakaway systems

Effluent from domestic household septic tanks shall be piped and discharged into a properly designed soakaway systems.

There are three types of appropriate systems:

1. Absorption trenches (recommended);
2. Separate soakaway pit; and
3. Integrated soakaway area around the septic tank.

Absorption Trenches

The soakaway may consist of an absorption trench which conforms to the following criteria:

(a) Typical dimensions

Typical dimensions for an absorption trench are approximately 450 mm in width and a minimum depth of 400 mm. The trenches are packed with 75 mm size hard stone, gravel or coral to a height of 150 mm, over which a line of perforated pipes is laid along the center of the trench, commencing about 300 mm from the beginning of the trench and thereafter running the full length of the trench. The *drain* pipe conveying the effluent to the trench extends into the trench and butts against the first perforated pipe.

(b) Joints between pipes

The joints between the pipes in the trench must not be sealed. The pipes should be surrounded and covered with 75 mm broken hard stone or hard coral to within a few millimeters from the top of the trench, over which should be placed a protective covering of old iron, bag, bark, or the like, before covering the trench with soil or turf.

(c) Absorption trench construction

The absorption trench may also be constructed of concrete slabs laid in such a manner that there are many vertical joints left open so as to allow the effluent to escape. Concrete slabs are used to cover the top of the trench, and these may themselves be covered by soil or turf.

(d) Position of absorption trench

The absorption trench should be constructed along the general contour of the ground. It must be so positioned that the prepared ground level at the trench is lower than the invert of the outlet pipe from the septic tank so as to prevent the effluent back-flooding into the septic tank. Typical absorption trenches are shown in Figure 4.2.5b and their general layout in Figure 4.2.5a.

(e) Vegetation

Moisture-seeking shrubs or other vegetation planted in the vicinity of the trench will assist in the absorption of the effluent, but care should be taken in selecting the shrubs so that their roots are not likely to interfere with the efficiency of the trench. Roof water, and as far as possible surface and ground water, must be excluded from absorption trenches, so as to maintain their efficiency

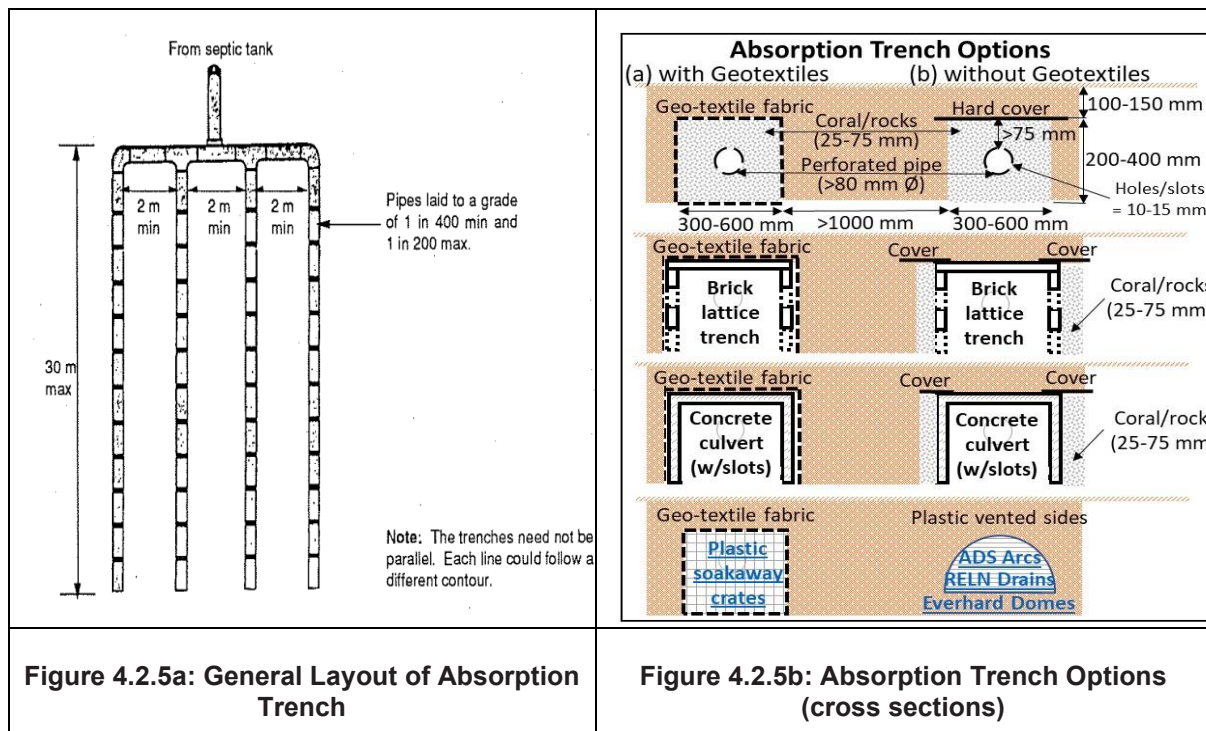

Soakaway Pits

Where sufficient area for absorption trenches is not available, but there is sufficient depth of absorbent material, soak pits may be used.

The separate soakaway pit shall conform to the following criteria:

1. Minimum surface area of soakaway pit shall be 3 m², with depth varying in function of the wastewater flow.
2. Soakaway pit shall be filled with large pieces of coral not less than 75 mm in dimension.
3. Coral fill shall be covered with rot resistant fabric, e.g., filter cloth, to stop soil washing into the soakaway.
4. Fabric shall be covered with a minimum of 300 mm of soil.

Where the soil is not stable, a typical arrangement is shown in Figure 4.2.5c. Old bitumen drums with the ends removed are shown arranged in tiers. The drums are pierced at about 200 mm centers with a pick or so. They are surrounded by 75 mm hard stone, gravel or coral. The effluent is drained into the drums. The minimum thickness of stone surrounding the drums must be 300 mm. The actual dimensions of the soak pit will depend on the nature of the soil and the volume of effluent.

In general, a soak pit is not as effective or desirable a means of disposal as absorption trenches.

Figure 4.2.5c Separate Soakaway

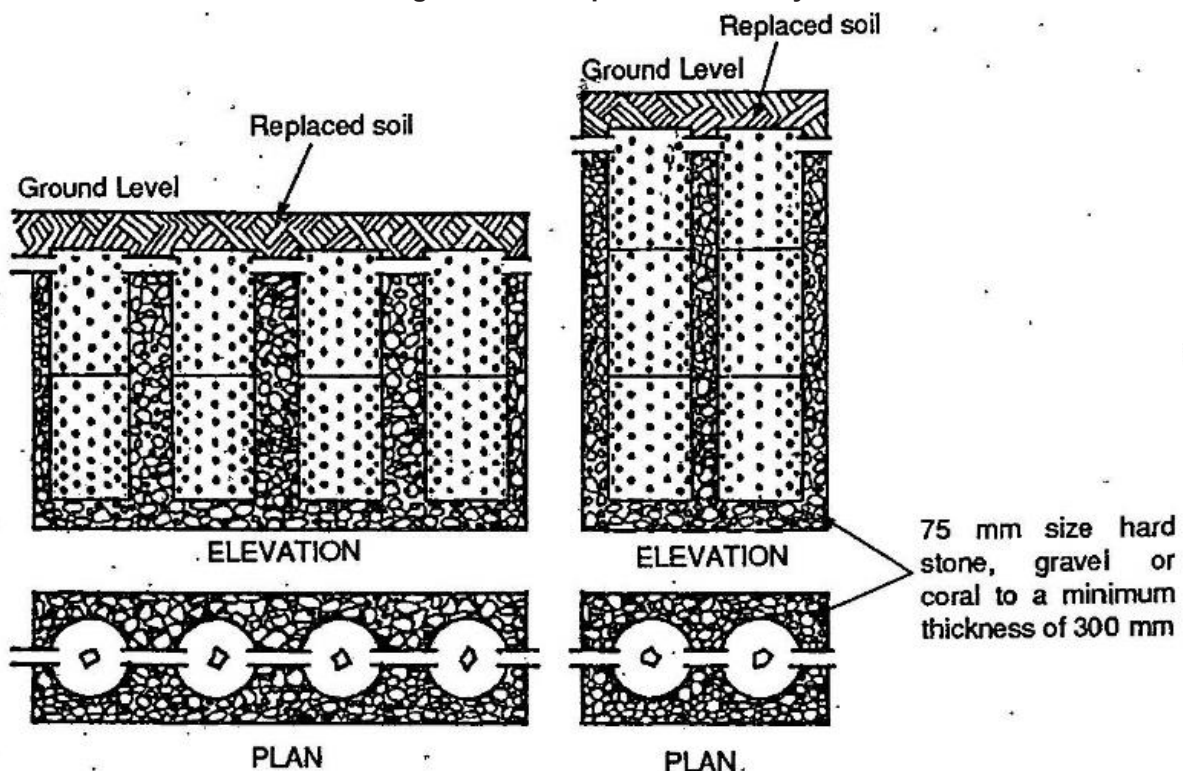

Alternative Soakaway

Alternatively, the soakaway may be integrated with the septic tank by constructing it of sufficient area, as above, under and around the base of the tank as follows:

1. Excavate the septic tank pit 500 mm deeper than usual and backfill with strong coral fill dimensions 75 mm or greater to a depth of at least 500 mm.
2. Cover the coral fill with building plastic prior to placing the concrete base slab of the septic tank.
3. Complete the septic tank construction and pipe the effluent so that is evenly dispersed through the soakaway around and underneath the tank.

Figure 4.2.5d: Integrated Soakaway

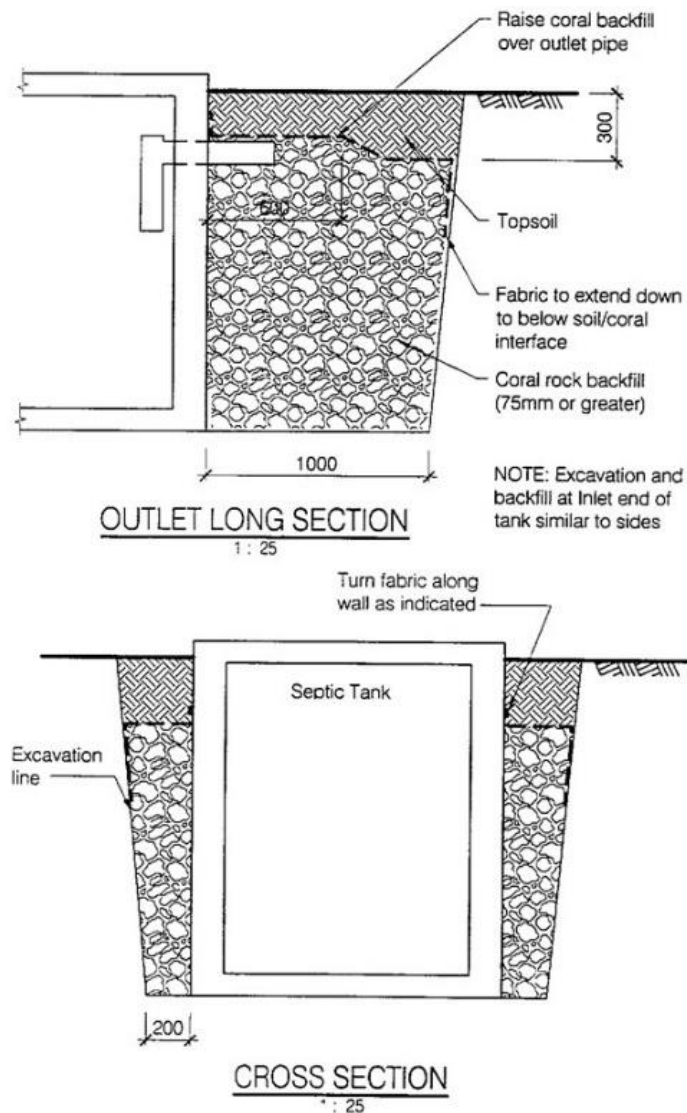

4.2.6. Desludging

Desludging shall be carried out every 5 to 8 years, or when the sludge level fills more than half of the first chamber, whichever is the earliest.

4.2.7. Grease traps

The satisfactory disposal of the discharge from kitchen *waste fixture* is frequently difficult because it is charge with grease which cannot be satisfactorily dealt with in a septic tank. This difficulty may be overcome by a grease trap located near the kitchen through which all discharge from the kitchen must pass before entering the *drain* to the septic tank. For satisfactory working of the trap, it is necessary that both laundry and roof waters, and liquid and powder detergents, be excluded from it. A grease trap constructed as shown in Figure 4.2.7 has been found effective in arresting grease.

Alternatively, a smaller precast concrete or other type of grease trap may be installed.

The capacity of the grease trap below the level of the invert of the outlet must be not less than the total capacity of the sinks and dishwashers served. The cover over the trap should be removable to facilitate the cleaning of the trap.

If grease traps are not regularly cleared of the accumulated grease it would give rise to the blocking of drains, unsightly overflow through the sides of the cover slab of the trap and unpleasant odour.

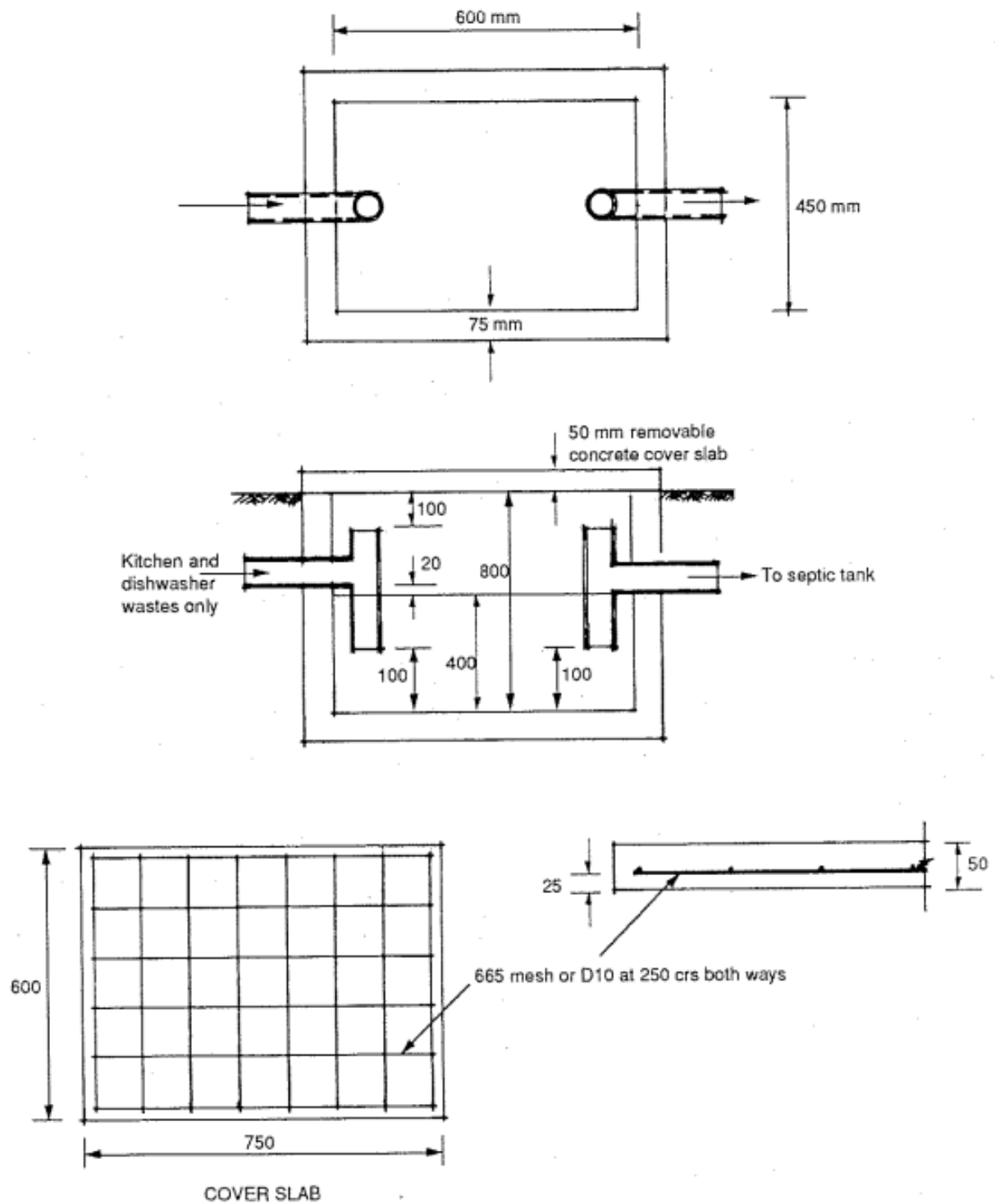

Notes:

- All dimensions in mm.
- Concrete to be 20 MPa grade
- Reinforcement – 665 mesh or D10 at 250 crs both ways all around.

Figure 4.2.7: Details of a Grease Trap

4.3. Tailored Treatment Packages

4.3.1 Application

Tailored treatment packages such as enhanced effluent soakage / sand filtering systems or Alternative Onsite Wastewater Treatment Systems shall be designed for facilities:

1. located within 15 m of drinking water source, marine or river environment and less than 1.5 m above maximum groundwater level; or
2. when more effective nutrients reduction processes are required to protect from eutrophication of water bodies and potential human health issues.

4.3.2 Design

For high groundwater environments, one of the following enhanced systems shall be used:

- Sand filters
- Mounds

A sand filter conforming with the design requirements shown in Figure 4.3.2a shall be constructed in situations where there is sufficient soil cover. In situations where there is rock or tight soil close to the surface the Mound System as shown in Figure 4.3.2b shall be utilized.

In situations where a pump station is required integral with a septic tank, a *professional consultant* shall be engaged to design the system.

Innovative / Alternative Onsite Wastewater Treatment System shall be considered to contribute to more effective nitrogen reduction processes, responsible for eutrophication of water bodies and potential human health issues.

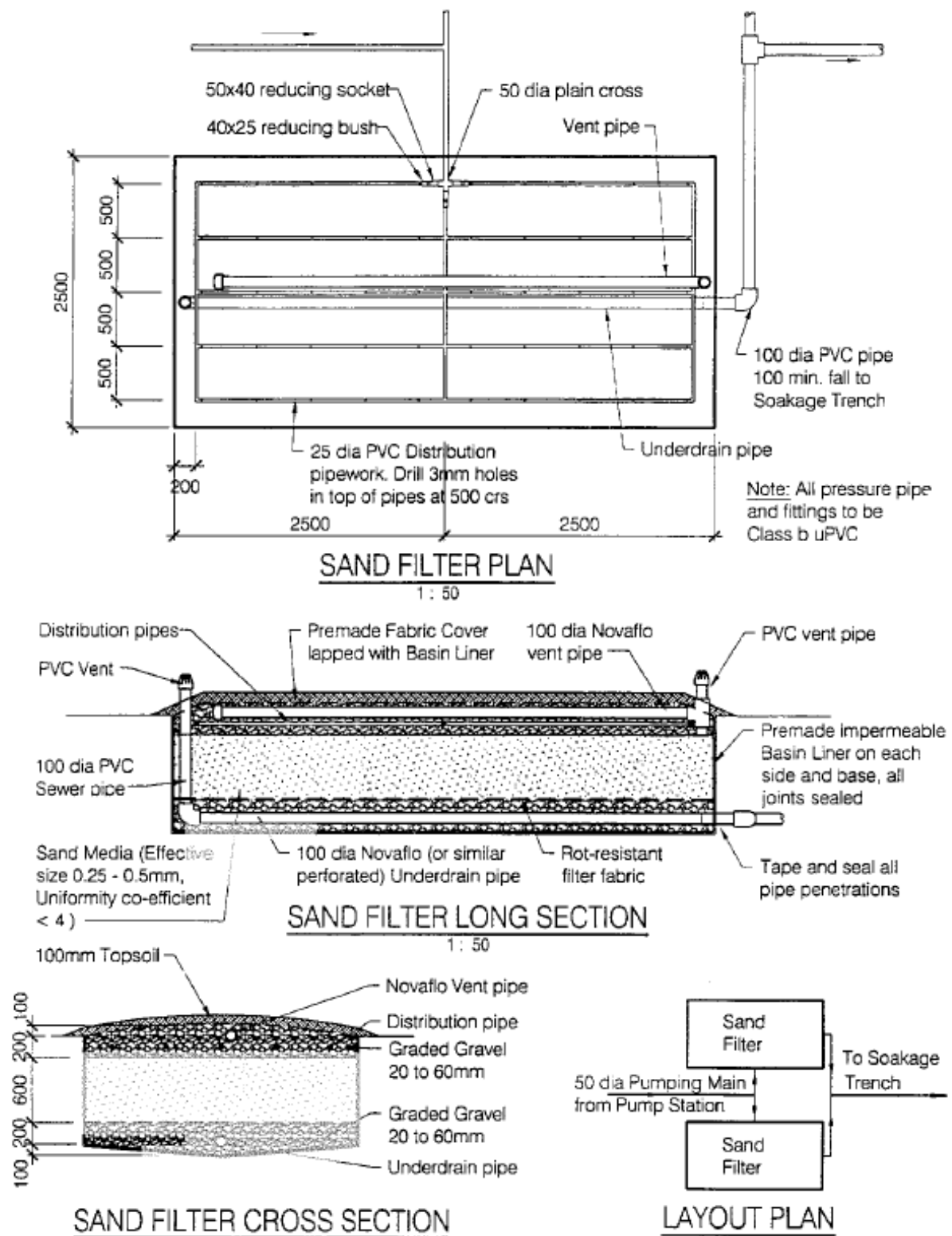
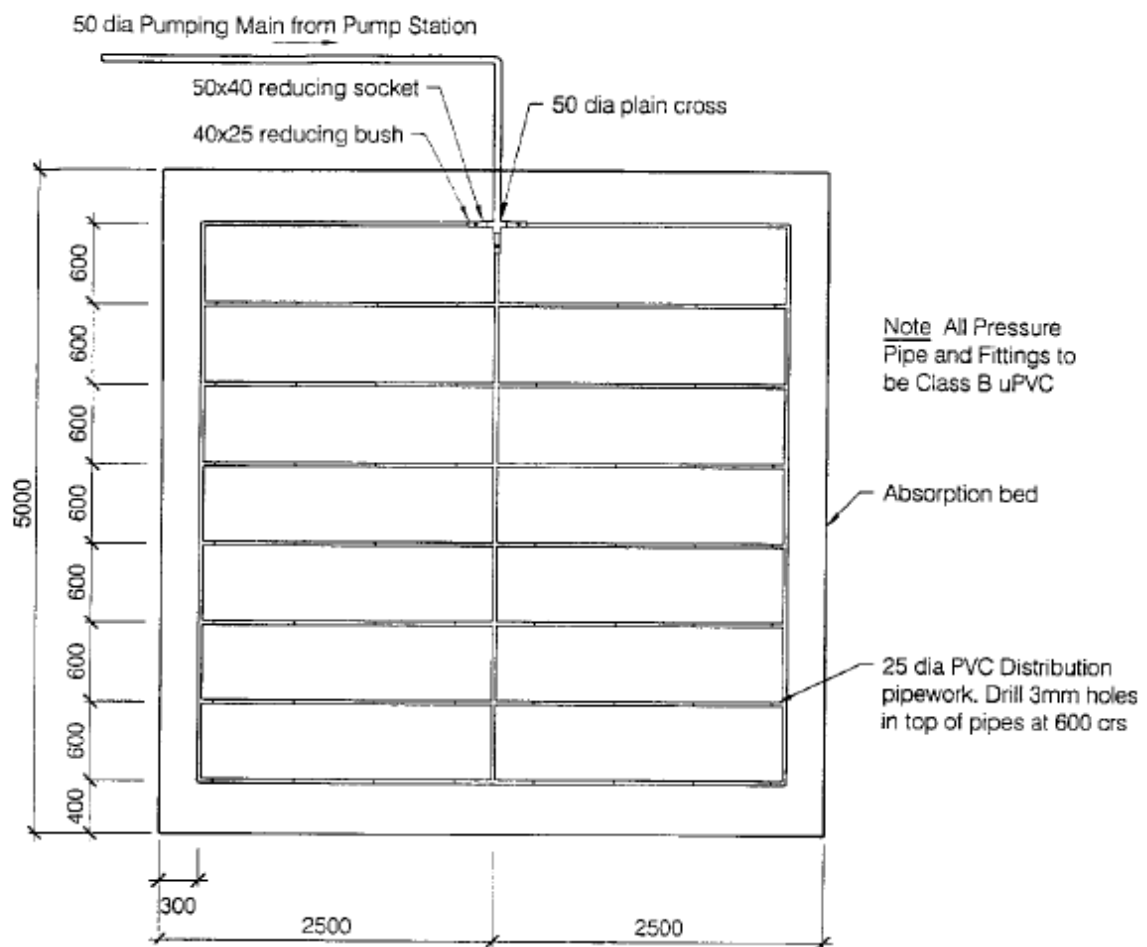
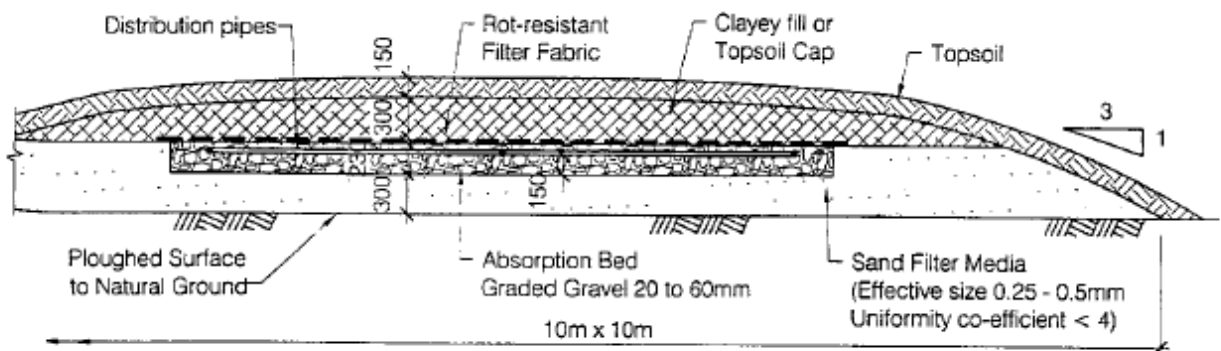

Figure 4.3.2a: Intermittent Biological Sand Filter



SAND FILTER PLAN

1: 50



TYPICAL SECTION

Figure 4.3.2b: Mound System for Domestic Use

Section

DG



ANCILLARY PROVISIONS

THIS SECTION APPLIES TO DWELLINGS AND
OUTBUILDINGS (CLASS 1 & CLASS 10)

Contents

PERFORMANCE REQUIREMENTS	1
OBJECTIVES	1
REQUIRED PERFORMANCE	1
DGP1 Minor Structures and Components	1
DGP2 Fireplaces, Chimneys and Flues	1
DEEMED-TO-SATISFY PROVISIONS	2
DG 1 Minor Structures and Components	2
DG2 Fireplaces, Chimneys and Flues	2

PERFORMANCE REQUIREMENTS

OBJECTIVES

This Section contains more specific requirements for particular parts of Class 1 and 10 *buildings*.

Parts of *buildings* and structures must be so designed and constructed that the following requirements in addition to those listed for Sections B, DC, and DF where relevant, are fulfilled.

REQUIRED PERFORMANCE

DGP1 Minor Structures and Components

DGP1.1 Swimming pools

Suitable means for the disposal of waste and drainage must be provided to a *swimming pool*.

Access by unsupervised young children to *swimming pools* must be restricted.

DGP1.2 Aesthetics

Any minor structure such as fencing awnings and the like must be suited to the general surroundings as well as the occupancy of the *building* and the neighbourhood.

DGP1.3 Animal houses

Accommodation for animals and poultry must not lead to unsanitary conditions for the occupier or neighbours and the public. The accommodation must be such that the animals or poultry are not subjected to serious discomfort or overcrowding.

DGP2 Fireplaces, Chimneys and Flues

Fireplaces, chimneys and flues must be adequately constructed or separated to prevent:

1. ignition of nearby parts of the *building*; or
2. escape or discharge of smoke to the inside of the *building* or to adjacent windows, ventilation inlets, or the like.

DEEMED-TO-SATISFY PROVISIONS

DG1 Minor Structures and Components

DG1.1 Swimming pools

Drainage: A *swimming pool* must have suitable means of drainage.

Safety fencing: A *swimming pool* with a depth of water more than 300 mm must have suitable barriers or safety fencing in accordance with AS 1926.1 and AS 1926.2 to restrict access by young children to the immediate pool surrounds if the *swimming pool* is associated with a Class 2 or 3 *building* or is a public pool.

Water recirculation systems: A *swimming pool* must have suitable means of water reticulation in accordance with AS 1926.3.

DG1.2 Poultry and other domestic animal houses

A *building* used for keeping domestic birds or animals must be not less than:

1. 12 m from any Class 1 *building*;
2. 10 m from any boundary; and
3. 20 m from the boundary adjoining an allotment containing or intended to contain any *building* other than a Class 1 *building*.

The floor of the *building* must be constructed of suitable material. Suitable arrangements must be made for the collection and disposal of animal wastes, so that they do not create a nuisance or encourage the breeding of flies and other pests. The size and general arrangements in the *building* must be conducive to the welfare of the poultry or animals.

DG1.3 Fences

Any fencing or free-standing wall must be suited to the occupancy of the *building* within. It must not detract from the general aesthetic appearance of the surroundings. If any barbed wire or other such is used it must be at a height of not less than 2 m above the finished level of any existing or intended adjacent footpath.

DG2 Fireplaces, Chimneys and Flues

NOTE: this clause does not apply to kitchens from traditional materials or “bush kitchens”.

DG2.1 General requirements

A chimney or flue must be constructed:

- (a) to withstand the temperatures likely to be generated by the appliance to which it is connected so that the temperature of the exposed faces will not exceed a level that would cause damage to nearby parts of the *building* and so that hot products of combustion will not:
 1. escape through the walls of the chimney or flue; or
 2. discharge in a position that will cause fire to spread to nearby *combustible* materials or allow smoke to penetrate through nearby *windows*, ventilation inlets, or the like;
- (b) so as to prevent rainwater penetrating to any part of the interior of the building;
- (c) such that its termination is not less than:
 1. 600 mm above any point of penetration of or contact with the roof; and
 2. 900 mm above any opening or openable part in any *building*, which is within 3 m horizontal distance of the chimney or flue; and
- (d) so that it is accessible for cleaning.

DG2.2 Open fireplaces Deemed-to-Satisfy

PART DG – ANCILLARY PROVISIONS

An open fireplace, or solid-fuel burning appliance in which the fuel-burning compartment is not enclosed, satisfies DG2.1 if it has:

- (a) a hearth constructed of stone, concrete, masonry or similar non-*combustible* material so that:
 - 1. it extends not less than 300 mm beyond the front of the fireplace opening and not less than 150 mm beyond each side of that opening;
 - 2. it extends beyond the limits of the fireplace or appliance not less than 300 mm if the fireplace or appliance is free-standing from any wall of the room;
 - 3. its upper surface does not slope away from the grate or appliance; and
 - 4. *combustible* material situated below the hearth (but not below that part *required* to extend beyond the fireplace opening or the limits of the fireplace) is not less than 155 mm from the upper surface of the hearth;
- (b) walls forming the sides and back of the fireplace up to not less than 300 mm above the underside of the arch or lintel which:
 - 1. are constructed in 2 separate leaves of solid masonry not less than 180 mm thick, excluding any cavity; and
 - 2. do not consist of concrete block masonry in the construction of the inner leaf;
- (c) walls of the chimney above the level referred to in (b) that are:
 - 1. constructed of masonry units with a net volume, excluding cored and similar holes, not less than 75% of their gross volume, measured on the overall rectangular shape of the units, and with an actual thickness of not less than 90 mm; and
 - 2. lined internally to a thickness of not less than 12 mm with rendering consisting of 1 part cement, 3 parts lime, and 10 parts sand by volume, or other suitable material; and
- (d) suitable damp-proof courses or flashing to maintain weatherproofing.

PART

3



PUBLIC BUILDINGS AND GROUP DWELLINGS (CLASS 2 TO CLASS 9)

Section



FIRE RESISTANCE

**THIS SECTION APPLIES TO PUBLIC
BUILDINGS AND GROUP DWELLINGS
(CLASS 2 to CLASS 9)**

SECTION NC – FIRE RESISTANCE

Contents

PERFORMANCE REQUIREMENTS	1
OBJECTIVES 1	
NCP1 Fire Resistance and Stability	1
NCP2 Compartmentation and Separation	1
NCP3 Protection of Openings	1
REQUIRED PERFORMANCE	1
DEEMED-TO-SATISFY PROVISIONS	3
NC1 FIRE RESISTANCE AND STABILITY	3
NC1.1 Type of construction required	3
NC1.2 Calculation of rise in storeys	3
NC1.3 Mixed types of construction.....	3
NC1.4 Open spectator stands and indoor sports stadiums	3
NC1.5 Lightweight construction	4
NC1.6 Early fire hazard Indices	4
NC1.7 Non-combustible building elements.....	4
NC 2 Compartmentation and Separation	5
NC2.1 Application	5
NC2.2 General floor area limitations	5
NC2.3 Large Isolated Buildings of Class 5,6,7,8 or 9b.....	5
NC2.4 Requirements for open spaces and vehicular access	5
NC2.5 Class 9a buildings.....	6
NC2.6 Separation of openings in external walls	6
NC2.7 Separation by fire walls	6
NC2.8 Separation of classifications in the same storey	7
NC2.9 Separation of classifications in different storeys	7
NC2.10 Separation of lift shafts	7
NC2.11 Stairways and lifts in one shaft.....	7
NC2.12 Separation of equipment.....	7
NC2.13 Electricity Substations	7
NC3 PROTECTION OF OPENINGS	8

SECTION NC – FIRE RESISTANCE

NC3.1 Application of part	8
NC3.2 Protection of openings in external walls	8
NC3.3 Separation of openings in different fire compartments	8
NC3.4 Acceptable Methods of Protection.....	9
NC3.5 Doorways in fire walls	9
NC3.6 Sliding fire doors	9
NC3.7 Protection of doorways in horizontal exits	9
NC3.8 Openings in fire-isolated exits	10
NC3.9 Service penetrations in fire-isolated exits.....	10
NC3.10 Openings in fire-isolated lift shafts.....	10
NC3.11 Bounding construction: Class 2,3 and 4 buildings	10
NC3.12 Openings in floors for services.....	11
NC3.13 Openings in shafts	11
NC3.14 Openings for service installations	11
NC3.15 Installation deemed-to-satisfy.....	11

SPECIFICATIONS

SPECIFICATION NC1.1: Fire-Resisting Construction

SPECIFICATION NC1.5: Structural Test for Lightweight Construction

SPECIFICATION NC1.6: Early Fire Hazard Indices

SPECIFICATION NC3.4: Fire Doors, Smoke Doors, Fire Windows & Shutters

SPECIFICATION NC3.15: Penetration of Walls, Floors & Ceilings by Services

PERFORMANCE REQUIREMENTS

OBJECTIVES

The design and construction of *buildings* must fulfill the following objectives:

NCP1 Fire Resistance and Stability

A *building* must be constructed so that it is protected from fire in any other *building*. Materials used in the construction must be such that if there is a fire in the *building*:

1. the spread of fire and the generation of smoke and toxic gases will be minimized;
2. stability will be maintained for a period at least sufficient for the occupants to escape and to ensure the safety of fire- fighters; and
3. there will be little risk of collapse onto adjoining property.

NCP2 Compartmentation and Separation

Buildings must be constructed to localize the effects of fire to the areas of origin. Adequate levels of passive fire protection must be provided so that sufficient time is available for the users and others to escape from the effects of fire and as an alternative, to allow the users to stay safely within unaffected compartments for the duration reasonably required to put out the fire by active means.

NCP3 Protection of Openings

Openings must be protected and service penetrations must be fire-stopped to maintain separation and compartmentation.

REQUIRED PERFORMANCE

NCP1.1 In order to maintain the *structural adequacy* and stability of any *building* for a sufficient time for the safety of the users, firefighters, and others, the following must be ensured:

1. the *loadbearing* elements must have the FRL appropriate to their function in the *building*;
2. the expected fire load density, the fire risk, the height of the *building*, its location with reference to the availability of external firefighting resources, and the fire control measures available within the *building* must be appropriate;
3. the FRL of structural elements must be at least equal to that of other elements to which they provide support; and
4. the collapse of elements with a lower FRL must not result in the collapse of elements with a higher FRL.

NCP2.1 The size of a *fire compartment* must also be consistent with the fire severity of the fire load density it contains and the likely spread of fire between it and any other compartment, *storey* or *building*.

Building compartment size and separating construction must be such that the potential size of a fire and the spread of fire and smoke are limited in order to:

1. protect the occupants of one part of a *building* from the effects of fire elsewhere in the *building*;
2. control the spread of fire or smoke to adjoining *buildings*; and
3. facilitate access to the *building* by firefighters.

NCP 3.1 Openings of any nature in the envelope surrounding *fire compartments* must be so protected that they do not allow the passage of dangerous amounts of heat, flames, smoke and gases in the event of a fire within or outside the compartment and for a period sufficient to:

1. allow the safe evacuation of all affected people; and
2. allow firefighters to fight the fire.

SECTION NC – FIRE RESISTANCE

The sufficiency of the duration allowed must take into account the nature of occupancy of the *building* as well as the proximity of other *buildings* and their occupancy

DEEMED-TO-SATISFY PROVISIONS

NC1 FIRE RESISTANCE AND STABILITY

NC1.1 Type of Construction Required

The minimum Type of *fire-resisting construction* of a *building* must be that give in Table NC1.1, except as allowed for:

1. *open spectator* stands and indoor sports stadiums in NC1.4; and
2. *lightweight* construction in NC1.5.

Type A construction is the most fire-resistant and Type C the least fire-resistant of the Types of construction.

Table NC1.1: Type of Construction Required

Rise in storeys	Class of building: 2, 3, 9	Class of building: 5, 6, 7, 8
4 or more	Requires specific design	Requires specific design
3	Type A	Type B
2	Type B	Type C
1	Type C	Type C
Note: See Specification NC1.1 for details of Type A, B and C construction.		

NC1.2 Calculation of Rise in Storeys

In calculating the *rise* in *storeys*:

(a) a *storey* that has an average internal height of more than 6 m is counted as:

1. 1 *storey* if it is the only *storey* above the ground; or
2. 2 *storeys* in any other case; and

(b) a *storey* is not counted if:

1. it is situated at the top of the *building* and contains only service units or equipment; or
2. it is situated partly below the finished ground and the underside of the ceilings is not more than 1 m above the average finished level of the ground at the *external wall*, or if the *external wall* is more than 12 m long, the average for the 12 m part where the ground is lowest.

NC1.3 Mixed Types of Construction

A *building* may be of mixed Types of construction if no part of the *building* is supported by, or vertically over, a part of a less *fire-resistant* Type.

NC1.4 Open Spectator Stands and Indoor Sports Stadiums

An *open spectator stand* or indoor sports stadium that has only changing rooms, sanitary facilities, or the like below the tiered seating, need not comply with the other provision of this Part if it contains not more than 1 tier of seating and is of Type C and *non-combustible* construction.

NC1.5 Lightweight Construction

Lightweight construction must comply with Specification NC1.5 if it is used in construction which is required to be *fire-resisting*.

NC1.6 Early Fire Hazard Indices

The Early Fire Hazard Indices of materials and assemblies inside Class 2 to 9 *buildings* must comply with Specification NC1.6.

NC1.7 Non-combustible Building Elements

- (a) In a *building* required to be of Type A or B construction, the following *building elements* and their components must be non-combustible:
1. external walls and *common walls*, including all components incorporated in them including the facade covering, framing, and insulation;
 2. the flooring and floor framing of lift pits; and
 3. non-loadbearing internal walls where they are required to be *fire-resisting*.
- (b) A shaft, being a lift, ventilating, pipe, garbage, or similar shaft that is not for the discharge of hot products of combustion, that is non-loadbearing, must be of non-combustible construction in:
1. a *building* required to be of Type A construction; and
 2. a *building* is to be of Type B construction, subject to C2.10, in:
 - a. a Class 2, 3 or 9 *building*; and
 - b. a Class 5, 6, 7 or 8 *building* if the shaft connects more than 2 *storeys*.
- (c) A loadbearing internal wall and a loadbearing fire wall, including those that are part of a loadbearing shaft, must comply with Specification NC4.1.
- (d) The requirements of (a) and (b) do not apply to the following:
1. gaskets;
 2. caulking;
 3. sealants;
 4. termite management systems;
 5. glass, including laminated glass;
 6. thermal breaks associated with glazing systems; and
 7. damp-proof courses.
- (e) The following materials may be used wherever a non-combustible material is required:
1. plasterboard;
 2. perforated gypsum lath with a normal paper finish;
 3. fibrous-plaster sheet;
 4. fibre-reinforced cement sheeting;
 5. pre-finished metal sheeting having a combustible surface finish not exceeding 1 mm thickness and where the Spread-of-Flame Index of the product is not greater than 0;
 6. sarking-type materials that do not exceed 1 mm in thickness and have a Flammability Index not greater than 5;
 7. bonded laminated materials where:
 - a. each lamina, including any core, is non-combustible;
 - b. each adhesive layer does not exceed 1 mm in thickness and the total thickness of the adhesive layers does not exceed 2 mm; and
 - c. the Spread-of-Flame Index and the Smoke-Developed Index of the bonded laminated material do not exceed 0 and 3 respectively.

NC 2 COMPARTMENTATION AND SEPARATION

NC2.1 Application

This Part does not apply to an *open-deck carpark* or *open spectator stand*.

NC2.2 General Floor Area Limitations

The size of any *fire compartment* in a Class 5, 6, 7, 8, or 9b *building* must not exceed the relevant maximum *floor area* and volume set out in Table NC2.2, except as permitted in NC2.3.

A part of a *building* which contains only heating, ventilating, or lift equipment, water tanks, or similar service units is not counted in the *floor area* or volume of a *fire compartment* if it is situated at the top of the *building*.

Table NC2.2: Maximum Size of Fire Compartments

	TYPE OF CONSTRUCTION OF BUILDING			
		Type A	Type B	Type C
CLASS 5, 6, 7, 8, or 9b	Max floor area	2,000 m ²	1,500 m ²	1,000 m ²
	Max volume	12,000 m ³	9,000 m ³	6,000 m ³

NC2.3 Large Isolated Buildings of Class 5, 6, 7, 8, or 9b

The *floor area* of a *fire compartment* in a large, isolated *building* may exceed that specified in Table NC2.2 to the following limits and conditions:

- (a) Up to 1,800 m² if the *building* is Class 7 or 8, it contains not more than 2 *storeys*, and an *open space* complying with NC2.4a not less than 18 m wide is provided around the *building*.
- (b) More than 1,800 m² if:
 1. the ceiling height of the *fire compartment* is not more than 12 m, it has a smoke exhaust system in accordance with specification NE2.6 or smoke-and-heat vents, and the space below the roof is divided into compartments in accordance with AS 2665; and
 2. the ceiling height is more than 12 m and it has a smoke exhaust system in accordance with Specification NE2.6.
- (c) If more than one *building* is on the allotment:
 1. each *building* complies with (a) or (b); or
 2. if the *buildings* are closer than 6 m to each other and no *building* is more than 45 m from the required vehicular access, they are regarded as one *building*, and collectively comply with (a) or (b).

NC2.4 Requirements for Open Spaces and Vehicular Access

- (a) An *open space* required by NC2.3 must:
 1. be wholly within the allotment except as in point 3 below;
 2. include vehicular access in accordance with (b);
 3. be next to the boundaries of the allotment, and may include any road, river, or public place adjoining the allotment;
 4. not be used for the storage or processing of materials; and
 5. not be built upon, except for guard houses and services structures (such as substations and pump houses) which may encroach upon the width of the space if they do not unduly impede firefighting at any part of the perimeter of the allotment or unduly add to the risk of spread of fire to any *building* on an adjoining allotment.
- (b) The vehicular access *required* by this Part:
 1. must be capable of providing emergency vehicle access and passage from the public road;
 2. must have a minimum unobstructed width of 6 m and in no part be built upon or used for

- any purpose other than vehicular or pedestrian movement;
3. may be substituted by a public road if the *building* faces and is accessible from the road, and is no further than 45 m from it;
 4. must be such that reasonable pedestrian access from the vehicular access to the *building* is available; and
 5. must be of adequate load bearing capacity and unobstructed height to permit the operation and passage of Fire Brigade vehicles.

NC2.5 Class 9a Buildings

The *building* must be divided into *fire compartments* with a maximum *floor area* of 1,700m² and further:

- (a) *Ward areas* must be subdivided with walls of minimum FRL of 60/60/60 into *floor areas* of not more than 850 m² and again subdivided into parts of 425 m² maximum *floor area* with smoke-proof walls complying with (c);
- (b) other than *ward areas* must be subdivided into parts with a maximum *floor area* of 425 m² with smoke proof walls complying with (c);
- (c) a wall *required* to be smoke-proof must:
 1. be *non-combustible* and extend to the underside of the floor above or of the roof covering;
 2. only have doorways which are fitted with smoke doors complying with Specification NC3.4 and which do not extend higher than 800 mm from the underside of an imperforate roof covering, floor or ceiling above it; and
 3. not incorporate any other opening which is not smoke-proof; and
- (d) *Fire compartments* must be separated from the remainder of the *building* by *fire walls* and:
 1. in Type A construction – floors and roof or ceiling as *required* in Specification NC1.1;
 2. in Type B construction – floors with an FRL of not less than 90/90/90; and
 3. in Type C construction – floors with an FRL of not less than 60/60/60.

NC2.6 Separation of openings in external walls

In any *building* that is other than:

1. an open deck car park; or
2. of one or two *storeys* rise;

if any part of a *window* or other opening in an *external wall* (except openings in the same stairway) is situated above another opening in the *storey* next below, the opening must be protected by:

- (a) a slab or other horizontal construction that:
 1. projects outwards from the external face of the wall not less than 1,100 mm;
 2. extends not less than 450 mm beyond the openings concerned; and
 3. is of non-combustible material having an FRL not less than 60/60/60; or
- (b) a spandrel that:
 1. is not less than 1,100 mm in height;
 2. extends not less than 600mm above the upper surface of the intervening floor; and
 3. is of *non-combustible* material having an FRL not less than 60/60/60; or
- (c) providing the *window* or opening in the upper *storey* with a glazing system with an FRL of not less than –/60/30. Any gap in the construction which separates the two *storeys* must be packed with a *non-combustible* material that will withstand the relative thermal or structural movements of the walling and glazing without loss of seal.

Note: These requirements are separate from the structural requirements for glazing at B1.4.

NC2.7 Separation by fire walls

A part of a *building* separated from the remainder of the *building* by a *fire wall* is treated as a separate *building* if:

- (a) the fire wall:
 1. extends through all *storeys* and spaces in the nature of *storeys* that are common to that part and any adjoining part of the *building*;
 2. is carried through to the underside of the roof covering; and

3. has the relevant FRL prescribed by Specification NC1.1 for each of the adjoining parts, and if these are different, the greater FRL;
- (b) any openings in a *fire wall* comply with Part NC3;
- (c) timber purlins or other *combustible* material do not pass through or cross the *fire wall*; and
- (d) where the roof of one of the adjoining parts is lower than the roof of the other part, the fire wall extends to the underside of:
1. the covering of the higher roof, or not less than 6 m above the covering of the lower roof;
 2. the lower roof if it has an FRL not less than that of the *fire wall* and no openings closer than 3 m to any wall above the lower roof, or
 3. the design of the *building* must otherwise restrict the spread of fire from the lower part to the higher part.

NC2.8 Separation of Classifications in the Same Storey

If a *building* has parts of different classifications located alongside one another in the same *storey*:

1. each *building element* in that *storey* must have the higher FRL prescribed in Specification NC1.1 for that element for the classifications concerned; or
2. the parts must be separated in that *storey* by a *fire wall* with whichever is the greater of the higher FRL prescribed in Specification NC1.1 for the classifications concerned.

NC2.9 Separation of Classifications in Different Storeys

If parts of different classification are situated one above the other in adjoining *storeys* they must be separated as follows:

1. Type A or B construction – The floor between the adjoining parts must have an FRL not less than that prescribed in Specification NC1.1 for the classification of the lower *storey*.
2. Type C construction – The underside of the floor (including the sides and underside of any floor beams) must have a *fire-protective covering*.

NC2.10 Separation of lift shafts

Any lift (other than if wholly in an *atrium*) must be separated from the remainder of the *building* by enclosure in a *shaft* with its FRL as prescribed by specification NC1.1. If it connects more than two *storeys* then the openings for the lift landing doors and services must be protected in accordance with Part NC3.

NC2.11 Stairways and lifts in one shaft

A stairway and lift must not be in the same *shaft* if either the stairway or the lift is *required* to be in a *fire-resisting shaft*.

NC2.12 Separation of equipment

A wall having an FRL of not less than 60/60/60 must bound a room housing equipment comprising:

- (a) lift motors and lift control panels;
- (b) the main electrical switchboard in a building with an effective height of more than 25 m;
- (c) required stair pressurizing equipment; or
- (d) boilers, emergency batteries, emergency generators or central smoke control plant, except:
 1. equipment located in a separate *storey* (or in the topmost *storey*) and separated from the remainder of the *building* by floor construction having an FRL of 60/60/60;
 2. smoke control exhaust fans located in the air stream if they are constructed for high temperature operation in accordance with Specification NE2.6; or
 3. equipment that is otherwise adequately separated from the remainder of the *building*.

NC2.13 Electricity Substations

If an electricity substation is situated within a *building*:

1. it must be separated from any other part of the *building* by construction having an FRL of not less than 120/120/120;

2. doors, windows and any other openings on an *external wall* need not have an FRL if such openings are no closer to a *fire source feature* or *exit* than 3 m. Any other doorways including those opening to any other part of the *building* must be protected with *self-closing* -/120/60 fire doors;
3. electricity supply cables between a main and the substation, and between the substation and the main switchboard, must be enclosed or otherwise protected by construction having an FRL of not less than 120/120/120; and
4. any openings, fans or grilles for natural or mechanical ventilation must be located only on an *external wall* unless protected with an *automatic* -/120/60 fire shutter.

NC3 PROTECTION OF OPENINGS

NC3.1 Application of Part

- (a) This Part does not apply to:
 1. control joints, weep holes, and the like, in masonry construction, and joints between pre-cast concrete panels, if they are not larger than necessary for the purpose; or
 2. *non-combustible* ventilators for sub-floor or cavity ventilation, if each does not exceed 45,000 mm² in face area and is spaced not less than 2 m from any other ventilator in the same wall.
- (b) This Part applies to openings in *building elements required* to be *fire-resisting*, including doorways, windows (including any associated fanlight or infill panel) and other fixed or openable glazed areas that do not have the *required* FRL.

NC3.2 Protection of Openings in External Walls

Openings in an *external wall* that is *required* to have an FRL must:

- (a) be not less distance from a *fire-source feature* to which it is exposed than:
 1. 1 m in a *building* not more than 1 *storey* in *rise*; or
 2. 1.5 m in a *building* more than 1 *storey* in *rise*;
- (b) be protected in accordance with NC3.4 if it is situated closer from a *fire-source feature* to which it is exposed than:
 1. 3 m from a side or rear boundary of the allotment;
 2. 6 m from the far boundary of a road adjoining the allotment; or
 3. 6 m from another *building* on the allotment that is not Class 10; and
- (c) if *required* to be protected under (b), not occupy more than 1/3 of the area of the *external wall* of the *storey* in which it is located unless:
 1. they are in Class 9b *building* used as an *open spectator stand*; or
 2. they face a public road and are located in a *storey* at ground level.

NC3.3 Separation of Openings in Different Fire Compartments

Unless they are protected in accordance with NC3.4, the distance between openings in *external walls* in compartments separated by a *fire wall* must not be less than that set out in Table NC3.3.

Table NC3.3: Distance Between Openings in Different Compartments

Angle between walls	Minimum distance between openings
0° (walls opposite)	6 m
more than 0° to 45°	5 m

more than 45° to 90°	4 m
more than 90° to 135°	3 m
more than 135° to 160°	2 m

NC3.4 Acceptable Methods of Protection

- (a) Where protection is *required*, doorways, windows, and other openings must be fitted with suitable:
1. **Doorways:** -/60/30 *self-closing* or *automatic* fire doors and fire shutters;
 2. **Windows:** -/60/30 *fire windows* (*automatic* or permanently fixed in the closed position) or -/60/30 *automatic* fire shutters;
 3. **Other openings:** construction having an FRL not less than -/60/30;
- (b) Fire doors, smoke doors, fire windows and fire shutters satisfy (a) if they comply with Specification NC3.4.

NC3.5 Doorways in fire walls

The aggregate width of openings for doorways in a *fire wall* which are not part of a *horizontal exit* must not exceed $\frac{1}{2}$ of the length of the *fire wall*, and each doorway must be protected by:

- (a) Two fire doors or fire shutters, one on each side of the doorway, each of which:
1. has an FRL of not less than $\frac{1}{2}$ that *required* by Specification NC1.1 for the *fire wall*; and
 2. is *self-closing* unless provided with an *automatic* release mechanism for any hold-open device which will close the door upon actuation of any of the fire/smoke detection systems installed on both sides of the *fire wall*;
- (b) a fire door on one side and a fire shutter on the other side of the doorway, each of which complies with (a); or
- (c) a single fire door or a non-metallic fire shutter, which:
1. has an FRL of not less than that *required* by Specification NC1.1 for the *fire wall*; and
 2. is *self-closing* unless provided with an *automatic* release mechanism for any hold open device which will close the door upon actuation of any of the fire-smoke detection systems installed on both sides of the *fire wall* (based on the reliability of the fire alarm, inspection, testing, and assurance of maintenance servicing capability).

NC3.6 Sliding Fire Doors

If a doorway in a *fire wall* is fitted with a sliding fire door, which is open when the *building* is in use:

1. it must be held open with a fusible link, or an electromagnetic device, which, when de-activated, allows the door to be fully closed not less than 20 seconds, and not more than 30 seconds, after release; and
2. thermal or smoke detectors as appropriate must be installed on each side of the doorway, in accordance with NZS 4232; and
3. an audible warning device located near the doorway and red flashing warning light of a suitable intensity on each side of the doorway must be activated when a required detector in the part of the building served by the door is activated; and
4. signs must be installed on each side of the doorway located directly over the opening stating:

WARNING: SLIDING FIRE DOOR

in capital letters not less than 50 mm high in a colour contrasting with the background.

NC3.7 Protection of Doorways in Horizontal Exits

A doorway that is part of a *horizontal exit* must be protected:

1. in a Class 7 or 8 *building*: by 2 fire doors, one on each side of the doorway, each with an FRL of not less than $\frac{1}{2}$ that *required* by Specification NC1.1 for the *fire wall*; or
2. in all classes of *buildings*, by a single fire door which has an FRL of not less than that

required by Specification NC1.1 for the *fire wall*;

and each door must be *self-closing* or provided with *automatic* release of any hold-open device upon detection of smoke of fire.

NC3.8 Openings in Fire-Isolated Exits

- (a) A doorway that does not open to a road or *open space* must be protected by a *self-closing* or *automatic* -/60/30 fire door if it opens to a *fire-isolated stairway*, *fire-isolated passageway* or *fire-isolated ramp*.
- (b) A *window* in an *external wall* of a *fire-isolated stairway*, *fire-isolated passageway*, or *fire-isolated ramp* must be protected in accordance with NC3.4 if it is within 6 m of, and exposed to:
 - 1. a fire-source feature; or
 - 2. another window or other opening in a wall of the same *building*, unless they both serve the same fire-isolated enclosure.

NC3.9 Service penetrations in fire-isolated exits

Fire-isolated *exits* must not be penetrated by any service other than:

- (a) electrical wiring associated with a lighting or pressurizing system servicing the *exit*;
- (b) ducting associated with the pressurizing system if it:
 - 1. is constructed of material having an FRL of not less than 60/60/60 where it passes through any other part of the *building*; and
 - 2. does not open into any other part of the *building*; or
- (c) water supply pipes for the services or domestic use.

NC3.10 Openings in Fire-Isolated Lift Shafts

- (a) **Doorways:** If a lift *shaft* is *required* to be fire-isolated under Part NC2, an entrance doorway to that *shaft* must be protected by:
 - 1. -/60/30 fire doors that:
 - 2. comply with AS 1735.11; and are set to remain closed except when discharging or receiving passengers, goods or vehicles.
- (b) **Lift Indicator panel:** A lift call panel, indicator panel or other panel in the wall of a fire-isolated lift *shaft* must be backed by construction having an FRL of not less than 60/60/60 if it exceeds 35 x 103 mm² in area.

NC3.11 Bounding Construction: Class 2, 3, and 4 Buildings

- (a) A doorway in a Class 2 or 3 building must be protected if it provides access from a *sole-occupancy unit* to:
 - 1. a *public corridor*, public hallway, or the like;
 - 2. a room not within a *sole-occupancy unit*;
 - 3. the landing of an internal non-*fire-isolated stairway* that serves as a *required exit*; or
 - 4. another sole-occupancy unit.
- (b) A doorway in a Class 4 part must be protected if it provides access to any other internal part of the *building*.
- (c) Protection for a doorway must be at least:
 - 1. in a *building* of Type A or B construction: a *self-closing* -/30/30 fire door; and
 - 2. in a *building* to Type C construction: a *self-closing* tight fitting solid core door not less than 35mm thick in a rebated frame.

Other openings in *internal walls* which are *required* to have an FRL to inhibit the lateral spread of fire must not reduce the *fire-resisting* performance of the wall.

NC3.12 Openings in Floors for Services

In a *building* of Type A and B construction, services associated with the functioning of the *building* and passing through a floor must either be installed in *shafts* complying with Specification NC1.1 or protected in accordance with NC3.14.

NC3.13 Openings in Shafts

In a *building* of Type A or B construction, an opening in a wall providing access to a ventilating, pipe, garbage or other service *shaft* must be protected by:

1. if it is in a *sanitary compartment*: a door or panel which, together with its frame, has an FRL of not less than -/30/-; or
2. a *self-closing* -/30/- fire door or hopper; or
3. an access panel having an FRL or not less than -/30/-.

NC3.14 Openings for Service Installations

An electrical, electronic, plumbing, mechanical ventilation or air-conditioning, or other service that penetrates a *building element* (other than an *external wall* or roof) that is *required* to have an FRL or a *resistance to the incipient spread of fire*, must be installed so that the *fire-resisting* performance of the *building element* is not impaired.

NC3.15 Installation Deemed-To-Satisfy

Installation satisfies NC3.14 if:

- (a) the method and materials used are identical with a prototype assembly of the service and *building element* which has achieved the *required* FRL or *resistance to the incipient spread of fire*;
- (b) it complies with (a) except for the *insulation* criterion relating to the service when:
 1. the service is farther than 100 mm from any *combustible* material; and
 2. it is not located in a *required exit*;
- (c) in the case of ventilating or air-conditioning ducts or equipment the installation is in accordance with AS/NZS 1668.1;
- (d) the service is a metal pipe installed in accordance with Specification NC3.15 and it penetrates a wall, floor or ceiling, but not a ceiling *required* to have a *resistance to the incipient spread of fire*;
- (e) the service is sanitary plumbing installed in accordance with Specification NC3.15 and it:
 1. is of metal or UPVC pipe;
 2. penetrates the floors of a Class 5, 6, 7, 8, or 9b *building*; and
 3. is in *sanitary compartments* which are separated from other parts of the *building* by walls with the FRL *required* by Specification NC1.1 for a stair *shaft* in the *building* and a *self-closing* -/60/30 fire door;
- (f) the service is a wire or cable, or a cluster of wires or cables installed in accordance with Specification NC3.15 and it penetrates a wall, floor or ceiling, but not a ceiling *required* to have a *resistance to the incipient spread of fire*; or
- (g) the service is an electrical switch, outlet, or the like, and it is installed in accordance with Specification NC3.15.

SPECIFICATION NC1.1

Fire-Resisting Construction

Contents

1. Scope	13
2. General requirements	13
2.1 Exposure to Fire-source Features.....	13
2.2 Fire Protection for a Support of Another Part.....	13
2.3 Lintels.....	13
2.4 Attachments not to Impair Fire-resistance.....	13
2.5 General Concessions	14
3. Type A Fire-resisting construction.....	14
3.1 Fire-resistance of building elements	14
3.2 Concessions for Floors.....	14
3.3 Floor Loading of Class 5 and 9b Buildings: Concession	16
3.4 Roof Superimposed on Concrete Slab: Concession.....	16
3.5 Roofs: Concession	16
3.6 Roof lights.....	16
3.7 Internal Columns and Walls: Concession.....	16
3.8 Open Spectator Stands and Indoor Sports Stadiums Concession.....	16
3.9 Carparks: Concessions	17
3.10 Mezzanine Floors: Concession.....	17
4. Type B Fire-Resisting Construction	17
4.1 Fire-resistance of Building Elements	17
4.2 Carparks: Concessions	19
5. Type C Fire-resisting construction	19
5.1 Fire-resistance of Building Elements	19
5.2 Carparks: Concessions	20

1. Scope

This Specification contains requirements for the *fire-resisting construction of building elements*.

2. General Requirements

2.1 Exposure to Fire-source features

A part of a *building element* is exposed to a *fire-source feature* if there is no obstruction to any horizontal line between that part and the *fire-source feature* or a vertical projection of the feature. Where another part of the *building* obstructs any such horizontal line, the part under consideration will still be considered exposed if the obstruction has: an FRL of not less than 30/-/-; or is transparent or translucent.

A part of a *building element* is not exposed to a fire-source feature if the fire-source feature is:

1. an external wall of another building that stands on the allotment and the part concerned is more than 15 m above the highest part of that external wall; or
2. a side or rear boundary of the allotment and the part concerned is below the level of the finished ground at every relevant part of the boundary concerned.

If various distances apply for different parts of a *building element*:

1. the entire element must have the FRL applicable to that part having the least distance between itself and the relevant fire-source feature; or
2. each part of the element must have the FRL applicable according to its individual distance from the relevant fire-source feature,

but this provision does not override or permit any exemption from Clause 2.2.

2.2 Fire protection for a support of another Part

A part of a *building* that gives direct vertical or lateral support to another part *required* to have an FRL, must have an FRL in respect of *structural adequacy* not less than the greater of:

1. that *required* for the part it supports; or
2. that *required* for the part itself,

and be *non-combustible* if the part it supports is *required* to be *non-combustible*.

2.3 Lintels

A lintel must have the FRL *required* for the part of *building* in which it is situated. It need not have the FRL if it does not contribute to the support of a fire door, fire *window* or fire shutter, and:

(a) it spans an opening in:

1. a wall of a *building* containing only one *storey*;
2. a non-loadbearing wall of a Class 2 or 3 *building*; or

(b) it spans an opening in masonry which is not more than 150 mm thick and:

1. not more than 3 m wide if the masonry is *non-loadbearing*; or
2. not more than 1.8 m wide if the masonry is *loadbearing* and part of one of the leaves of a cavity wall.

2.4 Attachments not to impair Fire-resistance

A *combustible* material may be used as a finish or lining to a wall or roof, or in a sign, sunscreen or blind, awning, or other attachment to a *building element* which has the *required* FRL if:

1. the material is exempt under clause 7 of Specification NC1.6 or complies with the Early Fire Hazard Indices prescribed in clause 2 of the same Specification;
2. it is not located near or directly above a *required exit* so as to make the *exit* unusable in a fire; and
3. it does not otherwise constitute an undue risk of fire spread via the facade of the *building*.

The attachment of a facing or finish, or the installation of ducting or any other service, to a part of a *building required* to have an FRL must not impair the *required* FRL of that part.

2.5 General concessions

Steel columns: Except in a *fire wall* or *common wall*, a steel column need not have an FRL in a *building* that contains only one *storey*.

Timber Columns: In a *building* that contains only one *storey* a timber column may be used provided in a *fire wall* or *common wall* the column has the required FRL. In all other cases, the column has an FRL of not less than 30/-/-.

Structures on roofs: A non-*combustible* structure situated on a roof need not comply with the other provisions of this Specification if it only contains one or more of the following:

1. Hot water or other water tanks.
2. Ventilating ductwork, ventilating fans and their motors.
3. Air-conditioning chillers.
4. *Window* cleaning equipment.
5. Other service units that are non-*combustible* and do not contain *combustible* fluids.

3. Type A Fire-resisting Construction

3.1 Fire-resistance of building elements

In a *building* required to be of Type A construction:

- (a) each part mentioned in Table 3, and any beam or column in it, must have an FRL not less than that listed in the Table, for the particular Class of *building* concerned;
- (b) external walls, *common walls*, and floors must be non-*combustible*;
- (c) any *internal wall* required to have an FRL must extend to:
 1. the underside of the floor next above;
 2. the underside of a roof complying with Table 3; or
 3. a ceiling which is immediately below the roof and has a *resistance to the incipient spread of fire* to the roof space of 60 minutes;
- (d) an internal wall is required to be fire-resisting; and
- (e) ventilating, pipe, garbage, or a similar shaft that is not for the discharge of hot products of combustion must be of non-*combustible* construction and, if of lightweight construction, comply with Specification NC1.5;
- (f) any flooring and floor framing in a lift pit must be *non-combustible*; and
- (g) the FRLs specified in Table 3 for an external column apply also to those parts of an internal column that face and are within 1.5 m of a *window* and are exposed through that *window* to a *fire-source feature*.

3.2 Concessions for Floors

The following floors need not comply with clause 3.1:

- (a) A floor laid directly on the ground.
- (b) In a Class 2, 3, 5 or 9 *building*, if the space below is not a *storey*, does not accommodate motor vehicles, is not a storage or work area, and is not used for any other ancillary purpose.
- (c) It is a timber *stage* floor in a Class 9b *building* laid over a floor having the *required* FRL if the space below the *stage* is not used as a dressing room, storeroom, or the like.
- (d) It separates 2 *storeys* within the same *sole-occupancy unit* in a Class 2 *building*.

SECTION NC – FIRE RESISTANCE
Table 3: Type A Construction: FRL of Building Elements

Building element	FRL: (in minutes)		
	Structural adequacy/integrity/insulation		
	Class of building		
	2, 3, or 4 part	5, 6, 7, 8, or 9	
EXTERNAL WALL or other external <i>building element</i> excluding a roof, where the distance from any <i>fire-source feature</i> to which it is exposed is:			
For <i>loadbearing</i> parts:			
	less than 1.5 m	90/90/90	120/120/120
	1.5 to less than 3 m	90/60/60	120/90/90
	3 or more	90/60/30	120/60/30
For <i>non-loadbearing</i> parts:			
	less than 1.5 m	90/90/0	120/120/120
	1.5 to less than 3 m	90/60/60	120/90/90
	3 or more	-/-/	-/-/
EXTERNAL COLUMN not incorporated in an <i>external wall</i> , where the distance from any <i>fire-source feature</i> to which it is exposed:			
	less than 3 m	90/-/	120/-/
	3 m or more	-/-/	-/-/
COMMON WALLS AND FIRE WALL		90/90/90	120/120/120
INTERNAL WALLS			
<i>Fire-resisting lift or stair shafts:</i>			
	Loadbearing	90/90/90	90/90/90
	Non-loadbearing	90/90/90	90/90/90
Bounding <i>public corridors</i> , public hallways and the like:			
	Loadbearing	90/90/90	90/-/
	Non-loadbearing	60/60/60	-/-/
Between or bounding <i>sole-occupancy units:</i>			
	Loadbearing	90/90/90	90/-/
	Non-loadbearing	60/60/60	-/-/
Ventilating, pipe, garbage, and like <i>shafts</i> not used for the discharge of hot products of combustion:			
	Loadbearing	90/90/90	90/90/90
	Non-loadbearing	90/90/90	90/90/90
OTHER LOADBEARING INTERNAL WALLS; AND INTERNAL BEAMS, TRUSSES AND COLUMNS		90/-/	90/-/
FLOORS		90/90/90	120/120/120
ROOFS		90/60/30	120/60/30
MAIN ROOF BEAMS		90/-/	120/-/

3.3 Floor Loading of Class 5 and 9b Buildings: Concession

If a floor in a Class 5 or 9b *building* is designed for a live load not exceeding 3 kPa:

1. the floor next above (including floor beams) may have an FRL, of 90/90/90; or
2. the roof if that is next above (including roof beams) may have an FRL 90/60/30.

3.4 Roof Superimposed on Concrete Slab: Concession

A roof not complying with Clause 3.1 as to *fire-resisting construction* may be superimposed on a concrete slab roof if:

1. the superimposed roof and any construction between it and the concrete slab roof are *non-combustible* throughout; and
2. the concrete slab roof complies with Table 3.

3.5 Roofs: Concession

A roof need not comply with Table 3 if:

(a) in other than a Class 2 or 3 *building*:

1. it has an *effective height* of not more than 25 m and the roof covering and its supporting members are of *non-combustible* construction; or
2. the ceiling immediately below the roof has a resistance to the incipient spread of fire to the roof space of not less than 60 minutes; or
3. the *building* has a *non-combustible* roof covering and the *storey* immediately below the roof has an *automatic sprinkler system* installed throughout; or

(b) in a Class 2 or 3 *building*:

1. all *internal walls* bounding the *sole-occupancy units* on the topmost *storey* extend to the underside of a *non-combustible* roof covering; or
2. the *sole-occupancy unit* is the only unit in that *storey*.

3.6 Roof lights

If a roof is *required* to have an FRL or be *non-combustible*, a roof light installed in that roof must:

(a) have an area not more than 20% of roof surface;

(b) be not less than 3 m from:

1. any boundary of the allotment other than the boundary with a road or public place;
2. any part of the *building* which projects above the roof unless that part has the FRL *required* of a *fire wall* and any openings in the wall are protected in accordance with NC3.4;
3. any roof light in an adjoining *sole-occupancy unit* if the walls bounding the unit are *required* to have an FRL; and
4. any roof light in an adjoining *fire-separated section* of the *building*; and

(c) be installed in a way that will maintain the level of protection to the roof space provided by a required ceiling with a resistance to the incipient spread of fire.

3.7 Internal columns and walls: concession

If under Clause 3.5 a roof that does not have an FRL is used in a *building* with an *effective height* of not more than 25 m, internal columns which are not those referred to in Clause 3.1(f) and load-bearing *internal walls* which are not *fire walls*, in the *storey* immediately below that roof may have an FRL of 60/60/60.

3.8 Open spectator stands and indoor sports stadiums concession

In an *open spectator stand* or indoor sports stadium, the following *building elements* need not have the FRL specified in Table 3:

(a) the roof if it is *non-combustible*;

(b) columns and *loadbearing walls* supporting only the roof if they are *non-combustible*;

(c) any *non-loadbearing* part of an *external wall* less than 3 m:

1. from any fire-source feature to which it is exposed if it has an FRL of not less than 60/60/60 and is *non-combustible*; or
2. from an external wall of another open spectator stand if it is *non-combustible*.

3.9 Carparks: concessions

The FRLs in Table 3.9 apply to a carpark instead of those at Table 3.

Table 3.9: FRL for Carparks

Building element	FRL
Column or beam: less than 4.5 m from a fire-source feature to which it is exposed	60/-/-
Wall: less than 3 m from a fire source feature to which it is exposed	60/60/60
Other steel column: ratio of exposed surface area to mass per unit length not greater than 26 m ² /ton	-/-/-
Any other column (other than a column supporting only the roof)	60/-/-
Fire wall or lift or stair shaft	90/90/90
Any other steel floor beam: which is in continuous contact with a concrete floor slab and has a ratio of exposed surface area to mass per unit length not more than 30 m ² /ton	-/-/-
Any other floor beam	60/-/-
Floor slab or vehicle ramp	60/60/60
Roof and columns supporting only the roof	-/-/-

3.10 Mezzanine floors: concession

Except in a Class 9b *building* which is a spectator viewing area that accommodates more than 100 persons under MD1.13, *mezzanine floors* and any supporting *building elements* need not have an FRL or be *non-combustible* if every wall or column that supports any part of the *building* other than the *mezzanine floor* or floors within 6 m of a *mezzanine floor* has its FRL increased from that otherwise required, as set out in Table 3.10.

Table 3.10: Increased FRLs: Construction Surrounding Mezzanines

Level otherwise required for any FRL criterion (mins)	Increase in level to (not less than):
90	60
60	90
90	120

The increase in level applies to each FRL criterion (*structural adequacy, integrity or insulation*) relevant to the *building element* concerned.

4. Type B Fire-Resisting Construction

4.1 Fire-resistance of Building Elements

In a *building* required to be of Type B construction, each part mentioned in Table 4, and any beam or column in it, must have an FRL not less than that listed:

- in the Table for the particular Class of *building* concerned;
- a *common wall*, the flooring and floor framing in any lift pit, and an external wall where an FRL is listed in Table 4, must be non-combustible;
- if a stair shaft supports any floor or a structural part of it:
 - the floor or part must have an FRL of 60/ - / - or more; or
 - the junction of the stair shaft must be constructed so that the floor or part will be free to sag or fall in a fire without causing structural damage to the shaft.

Table 4: Type B Construction: FRL of Building Elements

Building element	FRL: (in minutes) structural adequacy/integrity/insulation		
	Class of building		
	2, 3, or 4 part	5, 6, 7, 8, or 9	
EXTERNAL WALL or other external <i>building element</i> excluding a roof, where the distance from any <i>fire-source feature</i> to which it is exposed is:			
For <i>loadbearing</i> parts:			
	less than 1.5 m	60/60/60	90/90/90
	1.5 to less than 3 m	60/60/30	90/90/60
	3 or more	60/30/-	90/30/30
For <i>non-loadbearing</i> parts:			
	less than 1.5 m	60/60/60	90/90/90
	1.5 to less than 3 m	60/60/30	90/90/60
	3 or more	-/-/-	-/-/-
EXTERNAL COLUMN not incorporated in an <i>external wall</i> , where the distance from any <i>fire-source feature</i> to which it is exposed:			
	less than 3 m	90/-/-	120/-/-
	3 m or more	-/-/-	-/-/-
COMMON WALLS AND FIRE WALL		90/90/90	120/120/120
INTERNAL WALLS			
Fire-resisting lift or stair shafts:			
	Loadbearing	60/60/60	60/60/60
	Non-loadbearing	60/60/60	60/60/60
Bounding <i>public corridors</i> , public hallways and the like:			
	Loadbearing	60/60/60	60/-/-
	Non-loadbearing	60/60/60	-/-/-
Between or bounding <i>sole-occupancy units</i> :			
	Loadbearing	60/60/60	60/-/-
	Non-loadbearing	60/60/60	-/-/-
OTHER LOADBEARING INTERNAL WALLS; AND INTERNAL BEAMS, TRUSSES AND COLUMNS		60/-/-	60/-/-
FLOORS		60/30/30	60/60/60
MAIN ROOF BEAMS		60/-/-	60/-/-
Note: See NC2.5(d) for Class 9a <i>buildings</i>			

(d) any internal wall which is required to have an FRL must extend to:

1. the underside of the floor next above;
2. the underside of a ceiling having a resistance to the incipient spread of fire to the space above itself of not less than 60 minutes; or
3. the underside of the roof covering if it is non-combustible, or 450 mm above the roof covering if it is combustible, and must not be crossed by timber purlins or other combustible

material,

unless the wall bounds a sole-occupancy unit in the topmost (or only) *storey* and there is only one unit in that *storey*;

- (e) an internal wall required to be fire-resisting must be of non-combustible construction, and if it is of lightweight construction, it must comply with Specification NC1.5;
- (f) lift, ventilation, pipe, garbage, and similar shaft which are not for the discharge of hot products of combustion and not loadbearing, must be of non-combustible construction in Class 2 to 9 *buildings*; and
- (g) all external walls and fire walls within 1.5 m of the boundary, excluding a boundary adjoining a public road or stream or other open water channel, must be extended to not less than 450 mm above the adjoining roof line to form a parapet.

4.2 Carparks: concessions

The FRLs in Table 4.2 apply to a carpark instead of those at Table 4.

Table 4.2: FRL for Carparks

Building element	FRL
Column or beam: less than 4.5 m from a <i>fire-source feature</i> to which it is exposed	60/-/-
Wall: less than 3 m from a <i>fire-source feature</i> to which it is exposed	60/60/60
Other steel column: ratio of exposed surface area to mass per unit length not greater than 26 m ² /ton	-/-/-
Any other column	60/-/-
Fire wall or lift or stair shaft	60/60/60
Any other steel floor beam: which is in continuous contact with a concrete floor slab and has a ratio of exposed surface area to mass per unit length not more than 30 m ² /ton	-/-/-
Any other floor beam	60/-/-

5. Type C Fire-resisting Construction

5.1 Fire-resistance of Building Elements

In a *building* required to be of Type C construction:

- (a) A *building element* listed in Table 5, and any beam or column incorporated in it, must have an FRL not less than that listed in the Table for the particular Class of *building* concerned.
- (b) An *external wall* that is *required* by Table 5 to have an FRL may be considered to have an FRL if the outer part of the wall has the *required* FRL.
- (c) A *fire wall* or an *internal wall* bounding a sole occupancy unit or separating adjoining units, if it is of *lightweight construction*, must comply with Specification NC1.5.
- (d) In a Class 2 or 3 *building*, an *internal wall* which is *required* by Table 5 to have an FRL must extend:
 1. to the underside of the floor next above if that floor has an FRL of at least 30/30/30 or to a fire protective covering on the underside of the floor;
 2. to the underside of a ceiling having a *resistance to the incipient spread of fire* to the space above itself of not less than 60 minutes; or
 3. to the underside of the roof covering if it is *non-combustible*, or 450 mm above the adjoining roof covering if it is *combustible*, and must not be crossed by timber purlins or other *combustible* material,

unless the wall bounds a *sole-occupancy unit* in the topmost (or only) *storey* and there is only one unit in that *storey*.

SECTION NC – FIRE RESISTANCE

- (e) All *external walls* and *fire walls* within 1.5 m of the boundary, excluding a boundary adjoining a public road or stream or other open water channel, must be extended to not less than 450 mm above the adjoining roof line to form a parapet.

Table 5: Type C Construction: FRL of Building Elements

Building element	FRL: (in minutes)			
	Structural adequacy/Integrity/Insulation			
	Class of building			
		2	3 or 4 part	5, 6, 7, 8, or 9
EXTERNAL WALL or other external <i>building element</i> excluding a roof, where the distance from any <i>fire-source feature</i> to which it is exposed is:				
	less than 1.5 m	60/60/60	60/60/60	60/60/60
EXTERNAL COLUMN not incorporated in an <i>external wall</i> , where the distance from any <i>fire-source feature</i> to which it is exposed:				
	less than 1.5 m	60/-/-	60/-/-	90/-/-
COMMON WALLS AND FIRE WALL				
		60/60/60	60/60/60	60/60/60
INTERNAL WALLS				
Bounding <i>public corridors</i> , public hallways and the like:				
		30/30/30	60/60/60	-/-/-
Between or bounding <i>sole-occupancy units</i>				
		30/30/30	60/60/60	-/-/-
Bounding a Stair if required to be rated				
		30/30/30	60/60/60	-/-/-
Note: See NC2.5(d) for floors of Class 9a <i>buildings</i>				

5.2 Carparks: concessions

The FRLs in Table 5.2 apply to a carpark instead of those at Table 5.

Table 5.2: FRLs for Carparks

Building element	FRL
Column or beam: less than 1.5 m from a <i>fire-source feature</i> to which it is exposed	60/-/-
Wall: less than 1.5 m from a <i>fire-source feature</i> to which it is exposed	60/-/-
Other steel column: ratio of exposed surface area to mass per unit length not greater than 26 m ² /ton	-/-/-
Any other column	60/-/-
Any other steel floor beam: which is in continuous contact with a concrete floor slab and has a ratio of exposed surface area to mass per unit length not more than 30 m ² /ton	-/-/-
Any other floor beam	60/-/-

SPECIFICATION NC1.5

Structural Tests for Lightweight Construction

Contents

1. Scope	21
2. Definition	21
3. Application	21
4. Test methods.....	21
5. Test specimens	22
6. Criteria of compliance	22
7. Wall systems	23
8. Construction bounding means of egress.....	23
9. Requirements for certain Class 9b buildings.....	23
10. Lift Shafts	23

1. Scope

This Specification contains the tests to be applied and criteria to be satisfied by *lightweight construction*.

2. Definition

Lightweight construction is:

(a) *fire-resisting construction* which:

1. is not in continuous contact with the principal construction that it protects from fire; or
2. is of sheet or board material, plaster, render, sprayed application, or other material similarly susceptible to damage by pressure or abrasion;

(b) *fire-resisting construction* that incorporates or comprises:

1. concrete containing pumice, perlite, vermiculite, or other soft material; or
2. masonry having a thickness less than 70 mm.

3. Application

The tests prescribed in this Specification apply to construction other than concrete or masonry which need not be tested in accordance with this Specification if it is designed:

- (a) in accordance with this Code; and
- (b) to resist, as serviceability loads, the appropriate pressure and impact defined in this Specification.

4. Test methods

Tests must be carried out in accordance with the following:

- (a) **Materials tests:** in accordance with the methods specified for the constituent materials of construction in the Standards adopted by reference in this Code.

- (b) **For resistance to static pressure:** The provisions for testing walls under transverse load in ASTM E72-22, except that:
1. the chamber method must not be used;
 2. the load must be applied dynamically at a frequency not less than 1 Hz and not more than 3 Hz; and
 3. it is sufficient to test one specimen with the pressure applied from the side of the construction on which the lift will operate.
- (c) **For resistance to impact:** The provisions for testing wall systems in ASTM E695-03, except that:
1. the points of impact must be set at 1.5 m above finished floor level or 1.5 m above the part of the specimen that corresponds to finished floor level; and
 2. the diameter of the impact bag must be between 225 mm and 260 mm and the bag must weigh $27.2 + 0.1$ kg;
 3. the mass must be achieved by putting loose, dry sand into the bag and must be adjusted before each series of impact tests; and
 4. the method may be used also for wall that depart from the vertical or that are curved and in cases where the pendulum bag and suspension cannot be vertical at the instant of impact on a concave surface or a surface inclined towards the impact, the height of drop is the net height at the point of impact.
- (d) **For resistance to surface indentation:** for all materials irrespective of composition: AS 2185.
- (e) **For resistance of lift shaft construction to repetitive load:** as for 3(b) except that:
1. the load must be applied dynamically at a frequency not less than 1 Hz and not more than 3 Hz; and
 2. it is sufficient to test one specimen with the pressure applied from the
 3. side of the construction on which the lift will operate.

5. Test Specimens

Tests must be carried out on construction *in situ* or on specimens of the construction in accordance with clause 4 except that:

1. test specimens of the construction must be supported at top and bottom (or at each end if tested horizontally by components identical with, and in a manner identical with, the actual construction); and
2. the heights of the test specimens (or lengths, if the specimens are tested horizontally) must be identical with the height between those supports in the actual construction.

6. Criteria of Compliance

The following criteria must be adopted to determine compliance with the specification:

- (a) **Material:** Must comply with the applicable Standard adopted by reference in this Code.
- (b) **Damage:** The construction must show no crack, penetration or permanent surface- deformation to a depth of more than 0.5mm nor must there be any other non-elastic deformation nor fastener failure.
- (c) **Deflection: Static pressure:** Under static pressure the deflection of the construction must not be more than:
1. $1/240$ of the height between supports (the span of the construction as tested);
 2. 30 mm; or
 3. 20 mm for lift *shafts* unless the requirements of Clause 15.2(a) of AS 1735.2 are fulfilled.
- (d) **Deflection: Impact:** Under impact the instantaneous deflection of the construction must not be more than:
1. $1/120$ of the height between supports (the span of the construction as tested);
 2. 30 mm; or
 3. 20 mm for lift *shafts* unless the requirements of clause 15.2(a) of AS 1735.2 are fulfilled.
- (e) **Surface indentation (AS 2185):** No impression must be more than 5 mm in diameter.

7. Wall Systems

Wall systems that are *required* to be *fire-resisting* bounding *public corridors*, public hallways and the like, and between or bounding *sole-occupancy units* must be subjected to the following tests and must fulfill the following criteria:

1. the materials tests of clause 4(a) and the materials properties criteria of clause 6(a);
2. a static test by the imposition of a uniformly distributed load (or its equivalent) of 0.25k Pa in accordance with clause 4(b) and the damage and deflection criteria of clauses 6(b) and (c) respectively;
3. a dynamic test by the imposition of the impact of the impact bag falling through a height of 100 mm in accordance with clause 4(c) and the damage and deflection criteria of clause 6(b) and (d) respectively; and
4. the surface indentation test of clause 4(d) and the surface indentation criterion of clause 6(e).

8. Construction Bounding Means of Egress

Construction bounding means of egress including wall systems for use in-lift *shafts*, stair *shafts*, *fire-isolated passageways* and *fire-isolated ramps* that are *required* to be *fire-resisting* must be subjected to the following tests and must fulfill the following criteria:

1. the materials tests of clause 4(a) and the materials properties criteria of clause 6(a);
2. a static test by the imposition of a uniformly distributed load (or its equivalent) or 0.35 kPa in accordance with clause 4(b) and the damage and deflection criteria of clauses 6(b) and (c) respectively;
3. a dynamic test with the impact bag falling through a height of 150 mm in accordance with clause 3(c) and the damage and deflection criteria of clause 6(b) and (d) respectively; and
4. the surface indentation test of clause 4(d) and the surface indentation criterion of clause 6(e).

9. Requirements for certain Class 9b buildings.

Wall systems for use in spectator stands, sports stadia, cinemas or theaters, railway or bus station, or airport terminals in:

- (a) lift *shafts* or stair *shafts*;
- (b) external and *internal walls* bounding *public corridors*, public hallways and the like, including fire-isolated and non-*fire-isolated passageways* or ramps, must be subjected to the following tests and must fulfill the following criteria:
 1. The materials tests of clause 4(a) and the materials properties criteria of clause 6(a);
 2. A static test by the imposition of a uniformly distributed load (or its equivalent) of 1.0 kPa in accordance with Clause 4(b) and the damage and deflection criteria of clauses 6(b) and (c) respectively;
 3. A dynamic test with the impact bag falling through a height of 350 mm in accordance with Clause 4(c) and the damage and deflection criteria of clauses 6(b) and (d) respectively; and
 4. The surface indentation test of clause 4(d) and the criterion of clause 6(e).

10. Lift Shafts

In addition to the requirements of Clauses 8 and 9, *wall systems* for use in lift *shafts* that are *required* to be *fire-resisting* must be subjected to dynamic test by the imposition of 10 million cycles of a uniformly distributed load (or its equivalent) between 0 and 0.35 kPa in accordance with clause 4(e) and must fulfill the damage criteria of clause 6(b).

SPECIFICATION NC1.6

Early Fire Hazard Indices

Contents

1. Scope	24
2. Class 2 to 9 buildings: General requirements	24
3. Fire-isolated exits	24
4. Class 2,3 and 9 buildings: Public areas	25
5. Acceptable materials	25
6. Fire-retardant coatings	25
7. Exempted building parts and materials	25

1. Scope

This Specification sets out requirements in relation to the Early Fire Hazard Indices of materials, linings and surface finishes inside *buildings*.

2. Class 2 to 9 Buildings: General Requirements

Except where superseded by clause 3 or 4, any material or component used in a Class 2, 3, 5, 6, 7, 8, or 9 *building* must:

- (a) in the case of a *sarking-type material*, have a *Flammability Index* not more than 5;
- (b) in the case of other materials, have:
 - 1. a *Spread-of-Flame Index* not more than 9; and
 - 2. a *Smoke-Developed Index* not more than 8 if the *Spread-of-Flame Index* is more than 5;
- (c) be completely covered on all faces by concrete or masonry not less than 50 mm thick; or
- (d) in the case of a composite member or assembly, be constructed so that when assembled as proposed in a *building*:
 - 1. any material which does not comply with (a) or (b) is protected on all sides and edges from exposure to the air;
 - 2. the member or assembly, when tested in accordance with Specification A2.4, has a *Smoke-Developed Index* and a *Spread-of-Flame Index* not exceeding those prescribed in (b); and
 - 3. the member or assembly retains the protection in position so that it prevents ignition of the material and continues to screen it from access to free air for a period of not less than 10 minutes.

3. Fire-isolated Exits

In a *fire-isolated stairway*, *fire-isolated passageway*, or *fire-isolated ramp* in a Class 2 to 9 *building*:

- (a) a *material*, other than a *sarking-type material*, used in a ceiling, as an attachment to a *structural member* or as the finish, surface or lining of a *structural member* must:
 - 1. have a *Spread-of-Flame Index* of 0;
 - 2. have a *Smoke-Developed Index* of not more than 2; and
 - 3. if combustible, be attached directly to a non-combustible substrate and not exceed 1 mm in finished thickness;

- (b) a *sarking-type* material used in the form of an exposed wall or ceiling, or as a finish or attachment thereto, must have a *Flammability Index* of 0.

4. Class 2, 3, and 9 Buildings: Public Areas

A material other than a *sarking-type material* must have a *Spread-of-Flame Index* of 0 and a *Smoke-Developed Index* not more than 5 if it is used:

- (a) in a Class 2, 3, 9a, or 9b *building*: as a finish, surface, lining or attachment to any wall or ceiling in an internal *public corridor*, hallway, or the like, which is a means of egress to:
1. a stairway *required* to be fire- isolated or an external stairway used instead; or
 2. a passageway, or ramp, *required* to be fire-isolated; or
- (b) in a class 9b *building* which is used as a theatre, public hall, or the like:
1. as a finish, surface, lining, or attachment to any ceiling, wall or floor;
 2. as the covering of fixed seating in the audience seating area; or
 3. in a cinema projection room.

5. Acceptable Materials

A material complies with clauses 2, 3, or 4 if it is:

1. plaster, cement render, concrete, terrazzo, ceramic tile or the like; or
2. a fire-protective covering.

6. Fire-retardant Coatings

When paint or fire-retardant coatings are used in order to make a substrate comply with a *required Spread-of-Flame Index*, *Smoke-Developed Index* or *Flammability Index*, this fact must be clearly marked on an easily visible label or labels and permanently fixed to the *building element* so that the coating will not be scraped off or otherwise made ineffective, without recoating to preserve the fire-retardant properties. If any coating used will retain the *required* fire-retardant properties for only a limited period, it must be replaced before the expiry of such period so that the *required* properties are not diminished.

7. Exempted Building Parts and Materials

The requirements in this Specification for a *Spread-of-Flame Index*, *Smoke-Developed Index* or *Flammability Index* do not apply to:

- (a) timber-framed *windows*;
- (b) solid timber handrails or skirtings;
- (c) timber-faced solid-core or fire doors;
- (d) electrical switches, outlets, cover plates or the like;
- (e) materials used for:
1. roof covering or membranes, or roof insulating material, applied in continuous contact with a substrate;
 2. adhesives; or
 3. damp-proof courses, flashings, caulking, sealing, ground moisture barriers, or the like;
- (f) paint, varnish, lacquer or similar finish, other than nitro-cellulose lacquer;
- (g) a clear or translucent rooflight of glass fiber-reinforced polyester if:
1. the roof in which it is installed forms part of a *building* in Type C construction;
 2. the material is used as part of the roof covering;
 3. it is not prohibited by any other clause of this Code;
 4. it is not closer than 1.5 m from another rooflight of the same type;
 5. each rooflight is not more than 14 m² in area; and
 6. the area of the rooflights is not more than 20% of roof surface; or
- (h) any other material which does not significantly increase the hazards of fire.

SPECIFICATION NC3.4

Fire Doors, Smoke Doors, Fire Windows & Shutters

1. Scope

This Specification sets our requirements for the construction of fire doors, smoke doors, fire *windows*, and fire shutters.

2. Fire Doors

A *required* fire door must comply with NZS 4232 or AS 1905.1, except that:

- (a) it may be fully glazed or incorporate glazing if the tested prototype was similarly glazed;
- (b) the radiation level at a distance of 365 mm from the face of the glazing must not exceed 10 kW/m² during the period corresponding to that for *insulation* in the *required* FRL;
- (c) the rise in average temperature on the side of the tested prototype remote from the furnace must not exceed 140°C (except in any glazed part) during the first 30 minutes of the fire test.

2. Smoke Doors

A *required* smoke door:

- (a) may have 1 or 2 door leaves;
- (b) must swing:
 - 1. in the direction of egress; or
 - 2. in both directions if the path of travels to *exits* is in either direction;
- (c) must be *self-closing* and may be fitted with an *automatic* release device; and
- (d) must be constructed of:
 - 1. solid-core timber at least 35 mm thick, glazed panels in a timber frame at least 35 mm thick, or a metal frame, with a mid-rail or suitable crash bar; or
 - 2. PVC, or other suitable material;
 - 3. and if necessary, be fitted with smoke seals.

3. Fire shutters

A *required* fire shutter must:

- (a) be a shutter that:
 - 1. is identical with a tested prototype that has achieved the *required* FRL;
 - 2. is installed in the same manner and in an opening that is not larger than the tested prototype; and
 - 3. did not have a rise in average temperature on the side remote from the furnace of more than 140°C during the first 30 minutes of the test; or
- (b) is a steel shutter complying with NZS 4232 or AS 1905.1 if a metallic fire shutter is not prohibited by NC3.5.

4. Fire Windows

A *required* fire *window* must be:

- (a) identical in construction with a prototype that has achieved the *required* FRL; and
- (b) installed in the same manner and in an opening that is not larger than the tested prototype.

SPECIFICATION NC3.15

Penetration of Walls, Floors & Ceilings by Services

1. Scope	27
2. Application	27
3. Metal pipes.....	27
4. Pipes penetrating sanitary compartments	27
5. Wires and cables	28
6. Electrical switches and outlets.....	28
7. Fire-stopping	28

1. Scope

This Specification prescribes materials and methods of installation for services that penetrate walls, floors, and ceilings *required* to have an FRL.

2. Application

This Specification applies to installations permitted under this Code as alternatives to systems that have been demonstrated by test to fulfill the requirements of NC3.14.

This Specification does not apply to installations in ceilings *required* to have a *resistance* to the incipient spread of fire not to the installation of piping that contains or is intended to contain a flammable liquid or gas.

3. Metal Pipes

- (a) A metal pipe that is not normally filled with liquid must not penetrate a wall, floor, or ceiling within 100 mm of any *combustible* material unless wrapped or fire stopped to satisfy the requirements of Clause 7, and must be constructed of:
 1. copper alloy or stainless steel with a wall thickness of at least 1 mm; or
 2. cast iron or steel (other than stainless steel) with a wall thickness of at least 2 mm.
- (b) An opening for a metal pipe must:
 1. be neatly formed, cut or drilled;
 2. be no closer than 200 mm to any other service penetration; and
 3. accommodate only one pipe
- (c) A metal pipe must be wrapped but must not be lagged or enclosed in thermal insulation over the length of its penetration of a wall, floor or ceiling unless the lagging or thermal insulation fulfills the requirements of Clause 7.
- (d) The gap between a metal pipe and the wall, floor or ceiling it penetrates must be fire-stopped in accordance with Clause 7.

4. Pipes Penetrating Sanitary Compartments

If a pipe of metal or UPVC penetrates the floor of a *sanitary compartment* in accordance with NC3.15(e) of this Code:

- (a) the opening must be neatly formed and no larger than is necessary to accommodate the pipe or fitting; and
- (b) the gap between pipe and floor must be fire-stopped in accordance with Clause 7.

5. Wires and Cables

If a wire or cable or cluster of wires or cables penetrates a floor, wall, or ceiling:

- (a) the opening must be neatly formed, cut or drilled and no closer than 50 mm to any other service opening; and
- (b) the opening must be no larger in cross-sectional area than:
 - 1. 2,000 mm² if only a single cable is accommodated and the gap between cable and wall, floor or ceiling is no wider than 15 mm; or
 - 2. 500 mm² in any other case; and
- (c) the gap between the service and the wall, floor or ceiling must be fire-stopped in accordance with Clause 7.

6. Electrical switches and outlets

If an electrical switch, outlet, socket or the like is accommodated in an opening or recess in a wall, floor or ceiling:

- (a) the opening or recess must not:
 - 1. be located opposite any point within 300 mm horizontal nor 600 mm vertically of any opening or recess on the opposite side of the wall; or
 - 2. extend beyond half the thickness of the wall; and
- (b) the gap between the service and the wall, floor or ceiling must be *fire-stopped* in accordance with Clause 7.

7. Fire-stopping

- (a) **Material:** The material used for fire-stopping of service penetrations must be in accordance with AS 4072.1 concrete, high-temperature mineral fiber, high-temperature ceramic fiber, or other material that does not flow at a temperature below 1,120°C when tested in accordance with AS 1038.15, and must have:
 - 1. demonstrated in a system tested in accordance with NC3.15(a) of this Code that it does not impair the *fire-resisting* performance of the *building element* in which it is installed; or
 - 2. demonstrated in a test in accordance with (e) that it does not impair the *fire-resisting* performance of the test slab.
- (b) **Installation:** Fire-stopping material must be packed into the gap between the service and wall, floor or ceiling in a manner, and compressed to the same degree, as adopted for testing under 7(a) (i) or (ii).
- (c) **Hollow construction:** If a pipe penetrated a hollow wall (such as a stud wall, a cavity wall or a wall of hollow blockwork) or a hollow floor/ceiling system, the cavity must be so framed and packed with fire-stopping material that the material is:
 - 1. installed in accordance with 7(b) to a thickness of 25 mm all around the service for the full length of the penetration; and
 - 2. restrained, independently of the service, from moving or parting from the surfaces of the service and of the wall, floor, or ceiling.
- (d) **Recesses:** If an electrical switch, socket, outlet or the like is accommodated in a recess in a hollow wall or hollow floor/ceiling system:
 - 1. the cavity immediately behind the service must be framed and packed with fire-stopping material in accordance with 7(c); or
 - 2. the back and sides of the service must be protected with refractory lining board identical with and to the same thickness as that in which the service is installed.
- (e) **Test:** The test to demonstrate compliance of a fire-stopping material with this Specification must be conducted as follows:

SECTION NC – FIRE RESISTANCE

1. The test specimen must comprise a concrete slab not less than 1 m² and not more than 100 mm thick, and appropriately reinforced if necessary for *structural adequacy* during manufacture, transport, and testing.
2. The slab must have a hole 50 mm in diameter through the center and the hole must be packed with the fire-stopping material.
3. The slab must be conditioned in accordance with AS 1530.4.
4. Two thermocouples complying with AS 1530.4 must be attached to the upper surface of the packing each about 5mm from its center.
5. The slab must be tested on flat generally in accordance with Section 10 of AS 1530.4.

Section

ND

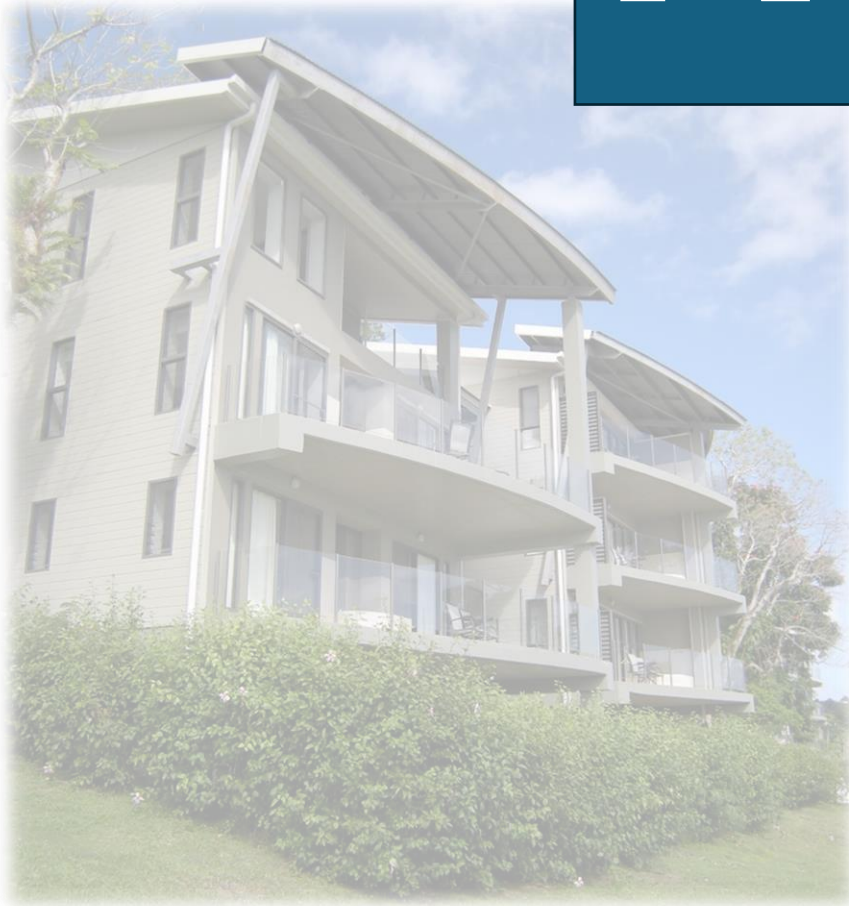

ACCESS & EGRESS

THIS SECTION APPLIES TO PUBLIC
BUILDINGS AND GROUP DWELLINGS

(CLASS 2 to CLASS 9)

Contents

PERFORMANCE REQUIREMENTS	1
OBJECTIVES	1
NDP1 Provision for Escape	1
NDP2 Construction of Exits.....	1
NDP3 Access for People with Disabilities	1
REQUIRED PERFORMANCE	1
DEEMED-TO-SATISFY PROVISIONS	1
ND1 Provision for Escape	1
ND1.1 Application	1
ND1.2 Number of Exits Required	1
ND1.3 When Smoke or Fire-isolated Exits are Required.....	1
ND1.4 Exit Travel Distances	2
ND1.5 Distance Between Alternative Exits.....	2
ND1.6 Dimensions of Exits.....	2
ND1.7 Travel via Smoke or Fire-isolated Exits	3
ND1.8 External Stairways.....	3
ND1.9 Travel by Non-fire-isolated Stairways or Ramps.....	4
ND1.10 Discharge from Exits	4
ND1.11 Horizontal Exits	4
ND1.12 Non-required Stairways or Ramps	5
ND1.13 Number of Persons Accommodated	5
ND1.14 Measurement of Distances.....	7
ND1.15 Method of Measurement	7
ND 1.16 Emergency Exit Preparedness	8
ND2 Construction of Exits	8
ND2.1 Application of Part	8
ND2.2 Fire-isolated stairways and ramps	8
ND2.3 Non-fire-isolated stairways and ramps	8
ND2.4 Separation of rising and descending stair flights.....	8
ND2.5 Open access ramps and balconies	8
ND2.6 Smoke lobbies	9
ND2.7 Installations in exits and paths of travel	9

ND2.8 Enclosure of space under fire-isolated stairs and ramps.....	9
ND2.9 Width of Stairways	9
ND2.10 Ramps	10
ND 2.10.1 Pedestrian ramps.....	10
ND2.10.2 Service ramps.....	10
ND2.11 Fire-isolated passageways	11
ND2.12 Roof as open space	11
ND2.13 Treads and risers.....	11
ND2.13.1 Straight Flights.....	11
ND2.13.2 Curved Stairs.....	12
ND2.14 Landings	12
ND2.15 Thresholds.....	13
ND2.16 Balustrades	13
ND2.17 Handrails	14
ND2.18 Fixed platforms, walkways and ladders.....	14
ND2.19 Doorways and doors	14
ND2.20 Swinging doors.....	15
ND2.21 Operation of Latch	15
ND2.22 Re-entry from fire-isolated exits	16
ND3 Access for People with Disabilities	16
ND3.1 Application of Part	16
ND3.2 Access to Buildings.....	16
ND3.3 Parts of buildings to be accessible.....	17
ND3.4 Common Building Elements	17
ND 3.5 Evacuation Plans.....	18
ND 3.6 Accessible Car Parking.....	18

PERFORMANCE REQUIREMENTS

OBJECTIVES

A *building* must be so designed and constructed that the following objectives are fulfilled:

NDP1 Provision for Escape

There must be adequate means of escape in case of fire or other emergency from all parts of the *building* to a place of safety.

NDP2 Construction of Exits

- (a) Stairways, ramps, and passageways must be such as to provide safe passage for the users of the *building*.
- (b) Stairways and ramps must not be uncomfortable or strenuous to use.
- (c) Stairways, ramps, floors and balconies, and any roof to which people normally have access, must have bounding walls, balustrades or other barriers where necessary to protect users from the risk of falling.
- (d) Vehicle ramps and any floor to which vehicles have access must have kerbs or other barriers where necessary to provide protection to pedestrians and to the structure of the *building*.

NDP3 Access for People with Disabilities

Reasonable provision must be made in the design of a *building*, having regard to its use and location, to facilitate access and circulation by people with disabilities.

REQUIRED PERFORMANCE

NDP1.1 The design and construction of *buildings* must allow all occupants in any or all *fire compartments* to get to:

- (a) any one of more than one exit within 2.5 minutes; or
- (b) in the case of *buildings* with 3 or fewer stories or a basement of less than 50 m² floor area, to a single exit within 1 minute.

NDP2.1 The design and construction of *exits* must allow for the following optimum conditions during evacuation in any emergency:

- (a) a density in the *exit* of 2.0 persons/ m² of *exit floor area*
- (b) a speed of movement along the slope of the *exit* of 0.5 m/s; and
- (c) an average flow of 1.18 persons per second per meter effective width of *exit*.

In the case of occupancies such as hospitals where evacuation needs the assistance of others and/or of equipment, additional consideration must be given to the design of *exits*.

The *pitch* of any stairway or slope of a ramp must not be unsafe or uncomfortable.

The size of openings in any bounding wall, balustrade, or the like must be such as to prevent very young mobile children from going through them and injuring themselves. These must also be designed to discourage young children under 5 years of age from gaining any foothold and climbing over them.

NDP3.1 People with disabilities must have the facility to gain reasonable access to *buildings* so that they are not at any material disadvantage when compared with others.

DEEMED-TO-SATISFY PROVISIONS

ND1 Provision for Escape

ND1.1 Application

This Part applies to all *buildings* except the internal parts of a *sole-occupancy unit* in a Class 2 or 3 *building* or Class 4 part.

ND1.2 Number of Exits Required

- (a) **All buildings:** Every *building* must have at least one *required exit*. The *required exit* must be *accessible* by people with disabilities and should incorporate *tactile ground surface indicators* (TGSIs) at stairways and ramps to guide individuals with visual impairments.
- (b) **Class 2 to 8 buildings:** In addition to any *horizontal exit*, not fewer than two *exits* must be provided from each *storey* if the *building* has a rise of three or more *storeys* or an *effective height* of more than 10 m.
- (c) **Basements:** In addition to any *horizontal exit*, not fewer than 2 *exits* must be provided from any *storey* if egress from that *storey* involves an upward vertical climb within the *building* of more than 1.5 m, unless:
 - 1. in addition to a single *exit* other than a *horizontal exit*, one or more openable or easily breakable *windows* or other openings are available, in which case the top of the sill must be no higher than 1.5 m from the floor level of the room. In addition, the *windows* or openings must have one clear dimension of at least 600 mm and a minimum opening of 0.6 m². The *windows* or openings must be clear of any surrounding ground by at least 1 m horizontally and the vertical drop from the sill to the ground outside, no more than 2 m; or
 - 2. the area of the *storey* is not more than 50 m² as well as the distance of travel from any point on the floor to a single *exit*, not more than 20 m.
- (d) **Class 9 buildings:** In addition to any *horizontal exit* and subject to (e) and (f), not fewer than 2 *exits* must be provided from:
 - 1. each *storey* if the *building* has a rise of three or more *storeys* or an *effective height* of more than 10 m;
 - 2. any *storey* which includes a ward area in a Class 9a *building*;
 - 3. each *storey* in a Class 9b *building* used as an early childhood center; and
 - 4. any *storey* or mezzanine that accommodates more than 100 persons, calculated under ND1.13.
- (e) **Exits from divided wards:** In a Class 9a *building*, at least one *exit* must be provided from every portion of a *storey* which has been divided in accordance with NC2.5.
- (f) **Exits in open spectator stands:** In an *open spectator stand* containing more than one tier of seating, every tier must have not fewer than 2 stairways or ramps, each forming part of the path of travel to not fewer than 2 *exits*.

ND1.3 When Smoke or Fire-isolated Exits are Required

Every *required exit* other than an external stairway or open ramp must be:

- (a) smoke-isolated to the relevant requirements of ND2.6(b) and (c) if it connects 3 or more consecutive stories; and
- (b) fire-isolated if it connects 5 or more consecutive stories.

Exception: These requirements do not apply to *exits* that form part of an *open spectator stand*.

ND1.4 Exit Travel Distances

- (a) Class 2 and 3 buildings and class 4 parts:
1. The entrance doorway of any *sole-occupancy unit* must be not more than 6 m from an *exit* or from a point at which travel in different directions to 2 *exits* is available. Further, the route of travel within the unit from any point other than from a kitchen or cooking area to the doorway must not traverse through a kitchen or cooking area; and
 2. no point on the floor of a room which is not in a *sole-occupancy unit* must be more than 20 m from an *exit* or from a point at which travel in different directions to 2 *exits* is available, in which case the maximum distance to one of those *exits* must not exceed 40 m from the starting point.
- (b) Class 5 to 9 buildings subject to (c), (d), and (e):
1. No point on a floor must be more than 20 m from an *exit*, or a point from which travel in different directions to 2 *exits* is available, in which case the maximum distance to one of those *exits* must not exceed 40 m from the starting point.
 2. In a Class 5 or 6 *building*, the distance to a single *exit* serving at the level of access to a road or *open space* may be increased to 30 m.
- (c) **Class 9a buildings** in a *ward area* in a Class 9a *building*:
1. no point on the floor must be more than 12 m from a point from which travel in different directions to 2 of the *required exits* is available; and
 2. the maximum distance to one of those *exits* must not be more than 30 m from the starting point.
- (d) **Open spectator stands**: The distance of travel to an *exit* in a Class 9b *building* used as an *open spectator stand* must be not more than 60 m.
- (e) **Assembly buildings** in a Class 9b *building* other than a *school* or *early childhood center*, the distance to one of the *exits* may be 60 m if:
1. the path of travel from the room concerned to that *exit* is through another area which is a corridor, hallway, lobby, ramp, or other circulation space;
 2. the room is smoke-separated from the circulation space by construction such that:
 - any wall is *non-combustible* and extends to the underside of the floor above or of the roof covering; and
 - it only has doorways with smoke doors that comply with Specification NC3.4 and do not extend higher than 800 mm from the underside of an imperforate roof covering, floor, or ceiling above it; and
 3. the maximum distance of travel does not exceed 40 m within the room and 20 m from the doorway to the room through the circulation space to the *exit*.

ND1.5 Distance Between Alternative Exits

Exits that are *required* as alternative means of egress must be:

- (a) distributed as uniformly as practicable within or around the *storey* served;
- (b) not less than 9 m apart; and
- (c) not more than:
1. 45 m apart in a Class 2 or 3 *building* or a *storey* containing a *ward area* in a Class 9a *building*; or
 2. 60 m apart in all other cases.

ND1.6 Dimensions of Exits

In a *required exit* or path of travel to an *exit*:

- (a) the unobstructed height throughout must be not less than 2 m;
- (b) if the *storey* or mezzanine pertains to a Class 2 or 3 *buildings* or accommodates not more than 100 persons, the unobstructed width except for doorways must be:
1. not less than 1 m; or
 2. 2 m in a passageway from a *ward area*;

SECTION ND – ACCESS AND EGRESS

- (c) if the *storey* or mezzanine accommodates more than 100 persons and not more than 200 persons, the aggregate width, except for doorways, must be not less than:
 - 1. 1 m plus 250 mm for each 25 persons (or part) in excess of 100; or
 - 2. 2 m in a passageway from a *ward area* in class 9a *buildings*;
- (d) if the *storey* or mezzanine accommodates more than 200 persons, the aggregate width, except for doorways, must be increased to:
 - 1. 2 m plus 500 mm for every 60 persons (or part) in excess of 200 persons if egress involves a change in floor level by a stairway or ramp with a gradient more than 1:12; or
 - 2. in any other case, 2 m plus 500 mm for every 75 persons (or part) in excess of 200;
- (e) in an *open spectator stand* which accommodates more than 2000 persons the width except for doorways must be increased to 17 m plus a width (in meters) equal to the number in excess of 2000 divided by 600;
- (f) the clear openings of a doorway must be not less than:
 - 1. in *ward areas*: 1.6 m wide or 1.25 m if it is a *horizontal exit*;
 - 2. in areas used by students in a *school*: 870 mm wide;
 - 3. the width of *exit required* by (b), (c), (d) or (e), minus 250 mm; or
 - 4. in any other case except where it opens to a *sanitary compartment* or bathroom: -760 mm wide; and
- (g) the *required* width of *exit* must not diminish in the direction of travel to a road or *open space*.

ND1.7 Travel via Smoke or Fire-isolated Exits

- (a) A doorway from a room must not open directly into a stairway, passageway or ramp that is *required* to be smoke or fire-isolated unless it is from:
 - 1. a public lobby, *public corridor*, hallway, or the like;
 - 2. a *sole-occupancy unit* occupying all of a *storey*; or
 - 3. a *sanitary compartment*, airlock, or the like.
- (b) Each stairway or ramp that is *required* to be smoke or fire isolated must provide independent egress from the *storey* served and discharge:
 - 1. directly, or by way of a *fire-isolated passageway*, to a road or *open space*; or
 - 2. into a *storey* or space within the confines of the *building* that is enclosed for not more than 1/3 of its perimeter and used only for pedestrian movement, car parking, or the like, to a point where an unimpeded path of travel not further than 20 m is available to a road or *open space*.
- (c) if more than 2 access doors, other than from a *sanitary compartment* or the like, open to a fire-isolated *exit* in the same *storey*:
 - 1. a smoke lobby in accordance with ND2.6 must be provided; or
 - 2. the *exit* must be pressurized in accordance with NE2.7.
- (d) A ramp must be provided at any change in level less than 600 mm in a fire-isolated passageway in a Class 9 *building*.

ND1.8 External Stairways

An external stairway may serve as a *required exit* instead of a smoke isolated or *fire-isolated stairway* in a *building* with an *effective height* of not more than 25 m if the stairway (including any connecting bridges) is of *non-combustible* construction throughout.

If any part of the stairway is exposed to, and less than 4 m from, a *window*, doorway or the like in an external wall, the stairway must be fully shielded in the affected area from such *window* or doorway by *non-combustible* construction with an FRL of not less than 60/60/60.

If any part of the stairway is exposed to, and less than 4 m but more than 3 m from, a *window*, doorway or the like in an *external wall* of any *building*, the *window* doorway or the like must be protected in accordance with NC3.4.

External stairways should be equipped with non-slip surfaces, handrails on both sides, and tactile indicators to enhance safety and usability for all individuals, including those with vision impairments or mobility challenges.

ND1.9 Travel by Non-fire-isolated Stairways or Ramps

- (a) A *non-fire-isolated stairway* serving as a *required exit* must provide a continuous means of travel by its own flights of stairs and landings from every *storey* served to the level at which egress to a road or *open space* is provided.
- (b) In a Class 2, 3 or 4 *building*, the distance between the doorway of a room or *sole-occupancy unit* and the point of egress to a road or *open space* by way of any *required* stairway or ramp that is not fire-isolated must not exceed:
 - 1. 30 m in a *building* of Type G construction; or
 - 2. 60 m in all other cases.
- (c) In a Class 5 to 9 *building*, the distance from any point on a floor and a point of egress to a road or *open space* by way of a *required non-fire-isolated stairway* or ramp must not exceed 80 m.
- (d) In a Class 2, 3 or 9a *building*, a *required non-fire-isolated stairway* or ramp must discharge at a point not more than:
 - 1. 15 m from a doorway providing egress to a road or *open space* or from a *fire-isolated passageway* leading to a road or *open space*; or
 - 2. 30 m from one of 2 such doorways or passageways if travel to each of them from the stairway or ramp is in opposite or approximately opposite directions.
- (e) In a Class 5 to 8 or 9b *building*, a *required non-fire-isolated stairway* or ramp must discharge at a point not more than:
 - 1. 20 m from a doorway providing egress to a road or *open space* or from a *fire-isolated passageway* leading to a road or *open space*; or
 - 2. 40 m from one of two such doorways or passageways if travel to each of them from the stairway or ramp is in opposite or approximately opposite directions.
- (f) If 2 or more *exits* are *required* and are provided by means of internal *non-fire-isolated stairways* or *non-fire isolated ramps*, each *exit* must:
 - 1. provide separate egress to a road or *open space*; and
 - 2. be suitably smoke-separated from each other at the level of discharge.

ND1.10 Discharge from Exits

- (a) An *exit* must not be blocked at the point of discharge and where necessary, suitable barriers must be provided to prevent vehicles from blocking the *exit*, or access to it.
- (b) If a *required exit* leads to an *open space*, the path of travel to the road must have an unobstructed width throughout of not less than:
 - 1. the minimum width of the *required exit*; or
 - 2. 1 m; whichever is the greater.
- (c) If an *exit* discharges to *open space* that is at a level different from the public road to which it is connected, the path of travel to the road must be by:
 - 1. a ramp or other incline having a grade of not more than 1:8 at any part, or 1:14 if *required* by Part ND3; or
 - 2. a stairway complying with this Code, except if the *exit* is from a Class 9a *building*.
- (d) The discharge point of alternative *exits* must be located as far apart as practicable.
- (e) In a Class 9b *building* which is an *open spectator stand* that accommodates more than 500 persons, a *required stairway* or *required ramp* must not discharge to the ground in front of the stand.
- (f) In a Class 9b *building* containing an auditorium which accommodates more than 500 persons, not more than 2/3 of the *required width of exits* must be located in the main entrance foyer.

ND1.11 Horizontal Exits

Horizontal exits must:

- (a) not be counted as a *required exit*, when:
 - 1. between sole-occupancy units; or
 - 2. in a Class 9b *building* used as an *early childhood center*, primary or secondary *school*;

SECTION ND – ACCESS AND EGRESS

- (b) not comprise more than 50% of the number of *required exits* from any part of a *storey* which has been divided by a *fire wall*; and
- (c) have a clear area on each side of the *fire wall* to accommodate the total number of persons (calculated under ND1.13) from both parts of the *storey*, of not less than:
 - 1. 2.5 m² per patient in a Class 9a *building*; and
 - 2. 0.5 m² per person in any other case.

NDI.12 Non-required Stairways or Ramps

Non-required non-fire-isolated stairways or pedestrian ramps:

- (a) must not be used in a *ward area* in a Class 9a *building*;
- (b) may connect any number of *storeys* if they are:
 - 1. in an *open spectator stand* or indoor sports stadium
 - 2. in a carpark or an *atrium*; or
- (c) outside a *building*;
- (d) must not connect, directly or indirectly, more than two consecutive *storeys* at any level in a Class 5, 6, 7, 8, or 9 *building*; and
- (e) in any other case, must not connect more than two consecutive *storeys*, provided that one of those *storeys* is situated at a level at which there is direct egress to a road or *open space*.

ND1.13 Number of Persons Accommodated

The number of persons accommodated in a *storey*, room or *mezzanine floor* must be determined with consideration to the purpose for which it is used and the layout of the *floor area* by:

- (a) calculating the sum of the numbers obtained by dividing the *floor area* of each part of the *storey* by the number of square meters per person listed in Table ND1.13 according to the use of the part, excluding spaces set aside for:
 - 1. stairs, ramps, corridors, hallways, lobbies, and the like;
 - 2. service ducts and the like, *sanitary compartments* or other ancillary uses;
- (b) reference to the seating capacity in an *assembly building* or room; or
- (c) any other suitable means of assessing its capacity.

Table ND1.13: Area Per Person According to Use

Type of use		m ² per person
Art gallery, exhibition area, museum		4
Bar, café, church, dining room		1
Board room		2
Boarding house		15
Computer room for main frame and computers		25
Court room	Judicial	10
	Public seating	1
Dance floor		0.5
Dormitory		8
Early childhood center		4

SECTION ND – ACCESS AND EGRESS

Type of use		m ² per person
Factory	(a) Machine shop, fitting shop, or like place for cutting, grading, finishing or fitting of metals or glass, except in the fabrication of structural steelwork or manufacture of vehicles or bulky products	5
	(b) Areas used for fabrication and processing other than those in (a)	50
	(c) A space in which the layout and natural use of fixed plant or equipment determine the number of persons which will occupy the space during working hours	Area per person determined by the use of the plant or equipment
Garage	Public	30
Gymnasium		3
Hospital <i>ward area</i>		10
Hostel, hotel, motel, guest house		15
Indoor sports stadium arena		10
Kiosk		1
Kitchen, laundry (other than domestic) and laboratory		10
Library:	Reading space	2
	Storage space	30
Office, including one for typewriting or document copying or with desktop computers		10
Plant room for:	Ventilation, electrical or other service units	30
	Boilers or power plant	50
Reading room		2
Restaurant		1
School	Common staff room	2
	Individual staff room	10
	General classroom	2
	Only as for others	
	Multi-purpose hall	1
	Trade and practical area:	
	Primary	4
	Secondary	As for workshop
Shop	Space for sale of goods	
	(a) At a level entered direct from the open air or any lower level	3
	(b) All other levels	5
Showroom	Display	5

Type of use		m ² per person
Skating rink, based on rink area		1.5
Spectator stand, audience viewing area:		
	Bench seating	450 mm/person
	Fixed seating	number of seats
	Seating not fixed	1
	Standing viewing area	0.3
Storage space		30
Swimming pool, based on pool area		1.5
Telephone exchange: private		30
Theatre dressing room		4
Transport terminal		2
Workshop	For maintenance staff	30 (in the whole area)
	For manufacturing processes	as for factory

ND1.14 Measurement of Distances

The nearest part of an *exit* means in the case of:

- (a) a *fire-isolated stairway, fire-isolated passageway, fire-isolated ramp*, the nearest part of the doorway providing access to them;
- (b) a *non-fire-isolated stairway*, the nearest part of the nearest riser;
- (c) a *non-fire-isolated ramp*, the nearest part of the junction of the floor of the ramp and the floor of the storey;
- (d) a doorway opening to a road or *open space*, the nearest part of that doorway;
- (e) a *horizontal exit*, the nearest part of the doorway.

ND1.15 Method of Measurement

The following rules apply:

- (a) In the case of a room that is not a *sole-occupancy unit* in a class 2 or 3 *building* or class 4 part of a *building*, the distance includes the straight-line measurement from any point on the floor of the room to the nearest part of a doorway leading from it, together with the distance from that part of the doorway to the single *required exit* or point from which travel in different directions to 2 *required exits* is available.
- (b) Subject to (d) and (f), the distance from the doorway of a room or *sole-occupancy unit* in a Class 2, 3, or 4 *building* is measured in a straight line to the nearest part of the *required single exit* or point from which travel in different direction to 2 *required exits* is available.
- (c) Subject to (d) and (f), the distance between *exits* is measured in a straight line between the nearest parts of those *exits*.
- (d) Only the shortest distance is taken along a corridor, hallway, external balcony or other path of travel that curves or changes direction.
- (e) If more than one corridor, hallway, or other similarly defined internal path of travel connects *required exits*, the measurement is along the path of travel through the point at which travel in different directions to those *exits* is available.

- (f) If a wall (including a demountable *internal wall*) that does not bound a room or a corridor, hallway, or the like causes a change of direction in proceeding to a *required exit*, the distance is measured along the path of travel past that wall.
- (g) If permanent fixed seating is provided, the distance is measured along the path of travel between the rows of seats.

ND 1.16 Emergency Exit Preparedness

In terms of emergency preparedness, *buildings* must include visual alarm systems, such as flashing lights, to alert individuals who are deaf or hard of hearing. For multi-storey *buildings*, it is essential to provide evacuation chairs or designate refuge areas to ensure safe evacuation for people with mobility impairments.

ND2 Construction of Exits

ND2.1 Application of Part

Except for ND2.13 and ND2.16, this Part does not apply to the internal parts of a *sole-occupancy unit* in a Class 2 or Class 3 *building* or a Class 4 part.

ND2.2 Fire-isolated Stairways and Ramps

A stairway or ramp (including any landings) that is *required* to be within a *fire-resisting shaft* must be constructed:

- (a) of *non-combustible* materials; and
- (b) so that, if there is local failure, it will not cause structural damage to, or impair the fire resistance of, the *shaft*.

ND2.3 Non-fire-isolated Stairways and Ramps

In a *building* having a rise of more than two *storeys*, *required* stairs and ramps (including landings and any supporting *structural members*) which are not *required* to be within a *fire-resisting shaft*, must be constructed according to ND2.2, or only of:

- (a) reinforced or prestressed concrete; or
- (b) steel in no part less than 6 mm thick; or
- (c) timber that:
 1. has a finished thickness of not less than 40 mm;
 2. has an average density of not less than 800 kg/m³ at a moisture content of 12%; and
 3. has not been joined by means of glue unless it has been laminated and glued with resorcinol formaldehyde or resorcinol phenol formaldehyde glue.

ND2.4 Separation of Rising and Descending Stair Flights

If a stairway serving as an *exit* is *required* to be fire-isolated:

- (a) there must be no direct connection between a flight of stairs rising from a *storey* below the lowest level of access to a road or *open space*; and a flight of stairs descending from a *storey* above that level; and
- (b) any construction that separates or is common to the rising and descending flights of stairs must be *non-combustible* and have an FRL of not less than 60/60/60.

ND2.5 Open Access Ramps and Balconies

A *required* open access ramp or balcony must:

- (a) have ventilation openings to the outside air which:
 - 1. have a total unobstructed area not less than the floor area of the ramp or balcony; and
 - 2. are evenly distributed along the open sides of the ramp or balcony; and
- (b) not be enclosed on its open sides above a height of 1 m except by an open grille or the like having a free air space of not less than 75% of its area.

ND2.6 Smoke lobbies

A smoke lobby *required* by ND1.7 must:

- (a) have a *floor area* not less than 6 m²;
- (b) be separated from the occupied areas in the *storey* by walls which are impervious to smoke, and:
 - 1. have an FRL of not less than 30/30/- (which may be plasterboard, face brickwork, glass blocks or glazing);
 - 2. extend from floor to floor, or to the underside of a ceiling with a *resistance to the incipient spread of fire* of 60 minutes which covers the lobby; and
 - 3. construction joints between the top of the walls and the floor, roof or ceiling must be smoke sealed with intumescent putty or other suitable material;
- (c) at any opening from the occupied areas, have smoke doors to Specification NC3.4, which are *self-closing* or held open by a fail-safe *automatic* magnetic release device; and
- (d) be pressurized to NE2.7 as part of the *exit* if the *exit* is *required* to be pressurized.

ND2.7 Installations in Exits and Paths of Travel

- (a) Access to service *shafts* and services other than to firefighting or detection equipment as permitted in Section NE, must not be provided from a *fire-isolated stairway, passageway, or ramp*.
- (b) An opening to any chute or duct conveying hot products of combustion must not be located in any part of a *required exit* or any corridor, hallway, lobby, or the like leading to a *required exit*.
- (c) Gas or other fuel services must not be installed in a *required exit*.
- (d) Services or equipment must not be installed in a *required exit* or in any corridor, hallway, lobby or the like leading to a *required exit* if it comprises:
 - 1. electricity meters, distribution boards, or duds;
 - 2. central telecommunications distribution boards or equipment; or
 - 3. electrical motors or other motors serving equipment in the *building*unless it is enclosed by *non-combustible* construction or a fire protective covering.

ND2.8 Enclosure of Space under Fire-isolated Stairs and Ramps

- (a) **Fire-isolated stairways and ramps:** If the space below a *required fire-isolated stairway or ramp* is within the fire-isolated *shaft*, it must not be enclosed to form a cupboard or similar enclosed space.
- (b) **Non-fire-isolated stairways and ramps:** The space below a *required non-fire-isolated stairway* (including an external stairway) or *ramp* must not be enclosed to form a cupboard or other enclosed space unless:
 - 1. the enclosing walls and ceilings have an FRL of not less than 60/60/60; and
 - 2. any access doorway to the enclosed space is fitted with a self-closing -/60/30 fire door.

ND2.9 Width of Stairways

- (a) The *required* width of a stairway must:
 - 1. be measured clear of all obstructions such as handrails, projecting parts of balustrades, columns, beams, and the like; and
 - 2. extend without interruption, except for ceiling cornices, to a height not less than 2 m vertically above a line along the nosings of the treads or the floor of the landing.

SECTION ND – ACCESS AND EGRESS

- (b) A *required* stairway that exceeds 2 m in width is counted as having a width of only 2 m unless it is divided by a balustrade or handrail continuous between landings and each division is less than 2 m wide.

ND2.10 Ramps

ND 2.10.1 Pedestrian ramps

- (a) A *fire-isolated ramp* may be substituted for a *fire-isolated stairway* if the construction enclosing the ramp and the width and ceiling height comply with the requirements for a *fire-isolated stairway*.
- (b) A ramp serving as a *required exit* must be designed as follows:

Slope: 1:20 is the recommended minimum for a non-assisted person in a wheelchair. The slope can be increased to 1:14 where the wheelchair user is assisted. Greater than 1:12 is considered a hazard.

Width: Varies according to use, configuration and slope, but the minimum is 1 m.

Landings: Provide at least every 9 m, at every change of direction and at the top and bottom of every ramp. Landing width should be a minimum 1 m and clear from obstructions.

Handrails: Provide on both sides and along the full length of every ramp, 900 mm to 1 m high, returning at ends or turning down to minimize injuries. Handrails should extend for a distance of minimum 300 mm at the top and bottom of ramps. For ramps wider than 3 m, an intermediate rail could be installed.

The **floor surface** of a ramp must have a non-slip finish.

ND2.10.2 Service ramps

Service ramps must not be steeper than 1:3. Where they are steeper than 1:8 cleats must be provided at the spacing shown in Table ND2.10.2. Two examples are shown in Figure ND2.10.2.

Table ND2.10.2: Spacing of Cleats for Service Ramps

Ramp slope not more than	Cleat spacing (mm)	
	Goods carried	No goods carried
1:6	360	460
1:5	330	430
1:4	300	400
1:3	280	380

Figure ND2.10.2: Examples of Service Ramps with Cleats

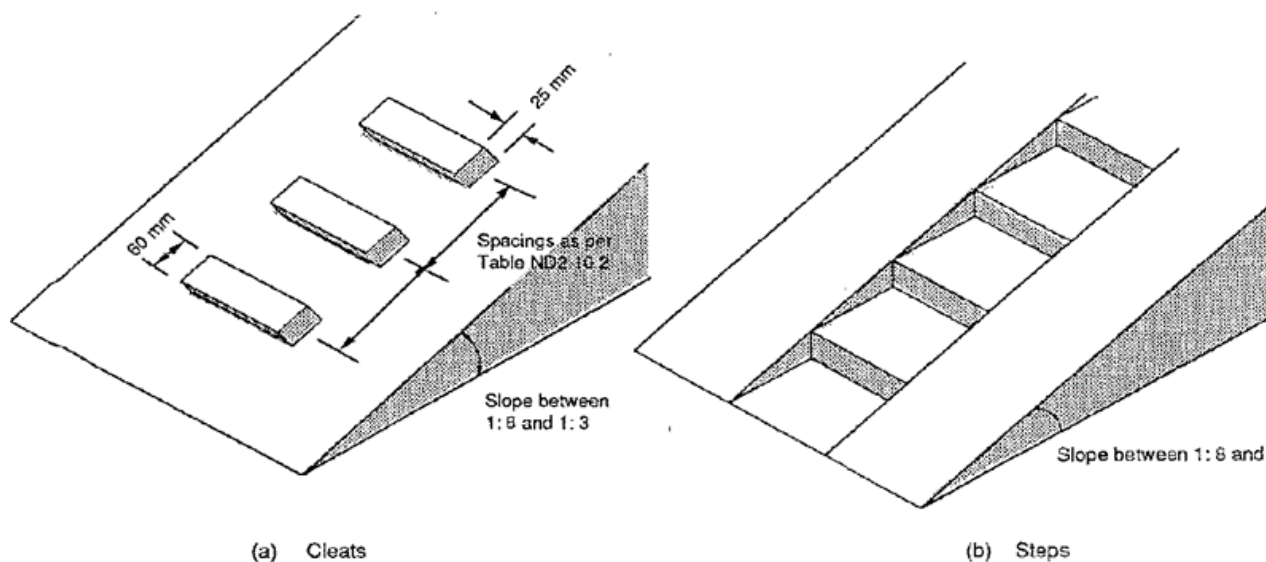

ND2.11 Fire-isolated Passageways

A *fire-isolated passageway* must be enclosed by walls, floors, and ceilings of *non-combustibles* construction with an FRL of:

- not less than that *required* for the stairway or ramp *shaft* if the passageway discharges from a *fire-isolated stairway* or ramp; or
- in any other case: not less than 60/60/60.

ND2.12 Roof as Open Space

If an *exit* discharges to a roof of a *building*, the roof must:

- have an FRL of not less than 120/120/120; and
- not have any roof lights or other openings within 3 m of the path of travel of persons using the *exit* to reach a road or *open space*.

ND2.13 Treads and Risers

ND2.13.1 Straight Flights

- A stairway must be suitable to provide safe passage in relation to the nature, volume and frequency of likely usage.
- A stairway in any *building* (including a *sole-occupancy unit* in a Class 2 or 3 *building* or Class 4 part) satisfies (a) if it has:
 - not more than 18 nor less than 2 risers in each flight, except in a Class 9 *building* subject to ND1.7(d);
 - subject to the last dot point on sole occupancy units below, going and riser dimensions in accordance with Figure ND2.13.1 and Table ND2.13.1 that are constant throughout each flight;
 - risers which do not have any openings that would allow a 100 mm sphere to pass through between the treads;
 - treads which have a non-slip finish or a suitable non-skid strip near the edge of the nosings;
 - treads of solid construction (not mesh mother perforated material) if the stairway is more than 10 m high or connects more than three *storeys*;
 - in a Class 9 *building*: not more than 36 successive risers and landings without a change in direction of at least 30°;
 - across fall of between 1:100 and 1:50 where the stairway is subject to wetting;
 - treads do not exceed the goings by more than 30 mm; and
 - in a sole occupancy unit in a class 2 *building* or class 4 part, or where it is not part of a *required exit* and to which there is no normal access to the public, going and riser dimensions to Table DD1.1.

Figure ND2.13.1: Measurement of Riser Going and Tread

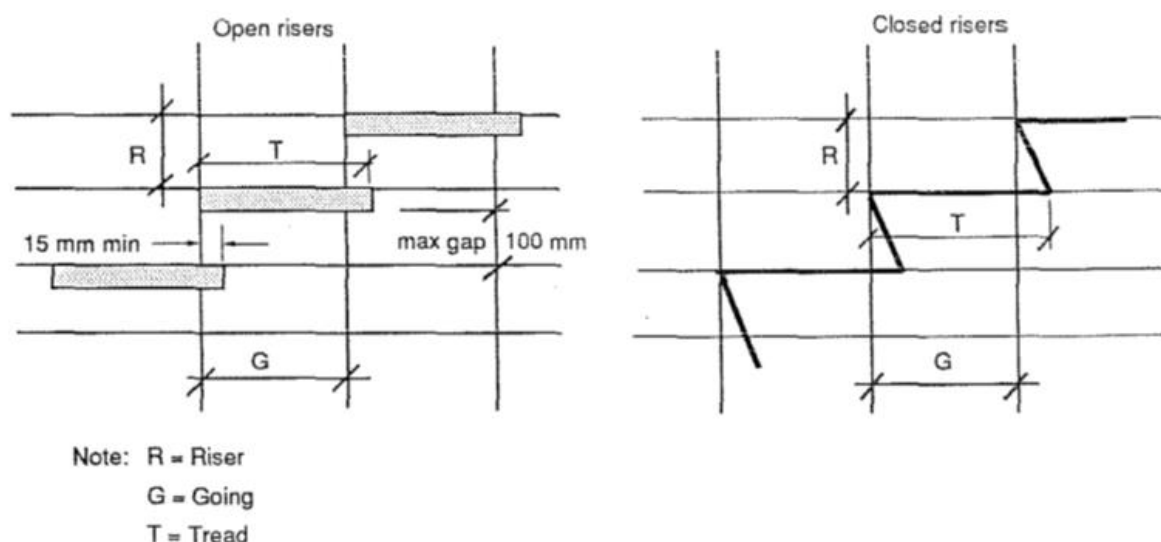

Table ND2.13.1: Riser Dimensions (mm) to Match Going

Pitch	GOING (mm)								
	250	260	270	280	290	300	310	320	330
37°	188								
36°	182	188							
35°	175	182	189						
34°	168	175	182	188					
33°	162	169	175	181	188				
32°	156	162	168	174	181	187			
31°	150	156	162	167	174	180	186		
30°		150	156	161	167	173	179	185	
29°			150	155	161	167	173	179	183
28°				150	155	160	165	170	175
27°					148	153	158	163	168
26°						146	151	156	161
25°								149	154
24°									147

Notes:

(a) Actual riser dimension may be selected to suit the inter-landing height. However, the value of the riser dimension must not be outside the maximum or minimum dimensions shown for each value of going.

(b) The dimensions shown within the outlined box are preferred because they are less strenuous for individuals on crutches or with minor disabilities.

ND2.13.2 Curved Stairs

Curved stairs must comply with the relevant requirements of ND2.13.1 as well as the following:

- (a) For the purposes of satisfying Table ND2.13.1 or Table DD1.1 in the case of stairs in ND2.13.1 (ix), the going must be measured:
 1. along halfway across the width of the stair where the clear width is less than 900 mm; and
 2. 300 mm from each side of the stair where the clear width is 900 mm or more.
- (b) All steps must have the same uniform taper.
- (c) The going at the narrow end of the steps must be not less than 75 mm.
- (d) Winders are not permitted.

ND2.14 Landings

In a stairway:

- (a) landings having a maximum slope of 1:50 may be used in any *building* to limit the number of risers in each flight and each landing must:
 1. be not less than 750 mm long measured 500 mm from the inside edge of the landing; and
 2. have a non-slip finish throughout or a suitable non-skid strip near the edge of the landing where it leads to a flight of stairs below; and

in a Class 9a *building*:

1. the area of any landing must be sufficient to move a stretcher, 2 m long and 600 mm wide, at an incline not more than the slope of the stairs, with at least one end of the stretcher on

- the landing while changing direction between flights; or
- 2. the stair must have a change of direction of 180°, and the landing a clear width of not less than 1.6 m and a clear length of not less than 2.7 m.

ND2.15 Thresholds

The threshold of a doorway must not incorporate a step or ramp at any point closer to the doorway than the width of the door leaf unless:

- (a) in patient-care areas in a Class 9a *building*, the door sill is not more than 25 mm above the finished surface of the ground, balcony or the like to which the doorway opens;
- (b) in other cases:
 - 1. the doorway opens to a road, *open space* or external balcony; and
 - 2. the door sill is not more than 190 mm above the finished surface of the ground, balcony, or the like, to which the doorway opens.

ND2.16 Balustrades

- (a) In a Class 2, 3, 4, 5, 6, or 9 *building* and a Class 7 *building* used as a *public carpark*, a continuous balustrade must be provided along the side of any stairway or ramp, or any corridor, hallway, balcony, bridge or the like, if:
 - 1. it is not bounded by a wall; and
 - 2. the change in level is more than 1 m,except at the perimeter of a *stage*, rigging loft, loading dock, an area accessible only to maintenance staff, or the like.
- (b) A balustrade *required* by (a) must prevent, as far as practicable:
 - 1. children climbing over or through it
 - 2. persons accidentally falling from the floor; and
 - 3. objects which might strike a person at a lower level accidentally falling from the floor surface.
- (c) In low-risk areas such as *fire-isolated stairways*, *fire-isolated ramps* or external stairways that are provided instead of *fire-isolated stairways*, other areas used exclusively for emergency purposes and other stairways and ramps (including access bridges and landings), where the change in level is not more than 2 m, a balustrade satisfies (b) if:
 - 1. the balustrade has a height of not less than 865 mm above the nosings of the stair treads and the floor of the landing, access bridge or the like; and
 - 2. the space between *balusters* or the width of any opening in the balustrade (including any openable *window* or panel) is not more than 100 mm except where the space between rails or the height of any opening is not more than 100 mm.
- (d) At balconies a balustrade satisfies (b) if:
 - 1. it has a height of not less than 930 mm above the balcony floor;
 - 2. the space between *balusters* or the width of any opening in the balustrade is not more than 100 mm except where the space between rails or the height of the opening is not more than 100 mm;
 - 3. all parts of the balustrade more than 150 mm and less than 760 mm from the floor or nosings are vertical or otherwise do not provide a toehold; and
- (e) In stairways and ramps (including access bridges and landings) where the change in level is more than 2 m, a balustrade satisfies (b) if:
 - 1. it has a height of not less than 865 mm above the nosings of the stair treads and the floor of the landing, balcony, corridor, hallway, access bridge or the like
 - 2. the space between *balusters* or the width of any opening in the balustrade (including any openable *window* or panel) is not more than 100 mm except where the space between rails or the height of the opening is not more than 100 mm; and
 - 3. all parts of the balustrade more than 150 mm and less than 760 mm from the floor or nosings are vertical or otherwise do not provide a toehold.
- (f) A balustrade or other barrier in front of fixed seating in a *mezzanine floor* or balcony in a Class 9b *building* satisfies (b) if it complies with (d), or:

1. it is not less than 700 mm in height above the *mezzanine floor* or balcony floor and a horizontal projection extends not less than 1 m outwards from the top of the balustrade; and
2. the space between *balusters* or the width of any opening in the balustrade is not more than 100 mm except where the space between rails or the height of the opening is not more than 100 mm.

ND2.17 Handrails

- (a) Except in a Class 7 or 8 *building* other than a *public carpark*, suitable handrails must be provided where necessary to assist and provide stability to persons using a ramp or stairway, including people with disabilities, children, little people, pregnant women, and older adults.
- (b) Handrails satisfy (a) if they are:
 1. located along at least one side of the ramp or flight of stairs;
 2. located along each side if it is a Class 9b *building* that is used as an *early childhood center* or as a *primary school*, or if the total width of the stairway or ramp is 2 m or more;
 3. not more than 2 m apart in the case of intermediate handrails; fixed at a height of not less than 700 mm above the nosings of stair treads in a Class 9b *building* that is used as a *primary school*;
 4. in any other case fixed at a height of not less than 865 mm above the nosings of stair treads and the floor surface of the ramp, landing, or the like; and
 5. continuous between stair flight landings and have no obstruction on or above them that will tend to break a handhold.
- (c) Handrails in a Class 9a *building* must be provided along at least one side of every passageway or corridor used by patients, and must be:
 1. fixed not less than 50 mm clear of the wall; and
 2. where practicable, continuous for their full length.
- (d) Where handrails are located on an *accessible route* they should be installed at 760 mm and 900 mm height, with slip-resistant, continuous gripping surfaces and must be provided on both sides of all stairs and ramps and should extend across landings. To ensure safety, comfort, and usability, all handrails on an *accessible route* must meet the following criteria:
 1. be slip-resistant and have rounded ends to prevent injury;
 2. have a circular cross-section with a diameter between 38 mm and 45 mm for a comfortable grip;
 3. be free from sharp edges or abrasive surfaces;
 4. provide a continuous gripping surface without breaks or obstructions that interrupt handhold;
 5. be visually distinguishable from adjacent walls or floors through the use of contrasting colours.

ND2.18 Fixed Platforms, Walkways, and Ladders

Fixed platforms, walkways, non-*required* stairways, handrails, balustrades and ladders must comply with AS 1657 in:

1. a Class 7 or Class 8 *building*, or part of a *building*; and
2. lift motor rooms, plant rooms, and the like.

ND2.19 Doorways and Doors

A doorway serving as a *required exit*, forming part of a *required exit*, or in a patient-care area of a Class 9a *building*:

- (a) must not be fitted with a revolving door;
- (b) must not be fitted with a roller shutter or tilt-up door unless:
 1. it serves a Class 6, 7, or 8 *building* or part with a *floor area* not more than 200 m²;
 2. the doorway is the only *required exit* from the *building* or part; and
 3. it is held in the open position while the *building* or part is lawfully occupied;

SECTION ND – ACCESS AND EGRESS

- (c) must not be fitted with a sliding door unless:
 - 1. it leads directly to a road or *open space*; and
 - 2. the door can be opened manually under a force of not more than 10 kg; and
- (d) if fitted with a door which is power-operated:
 - 1. it must be able to be opened by hand under a force of not more than 10 kg if there is a malfunction or failure of the power source; or
 - 2. it must open *automatically* if there is a power failure or on the activation of a fire or smoke alarm anywhere in the part served by the door; and
- (c) comply with *universal design* standards, which require:
 - 1. a minimum clear width of 0.9 m to allow easy access for wheelchair users and people using mobility aids;
 - 2. avoiding pinching, gripping, or twisting when operating, doors should be easy to open with minimal effort;
 - 3. lever-style handles, placed at a height of 0.8 m from the floor, are preferred over round knobs because they are easier to use for people with limited hand strength or dexterity, such as those with arthritis or cerebral palsy;
 - 4. if thresholds are present, they should not be higher than 12 mm to help prevent tripping and allow smooth movement for wheelchair users, people with walking frames, and those with vision impairments; and
 - 5. glass doors to have clear visual markers or patterns added to make them visible and prevent accidents—especially for people with low vision or cognitive disabilities.

ND2.20 Swinging doors

A swinging door in a *required exit* or forming part of a *required exit*:

- (a) must not encroach:
 - 1. at any part of its swing by more than 500 mm on the *required* width of a *required* stairway, passageway or ramp, including the landings; and
 - 2. when fully open, by more than 100 mm on the *required* width of the *required exit*, andthe measurement of encroachment in each case is to include door handles or other furniture or attachments to the door;
- (b) must swing in the direction of egress unless:
 - 1. it serves a *building* or part with a *floor area* not more than 200 m², it is the only *required exit* from the *building* or part and it is fitted with advice for holding it in the open position; or
 - 2. it serves a *sanitary compartment* or airlock (in which case it may swing in either direction); and;
- (c) must not otherwise impede the path or direction of egress.

ND2.21 Operation of Latch

A door in a *required exit*, forming part of a *required exit* or in the path of travel to a *required exit*, must be readily openable without a key from the side that faces a person seeking egress, by a single-hand downward or horizontal pushing action on a single device which is located between 900 mm and 1,200 mm from the floor, unless:

- (a) it serves a vault, strong room, *sanitary compartment*, or the like; or
- (b) it serves only, or is within:
 - 1. a *sole-occupancy unit* in a Class 2 *building* or a Class 4 part;
 - 2. a *sole-occupancy unit* in a Class 5, 6, 7 or 8 *building* with a *floor area* not more than 200 m²; or
 - 3. a space which is otherwise inaccessible to persons at all times when the door is locked; or
- (c) it serves a bank or other occupancy where special arrangements for security are necessary and it can be immediately unlocked:
 - 1. by operating a fail-safe control switch, not contained within a protective enclosure, to actuate a device to unlock the door; or
 - 2. by hand by a person or persons, specifically nominated by the owner, properly instructed as to the duties and responsibilities involved and available at all times when the *building* is

lawfully occupied so that persons in the *building* or part may immediately escape if there is a fire or other emergency; or

- (d) it is fitted with a fail-safe device which *automatically* unlocks the door upon the activation of any *sprinkler system* or smoke or thermal detector system installed throughout the *building*.

ND2.22 Re-entry from Fire-isolated Exits

Doors must not be locked from inside a *fire-isolated stairway*, *fire-isolated ramp* or *fire-isolated passageway* enclosure to prevent re-entry to the *storey* or room it serves in:

- (a) a Class 9a *building*; or
- (b) a *building* more than 25 m in *effective height* unless all the doors are *automatically* unlocked by a fail-safe device upon the activation of a fire alarm, and at least at every fourth *storey* the doors are not able to be locked and a sign is fixed on it stating that re-entry is available.

ND3 Access for People with Disabilities

ND3.1 Application of Part

This Part applies to all Class 3, 5, 6, 7, 8, and 9 *buildings*. For Class 1, 2, 4, and 10 *buildings* refer DD 2.1.

ND3.2 Access to Buildings

Access for people with disabilities must be provided to all *buildings* as set out in Table ND 3.2 by means of a continuous path of travel and as described in the Australian Department of Foreign Affairs (DFAT): Accessibility Design Guide: Universal Design principles for Australia’s Aid Program: Annex A: Built Environment: (Available free of charge DFAT website):

- (a) from the boundary of the allotment;
- (b) from any carpark space on the allotment (whether within or outside the *building*):
 1. that is set aside for people with disabilities using the *building*; or
 2. if there are no carpark spaces set aside for people with disabilities, from any carpark area that serves the *building*; and
- (c) from any other *building* on the allotment to which access for people with disabilities is *required*.

Table ND3.2: Requirements for Access for People with Disabilities

Class of building	Access requirements
Class 3 (a) If the <i>building</i> contains: more than 10 units up to 49 units more than 49 but not more than 99 more than 99 units. (b) If accommodation is provided for more than 10 persons other than in <i>sole-occupancy units</i> : up to 49 beds more than 49 but not more than 99 more than 99. (c) Common areas of <i>buildings</i> that are <i>required</i> to be accessible.	To and within: 1 sole-occupancy unit. 2 sole-occupancy units. 3 sole-occupancy units. To and within: 2 beds. 4 beds. 6 beds. The entrance floor and to all public areas on that floor.

SECTION ND – ACCESS AND EGRESS

Class of building	Access requirements
Class 5 and 6	To and within the entrance floor if its <i>floor area</i> is more than 500 m ² .
Class 7	To and within the entrance floor if the total <i>floor area</i> of the <i>building</i> is more than 3,000 m ² .
Class 8	To and within the entrance floor if the total <i>floor area</i> of the <i>building</i> is more than 3,000 m ² .
Class 5, 6, 7, and 8	To and within any floor if irrespective of <i>floor area</i> , the floor is not more than 190 mm at the point of entrance above or below the adjacent finished ground level; and within any other floor to which vertical access by way of a ramp, step or kerb ramp, or passenger lift is provided.
Class 9a	To and within all areas normally accessible to the public, patients or staff.
Class 9b- An <i>assembly building</i> not being a school or an early childhood center.	To and within every room that accommodates more than 100 persons, and if fixed seating is provided, not less than 1 wheelchair space for each 200 seats, or part, with a minimum of 2 spaces; and within any other floor to which vertical access by way of a ramp, step or kerb ramp, or passenger lift is provided. To and within every room used by children.
Notes: <ol style="list-style-type: none">1. The calculation of <i>floor area</i> and the number of persons accommodated are in accordance with ND1.13.2. For the purposes of this Table, a double/queen/king bed counts as 1 bed.3. A kerb ramp is a plastic or rubber ramp with a maximum 1:10 slope that is designed to provide easy access over or up a kerb for wheelchairs, pedestrians, or vehicles.	

ND3.3 Parts of buildings to be accessible

- (a) Access for people with disabilities, in particular those with a physical or visual impairment, must be provided:
1. from the doorway at the entrance floor providing access to any *sanitary compartment required* for the use of people with disabilities; and
 2. to areas normally used by the occupants, including emergency exits but excluding any plantroom, commercial kitchen, cleaners' storeroom, maintenance *accessway*, rigging loft, or the like.
- (b) A path of travel providing *required* access must not include a stairway, turnstile, revolving door, escalator or other impediment which would prevent a person in a wheelchair using it.
- (c) Access, finishes and fittings, including passageways, ramps, step or kerb ramps, passenger lifts, signs, doorways and other parts of the *building required* by this Part must comply at least with the provisions set out in the Australian Department of Foreign Affairs (DFAT): Accessibility Design Guide: Universal Design principles for Australia's Aid Program: (Available free of charge DFAT website).

ND3.4 Common Building Elements

Common *building elements* for accessibility include:

- (a) Controls and operating mechanism: e.g. vending machines, electrical switches, wall sockets, etc.;

SECTION ND – ACCESS AND EGRESS

- (b) Colour contrast: persons with vision impairment need colours to contrast sharply against background for them to successfully identify the objects, walls, and obstacles;
- (c) Flooring: non-slip;
- (d) Lighting: good lighting and contrasting environmental features to highlight them against their background;
- (e) Tactile pathway: tactile guiding blocks (line type) indicate correct path/route to follow and tactile warning blocks (dot-type) to indicate an approaching hazard or change in direction;
- (f) Signage: Signage is a critical component of the built environment, serving as a primary means of communication and navigation for all users. Well-designed signage not only enhances the overall user experience but also ensures that people with disabilities—such as those with visual, hearing, cognitive, or mobility impairments—can navigate spaces independently and safely. Effective signage reduces the cognitive and physical effort required for wayfinding and supports inclusive access to services and facilities. To meet diverse user needs, signage should include the following categories:
 - Directional: Guides users to specific destinations.
 - Informational: Provides general or contextual information.
 - Identification: Labels rooms, areas, or features.
 - Instructive: Offers operational or behavioural instructions.
 - Health and Safety: Communicates emergency exits, hazards, and safety protocols.
- (g) Design recommendations for inclusive signage: To ensure signage is universally *accessible*, the following features must be incorporated:
 1. Use contrasting colours between text/symbols and background to enhance visibility for users with low vision.
 2. Use legible fonts, appropriate spacing, and intuitive formatting to support readability and comprehension.
 3. Place signs at consistent and visible heights (typically 1.4–1.6 m from the floor) and in unobstructed locations.
 4. Ensure signs are readable from a reasonable distance based on their purpose and location.
 5. Maintain sufficient illumination to ensure visibility in all lighting conditions.
 6. Use matte finishes to prevent glare and ensure longevity, especially in outdoor or high-traffic areas.
 7. Where possible and practicable include tactile elements such as embossed letters, Braille, and pictograms to support users with visual impairments.

Evacuation signage must be readable, placed at accessible heights, and free from obstructions.

ND 3.5 Evacuation Plans

Ensure evacuation plans and emergency exit plans include provisions for persons with disabilities, ensuring that evacuation procedures identify *accessible routes* which include *accessible* exits and ramps that are inclusive, clearly communicated, and practically implementable for all users

The evacuation plans must be easily visible and *accessible* and displayed in all rooms and all floors of multi-storey buildings.

ND 3.6 Accessible Car Parking

Provide at least one *accessible* parking bay (minimum 3.6 m x 5.4 m) within 50 m of *accessible* entrance(s) that is visible and has accessibility signage.

Where possible and practicable, the parking area should be covered and covered walkways should be provided to ensure safe and *accessible* movement between carparks and *building* entrances for all users, especially persons with disabilities. People with disabilities, particularly those with mobility or health conditions, face increased risk when exposed to harsh weather while entering or exiting vehicles.

Section

NE



SERVICES & EQUIPMENT

THIS SECTION APPLIES TO PUBLIC
BUILDINGS AND GROUP DWELLINGS
(CLASS 2 to CLASS 9)

SECTION NE – SERVICES AND EQUIPMENT

Contents

PERFORMANCE REQUIREMENTS	1
OBJECTIVES	1
NEP1 Fire Fighting Equipment	1
NEP2 Smoke Control	1
NEP3 Lift Installations	1
NEP4 Emergency Lighting, Exit Signs & Alarms.....	1
NEP5 Maintenance of Safety Installations	1
NEP6 Electrical Work.....	1
REQUIRED PERFORMANCE	2
NEP1.1 Active Fire Fighting	2
NEP2.1 Smoke Control	2
NEP3.1 Lift Installations.....	2
NEP4.1 Emergency Lighting	2
NEP4.2 Fire and Smoke Alarms	2
NEP4.3 Electrical Safety	3
NEP4.4 Electrical Amenity	3
NEP4.5 Energy Efficiency	3
DEEMED-TO-SATISFY PROVISIONS	4
NE1 Fire Fighting Equipment.....	4
NE1.1 Application of Part.....	4
NE1.2 Fire mains and Water Supply.....	4
NE1.3 Riser main system	4
NE1.4 Where Hydrants are Required	4
NE1.5 Hose Reels.....	5
NE1.6 Portable Fire Extinguishers	5
NE1.7 Fire and smoke alarms.....	5
NE1.8 Fire precautions during construction.....	6
NE1.10 Provision for special hazards.....	7
NE2 Smoke Control	7
NE2.1 Smoke Venting	7
NE2.2 Exclusion of smoke from fire-isolated exits.....	7

SECTION NE – SERVICES AND EQUIPMENT

NE2.3 Natural smoke venting.....	8
NE2.4 Air-handling systems	8
NE2.5 Roof vents	8
NE3 Lift Installations	8
NE3.1 Application of Part.....	8
NE3.3 Warning Against Use of Lifts in Fire or Earthquake.....	8
NE3.4 Emergency Lifts.....	9
NE 4 Emergency Lighting, Exit Signs & Warning System	9
NE4.1 Application of Part.....	9
NE4.2 Emergency Lighting Requirements	9
NE4.3 Measurement of Distance.....	10
NE4.4 Design and Operation of Emergency Lighting	10
NE4.5 Exit Signs.....	10
NE4.6 Direction Signs	10
NE4.7 Class 2, 3 and 4 buildings: Exemptions.....	10
NE4.8 Design and Operation of Exit Signs	11
NE 5 Inspection, Test & Maintenance of Safety Installations	11
NE5.1 Application of Part.....	11
NE5.2 Maintenance Requirements.....	11
NE6 Electrical Work	13
NE6.1 Electrical Safety	13
NE6.2 Amenity.....	13

SPECIFICATIONS

SPECIFICATION NE1.2:	Fire Mains and Water Supply Services
SPECIFICATION NE1.7:	Fire Detection and Alarm Systems
SPECIFICATION NE1.11:	Occupancies of Excessive Fire Hazard
SPECIFICATION NE2.4:	Air Handling Systems in Buildings
SPECIFICATION NE2.6:	Smoke Exhaust Systems

PERFORMANCE REQUIREMENTS

OBJECTIVES

A *building* must be so designed and constructed that the following objectives are fulfilled:

NEP1 Firefighting Equipment

Having regard to the size and use of the *building* and its Type of construction, adequate in-built and external fire protection services must be provided to:

- (a) restrict the growth to the compartment of origin;
- (b) prevent fire spread to adjoining *buildings* or allotments; and
- (c) facilitate the fighting of fire to minimize damage to the *building* and its contents.

NEP2 Smoke Control

Air-handling systems installed in a *building* must:

- (a) provide suitable air for the health and safety of the occupants; and
- (b) incorporate reasonable measures to minimize the spread of smoke in the event of fire to escape paths from the *building* to other compartments and to enable access by fire fighters.

NEP3 Lift Installations

Lifts where provided must have regard to the nature of any emergency:

- (a) to assist in the evacuation of the occupants; and
- (b) to facilitate access by fire-fighting and other emergency personnel.

NEP4 Emergency Lighting, Exit Signs & Alarms

- (a) Emergency lighting and *exit* signs must be provided where necessary to facilitate safe egress in an emergency upon failure of the normal lighting.
- (b) Suitable alarm systems must be provided to alert occupants of an emergency, initiate *automatic* counter measures and summon emergency personnel.

NEP5 Maintenance of Safety Installations

Equipment, installations and components critical to the safety of the *building* or the occupants must be adequately maintained in such condition that will enable their proper performance.

NEP6 Electrical Work

All electrical work must meet the following objectives:

- (a) it must prevent electrocution, burns, or fire; and
- (b) it must satisfy the reasonable expectations of the users by ensuring that it is adequate for their intended use, both current and anticipated.

REQUIRED PERFORMANCE

NEP1.1 Active Firefighting

In determining the type and extent of active firefighting systems that must be provided for a *building*, the following must be taken into account:

- (a) the class of occupancy;
- (b) proximity to fire-source features;
- (c) Type of construction in relation to fire resistance;
- (d) size of fire compartments;
- (e) effective height;
- (f) the flow rate and pressure of available water supply;
- (g) the capacity of the Fire Brigade or other firefighting organization that serves the area where the *building* is located; and
- (h) the technical resources available locally to satisfactorily install and regularly test and maintain the active firefighting system.

NEP2.1 Smoke Control

Air-handling systems in *buildings* must be no more complex than what is given in the *Deemed-to-Satisfy Provisions* unless satisfactory evidence is produced to show that the level of expertise available on an on-going basis would be adequate to keep them regularly tested serviced and maintained in a sound condition. Air-handling systems must be such that smoke is not transported from the compartment or locality of origin to escape paths and other *fire compartments or storeys* to a concentration that might affect the safety of the occupants or hinder the work of fire fighters.

NEP3.1 Lift Installations

Lift installations in tall *buildings* must be capable of transporting stretches without discomfort. Effective warning must be displayed against the use of lifts during fires or earthquakes. In very tall *buildings* at least one lift must be such that it can be safely operated during emergencies such as fire and be switched during the emergency for operation by only emergency personnel such as fire fighters.

NEP4.1 Emergency Lighting

In three-storey or higher residential *buildings*, in other than small *buildings* where the occupants are transient, and in all other *buildings* emergency lighting must be provided to clearly indicate, *exits* and the doors guarding such *exits* must be identifiably marked. Such *buildings* must also have emergency lighting available to facilitate the occupants to reach the *exits* without confusion and to safely negotiate the *exits* until they can be in a road or *open space*. The route to the *exits* must be identifiably marked. In hospitals and in areas where emergency personnel operate, there must be adequate emergency lighting to avoid patient trauma or hardship and to permit the staff to carry out emergency functions.

All emergency lighting must automatically operate in the event of any failure of normal lighting for a period long enough for the evacuation of all the occupants, plus a margin. Such lighting must give an adequate level of illumination to allow evacuation without hindrance.

NEP4.2 Fire and Smoke Alarms

Reliable detection and warning systems must be installed for *automatic* operation in the event of a fire or generation of unacceptable levels of smoke. In the case of:

- (a) all *buildings* of 4 stories and above;
- (b) *buildings* of medium size or larger, frequented by the public and where flammable and consumer goods are displayed; and

- (c) occupancies of excessive hazard of moderate size or larger, the detection systems on initiation must *automatically* activate suitable firefighting systems and *automatically* notify the fire services.

NEP4.3 Electrical Safety

The supply system must:

- (a) have suitable devices of adequate interruptive duty to automatically shut off the supply in the event of a fault-or overload (such devices must allow easy reinstatement of the supply after interruption);
- (b) have devices which are clearly identified and easily reached to isolate live parts from the incoming supply;
- (c) be constructed and installed to ensure that no part of the system can be subjected to a voltage higher than that for which the system was designed;
- (d) when the neutral of the supply is earthed, have socket outlet or plug: socket adaptor construction, which would ensure that the live, neutral, and earth conductors can only be connected to the corresponding live, neutral and earth conductors of the plug;
- (e) where it is a common simple system, be so compatible that the safety features of the system itself are not impaired;
- (f) where it has a multiple earthed neutral system, have an adequate connection between the neutral conductor and earth at each consumer's premises;
- (g) be adequately protected against damage arising from exposure to weather, water, or excessive dampness mechanical loads and other such agents expected under normal conditions of use; and
- (h) ensure that the main switch is normally accessible only to the occupants.

NEP4.4 Electrical Amenity

The supply system must have an adequate capacity to serve the reasonable anticipated needs of the users.

NEP4.5 Energy Efficiency

All *buildings*, including the operation and use of fixed appliances and building services (lighting, heating, domestic hot water, ventilation and air conditioning systems), must be designed and constructed to provide opportunities to reduce solar heat gain and promote cooling of the interior appropriate to:

- (a) the function and use of the *building*, facility and/or site;
- (b) the promotion of human comfort, health and safety in the interior environment;
- (c) the safe operation of storage, handling and fabrication of products and/or hazardous substances;
- (d) the geographic location, topography, hydrology and natural features;
- (e) *buildings*, facilities, site works and site servicing on adjacent property; and

Key Energy Efficiency aspects should align with the Vanuatu National Policy (NEESAP), the URA Regulation and Vanuatu Electricity Supplies Act and the SIEAPI Guidelines on Energy Efficiency.

DEEMED-TO-SATISFY PROVISIONS

NE1 Firefighting Equipment

NE1.1 Application of Part

This Part applies to Class 2, 3, 4, 5, 6, 7, 8, and 9 *buildings*.

NE1.2 Fire Mains and Water Supply

- (a) Where a permanently charged *fire main* and water supply system are available, these must provide a continuous supply of water at sufficient pressures and rates of flow to enable effective firefighting on any adjoining *building*. The system must in addition have *hydrants* located free of obstructions at appropriate intervals. The location of the *hydrants* must be suitably marked for ease of identification by the fire service.
- (b) In the case of *buildings* with a *rise* of 4 *storeys* or more where an adjoining permanently charged *fire main* and water supply system is not available, adequate on-*site* water storage and suitable fire pumps must be provided to give the rates and pressures of flow for firefighting, as per NZS4510.
- (c) A *fire main* and water supply system must comply with Specification NE1.2.

NE1.3 Riser Main System

Riser mains to NZS4510 must be provided in *buildings* with a *rise* of 5 *storeys* or more. In *buildings* with a *rise* of up to 8 *storeys*, a *charged dry riser main system* is allowable; for taller *buildings*, a *wet riser main system* is *required*. Any *wet riser main system* must be connected to a permanently charged *fire main*. In *buildings* with a *rise* of more than 8 *storeys*, a dedicated *automatic* starting fire pump or pumps in accordance with NZS4510 must be installed in the system to boost the pressure and/or the rates of flow to the values *required* by the Standard.

NE1.4 Where Hydrants Are Required

(a) General

One or more *hydrants* must be provided:

1. in each *storey* with a *floor area* of more than 750 m²;
2. in every *storey* if the *building* contains 5 *storeys* or more; and
3. on the roof if the *building* has a *rise* of more than 8 *storeys* except on:
 - i) a roof having a pitch of more than 10°; or
 - ii) a roof of a plant room or other subsidiary structure on the main roof.

(b) External hydrants

The configuration and location of a *building* and of adjacent external *hydrants* must be such that the farthest point on the *storeys* to which direct access from a street is available for the fire service, must be within reach of a 6 m spray from the nozzle of a 120 m fire hose.

External *hydrants* must be located:

1. not closer than 6 m from a *building* unless protected from it with a wall having an FRL of not less than 60/60/30 extending at least 2 m each side and 3 m above the *hydrant* outlets; and
2. not more than 20 m unobstructed distance from hard-standing access for a fire-pump appliance.

(c) Internal hydrants

1. The *riser main* system must provide for sufficient number and disposition of internal *hydrants* such that any point on any *storey* is within reach of a 6 m spray from the nozzle of a 45 m fire hose.
2. Internal *hydrants* must be located on the floor not more than 4 m from a *required exit*, or in a *required* stairway, passageway or ramp so as not to encroach on the required width of

the exit.

Hydrants for the ground floor of a *building* may be *external hydrants*.

NE1.5 Hose Reels

Hose reels must be installed in *buildings* as listed in Table NE1.5 and must:

- (a) not be located:
1. within a fire-isolated *exit*; or
 2. so that the hose will need to pass through the doorway fitted with a fire or smoke door; except a door to a *sole-occupancy unit* in a Class 2, 3, or 4 *building*;

Table NE1.5: Requirements for Firehose Reels

Occupancy	Fire hose reels required
Class 2	if more than 4 residential <i>storeys</i> contained
Class 3	if more than 2 residential <i>storeys</i> contained
Class 5, 6, 7, 8, or 9b	any <i>storey</i> if <i>floor area</i> of <i>storey</i> more than 750 m ²
Class 9a	all <i>buildings</i>
AND All Classes	where an internal hydrant is required,

- (b) be located:
1. not more than 4 m from a *required exit* on each floor of the *building* (including the ground floor and adjacent to any *hydrants required* within the *building*); and
 2. so that the nozzle end of a fully extended fire hose fitted to the reel and laid to avoid any partitions or other physical barriers will reach every part of the floor;
- (c) serve only the floor on which they are located except that a hose reel may serve a *sole-occupancy unit* of not more than 2 *storeys*, or a unit with a *mezzanine floor*, if the hose reel is located at the level of egress from that unit; and
- (d) comply with AS/NZS 1221 and NZS 4503.

NE1.6 Portable Fire Extinguishers

Portable fire extinguishers containing an extinguishing agent suitable for the risk being protected must be installed in accordance with NZS 4503 in all *buildings* except:

- (a) a Class 2 or 3 *building*; or
- (b) in the case of water-type extinguishers, a *building* or part of a *building* served by a fire hose reel.

Table NE1.6, overleaf, shows the commonly available portable extinguishers and their selection for appropriate class and type of fires.

NE1.7 Fire and smoke alarms

NE1.7.1 A suitable *automatic* fire and smoke alarm system complying with Specification NE1.7 must be installed in:

- (a) each *storey* if the *building* has a *rise* of 5 to 8 *storeys*;
- (b) a Class 3 *building*:
1. if rooms for residential use are above a height of 2 *storeys*; or
 2. in a special accommodation house or home for the aged, children, sick or physically or mentally persons with disabilities or the like; and
- (c) a Class 9a *building*:

SECTION NE – SERVICES AND EQUIPMENT

1. if more than 20 patients are accommodated in wards or bedrooms; or
2. in a clinic or day surgery, having areas where surgical procedures are performed at a height of 3 storeys or more.

Table NE1.6: Portable Fire Extinguisher Selection Chart

Class and type of fire/ type of extinguisher		Contents of Extinguisher Are			
		Electrically conductive		Electrically non-conductive	
		WATER	FOAM	DRY CHEMICAL	CARBON DIOXIDE
A	Ordinary <i>combustibles</i> (wood, paper, etc.)	✓ YES MOST SUITABLE	✓ YES	✓ YES	✓ YES
B	Flammable liquids	X NO	✓ YES SPECIAL FOAM REQUIRED FOR ALCOLHOL- TYPE FIRE	✓ YES	✓ YES
C	Flammable gases	X NO	X NO	✓ YES	✓ YES
D	Combustible metals	X NO	X NO	X NO	X NO
USE SPECIAL PURPOSE EXTINGUISHERS ONLY					
E	Fire involving live electrical equipment	X NO	X NO	✓ YES	✓ YES

NE1.7.2 A manually operated evacuation alarm system to the relevant provisions of Specification NE1.7 must be provided in any *building* of:

- (a) Class 3 containing more than 20 beds where the rooms for residential use are located up to a height of only 2 storeys;
- (b) Class 5 with a *rise* of 3 or 4 storeys and a *storey floor area* of more than 500 m²;
- (c) Class 6, 7, or 8 excluding a *public carpark* with a *rise* of up to 4 storeys and a *storey floor area* of more than 500 m²;
- (d) Class 9(a) with a *rise* of up to 4 storeys; and
- (e) in the residential part of a school accommodating more than 20 persons at a level above or below the entrance level. Also, in all other class 9b *buildings* (including *schools*) with a *rise* of up to 4 storeys and a *storey floor area* of more than 250 m²; and

Type A, B, or C alarm systems are acceptable for Class 3 *buildings*, Type B or C for Class 6 and 9 other than *schools*, and a Type A system for Class 7 and 8 *buildings* and *schools*.

NE1.8 Fire precautions during construction

In a *building* under construction:

- (a) not less than one fire extinguisher to suit Class A, B, and C fires and electrical fires must be provided at all times on each floor adjacent to each *required exit* or temporary stair or *exit*; and
- (b) after the *building* has reached an *effective height* of 12 m:
 1. the *required hydrants* and hose reels must be operational in at least every *storey* that is covered by the roof or the floor structure above, except the 2 uppermost *storeys*; and
 2. any required fire brigade booster connection must be installed.

NE1.10 Provision for Special Hazards

Suitable additional provision must be made if special problems of fighting fire could arise because of:

- (a) the nature or quantity of materials stored, displayed or used in a *building* or on the allotment, such as occupancies of excessive hazard, all as described in Specification NE1.11; or
- (b) the location of the *building* in relation to a water supply for firefighting purposes.

NE2 Smoke Control

NE2.1 Smoke Venting

Buildings must have a system to control smoke as listed in Table NE2.1.

Table NE2.1 Requirements for Smoke Control

BUILDING	SYSTEM
<i>Sole-occupancy units</i> in Class 2,3 or 4 <i>buildings</i> . Single-storey <i>buildings</i> where the <i>floor area</i> of a <i>fire compartment or storey</i> does not exceed 500 m ² and is not served by a central mechanical ventilation plant.	No requirement
Single-storey <i>buildings</i> , or the top <i>storey</i> of multi-storey <i>buildings</i>	Either: a) <i>Windows</i> , panels or the like in accordance with NE2.3; b) Roof vents in accordance with NE2.5; or c) Smoke exhaust systems in accordance with NE2.6.
Multi-storey <i>buildings</i> excluding the top <i>storey</i>	<i>Windows</i> , panels or the like in accordance with NE2.3.
Class 6 <i>buildings</i> with enclosed malls exceeding 40 m in length	Smoke exhaust systems in accordance with NE2.6.

NE2.2 Exclusion of Smoke from Fire-isolated Exits

Smoke must be excluded from fire-isolated *exits* in accordance with Table NE2.2

Table NE2.2 Means of Excluding Smoke from Fire-Isolated Exits

EXIT TYPE	REQUIREMENT
A <i>required fire-isolated stairway</i> serving any <i>storey</i> above an <i>effective height</i> of 25m. A <i>required fire-isolated stairway</i> serving 3 or more below ground <i>storeys</i> . A <i>required fire-isolated ramp</i> or <i>fire-isolated passageway</i> having a path of travel more than 60 m along it to a road or <i>open space</i> .	Either: a) a pressurization system in accordance with NE2.7; or b) open access ramps or balconies in accordance with ND2.5.
Note: A below-ground <i>storey</i> is one where egress involves an upward vertical climb of more than 1.5 m.	

NE2.3 Natural Smoke Venting

Windows, doors, panels, or the like, provided to control the movement of smoke must:

- (a) be as evenly distributed as practicable; and
- (b) be readily openable, except that if *windows* and panels or the like are provided on the ground-level *storey*, they need only be shatterable.

NE2.4 Air-handling Systems

If an air-handling system is installed in a *building*, it must operate in accordance with Specification NE2.4.

NE2.5 Roof Vents

Required roof vents must comply with AS 2665, except that:

- (a) smoke curtains may divide the space below the roof into compartments with area not more than 1,500 m².
- (b) all roof vents within the same compartment must open at the same time; and
- (c) roof vents must be activated by:
 1. a fire detection and alarm system which complies with AS 1670 or NZS 4512; or
 2. smoke detectors spaced not more than:
 - 30 m apart and 15 m from any smoke curtain and with not less than one detector for each 500 m² of *floor area*; or
 - rate of rise heat detectors spaced not more than 15 m apart and 7.5 m from any smoke curtain and with not less than one detector for each 250 m² of *floor area*.

NE3 Lift Installations

NE3.1 Application of Part

This Part applies to Class 2, 3, 4, 5, 6, 7, 8, and 9 *buildings*.

Lift installations must comply with AS 1735 Parts 1 and 2.

All lifts must be fully *accessible* to wheelchair users, with a minimum internal dimension of 1,100 mm x 1,400 mm deep for lift travelling less than 12 m and 1,400 mm x 1,600 mm deep for those travelling more than 12 m and opening of at least 900 mm. To support users with visual and hearing impairments, lifts should be equipped with tactile buttons, Braille signage, and where practicable audible floor indicators.

NE3.2 Stretcher Facility in Lifts

- (a) If passenger lifts are installed in any *building* with an *effective height* of more than 25 m, at least one lift serving all *storeys* of the *building* must have a stretcher facility in accordance with (b).
- (b) A lift *required* to comply with NE3.2(a) or NE3.4(b) must accommodate a raised stretcher with a patient lying on it horizontally by providing a clear space 600 mm wide x 2,000 mm long x 1,200 mm high above the floor level.

NE3.3 Warning Against Use of Lifts in Fire or Earthquake

A warning sign must:

- (a) be displayed where it can be readily seen:
 1. near every call button panel for a passenger lift or group of lifts throughout a *building*; except
 2. a small lift such as a dumb-waiter or the like that is for the transport of goods only; and
- (b) comply with the details and dimensions of Figure NE3.3 and consist of:

1. incised, inlaid or embossed letters on a metal, wood, plastic or similar plate securely and permanently attached to the wall; or
2. letters incised or inlaid directly into the surface of the material forming the wall.

Figure NE3.3 Warning Sign for Passenger Lifts

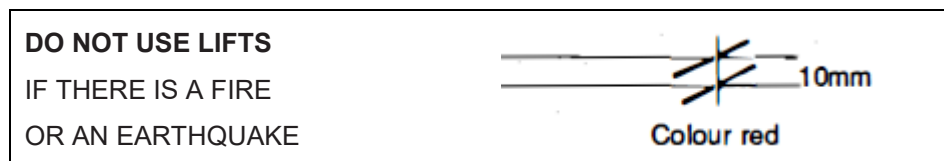

NE3.4 Emergency Lifts

- (a) Among the lifts serving every *storey* of a *building* with an *effective height* of 75 m or more, at least one must be capable of being used as an emergency lift.
- (b) An emergency lift *required* by (a) must:
 - comply with AS 1735.2;
 - be of sufficient size to take a stretcher facility in accordance with NE3.2(b); and
 - have a rating of at least 612 kg.

NE 4 Emergency Lighting, Exit Signs & Warning System

NE4.1 Application of Part

This Part applies to Class 2, 3, 4, 5, 6, 7, 8 and 9 *buildings*.

NE4.2 Emergency Lighting Requirements

An emergency lighting system must be installed:

- (a) in every *fire-isolated stairway*, *fire-isolated ramp* or *fire-isolated passageway* located in Class 2 *buildings* of 5 *storeys* or more, Class 3 *buildings* containing 30 beds or more, a *building* with Class 4 parts located at or higher than 15 m *effective height*, and in all Class 5, 6, 7, 8, and 9 *buildings*;
- (b) in every *storey* of a Class 5, 6, 7, 8, or 9 *building* where the *storey* has a *floor area* more than 500 m²:
 1. in every passageway, corridor, hallway, or the like, which is part of the path of travel to an *exit*;
 2. in any room having a *floor area* more than 250 m² if it does not open to a corridor or space which has emergency lighting;
- (c) in every passageway, corridor, hallway, or the like, having a length of more than 6 m from the entrance doorway of any *sole-occupancy unit* in a Class 2 *building* of 5 *storeys* or more, in a Class 3 *building* containing 30 beds or more, in a Class 4 part located at or above 15 m *effective height*, to the nearest doorway opening directly to:
 1. a fire-isolated stairway, fire-isolated ramp or fire-isolated passageway;
 2. an external stairway serving instead of a smoke or *fire-isolated stairway* under ND1.8;
 3. an external balcony leading to a fire-isolated stairway, fire-isolated ramp or fire-isolated passageway; or
 4. a road or open space;
- (d) in every *required non-fire isolated stairway*, ramp or passageway connecting more than 3 consecutive *storeys* in other than Class 2 *buildings*;
- (e) in a *sole-occupancy unit* in a Class 5, 6, or 9 *building* if:
 1. the *floor area* of the unit is more than 500 m²; and
 2. an *exit* from the unit does not open to a road or *open space* or to an external stairway, passageway, balcony or ramp, leading directly to a road or *open space*;

- (f) in every room or space to which there is public access in every *storey* in a Class 6 or 9b *building* where:
1. the *floor area* in that *storey* is more than 1,000 m²;
 2. any point on the floor of that *storey* is more than 30 m from the nearest doorway opening directly to a stairway, ramp, passageway, road or *open space*;
 3. egress from that *storey* involves a vertical upward climb within the *building* of more than 1.5 m; or
 4. the *storey* provides a path of travel from any other *storey required* by (i), (ii), or (iii) to have emergency lighting;
- (g) in a Class 9a *building*:
1. in every passageway, corridor, hallway, or the like, serving a *ward area* or patient treatment room; and
 2. in every *ward area* or patient treatment room having a *floor area* of more than 200 m².

NE4.3 Measurement of Distance

Distances, other than vertical *rise*, must be the shortest measurement along the corridor or the path of travel whether by straight lines, curves or a combination of both.

NE4.4 Design and Operation of Emergency Lighting

- (a) Emergency lighting systems must:
1. be *automatic* in operation;
 2. provide sufficient illumination without undue delay for safe evacuation of all areas of the *building* where it is *required*;
 3. if it is a central system, be suitably protected from damage by fire; and
 4. operate without interruption for a minimum of 1 hour.
- (b) Emergency lighting in accordance with AS/NZS 2293.1 satisfies (a).

NE4.5 Exit Signs

Exit signs must be installed and be clearly visible to persons approaching the *exit*, on or near:

- (a) every door providing direct egress from a *storey* to:
1. an enclosed stairway, passageway or ramp serving as a *required exit*;
 2. an external stairway, passageway or ramp serving as a *required exit*; and
 3. an external access balcony leading to a *required exit*;
- (b) every door from an enclosed stairway, passageway or ramp at every level of discharge to a road or *open space*;
- (c) every horizontal exit; and
- (d) every door serving as, or forming part of, a *required exit*.

NE4.6 Direction Signs

If the *exits* will not otherwise be readily apparent to persons occupying or visiting the *building*, *exit* signs with directional arrows must be installed in appropriate positions in corridors, hallways, lobbies, and the like, indicating the direction to a *required exit*.

NE4.7 Class 2, 3 and 4 Buildings: Exemptions

NE4.5 does not apply to:

- (a) a Class 2 *building* in which every door referred to is clearly and legibly labelled on the side remote from the *exit* or balcony:
1. with the word “*EXIT*” in capital letters 25 mm high in a colour contrasting with that of the background; or
 2. by some other suitable method; and
- (b) an entrance door of a Class 2, 3, or 4 *sole-occupancy unit*.

NE4.8 Design and Operation of Exit Signs

(a) Every *required exit* sign must:

1. be clear and legible and have letters and symbols of adequate size;
2. be illuminated at a level sufficient for it to be clearly visible at all times when the *building* is occupied by any person having the right of legal entry to the *building*;
3. be installed so that if the normal power;
4. supply fails, emergency illumination is provided to the sign in the case of those *buildings* covered by NE3.2; and
5. if illuminated by an emergency lighting system incorporating wiring and a power source, comply with NE4.4.

(b) Exit signs in accordance with AS/NZS 2293.1 satisfy (a).

NE 5 Inspection, Test & Maintenance of Safety Installations

NE5.1 Application of Part

This Part applies to Class 2, 3, 4, 5, 6, 7, 8, and 9 *buildings*.

NE5.2 Maintenance Requirements

Safety installations in *buildings* must be adequately maintained to the requirements of Table NE5.2.

Table NE5.2: Schedule of Maintenance

Item to be inspected or tested	Nature of inspection and/or test, and frequency
1. Opening protection	
A <i>required</i> fire door, fire <i>window</i> , fire shutter or smoke door	Operate and inspect for compliance with the provisions of Part NC3 and Specification NC3.4 Monthly
2. Means of egress	
(a) Exits and paths of travel including doors, doorways, and exit signs	Inspect to ensure compliance with Section ND Monthly
(b) Required handrails and balustrades	Annually
(c) Arrangements for safe egress in <i>buildings</i> with special security provisions	Monthly
3. Signs	
(a) Signs concerning use of lifts in the event of fire	Inspect for legibility and installation in compliance with Part NE4 Annually
(b) <i>Exit</i> sign illumination: internally illuminated signs	Check that the lamp matches the approved lamp rating marked on the sign fitting Monthly
(c) externally illuminated signs	Check that the illumination is adequate Monthly
4. Emergency lighting	

SECTION NE – SERVICES AND EQUIPMENT

Item to be inspected or tested	Nature of inspection and/or test, and frequency
<i>Required</i> emergency lighting	(a) Operate in conditions of simulated failure of power to the distribution board concerned and check for compliance with the provisions of Part NE4 Monthly (b) Where batteries are involved: Test and inspect as prescribed in AS 1670 as though they are installed pursuant to the provisions of that standard or where AS 1670 is not relevant, test or inspect as appropriate Monthly (c) Check battery charger for correct operation Monthly
5. Firefighting services & equipment	
<i>Required</i> portable fire extinguishers <i>Required</i> fire hose reels <i>Required</i> hydrants and riser main system	As prescribed in NZS 4503 As prescribed in NZS 4503 As prescribed in NZS 4503
6. Air-handling systems	
(a) Simulate activation of detectors	Operate and check for correct operation in accordance with specification NE2.4 and NE2.6. Ensure that the system is left in correct operating condition all as in NZS 4512
(b) Detectors Associated batteries	Test and inspect as though they are prescribed for installations under NZS 4512 Check battery charger for correct operation all as in NZS 4512
(c) Fire situations	Check to ensure compliance with AS 1668.1 Annually
(d) Fire-control panels	Test and inspect as though the panel is installed as a fire indicator board under NZS 4512
(e) Pressurizing of stairs, ramps and passageways	Operate, test and inspect to ensure compliance with AS 1668.1 Monthly
7. Manual fire alarms	
8. Automatic fire alarms	
(a) <i>Required</i> <i>automatic</i> alarms (b) Special situations and precautions and outdoor applications	As prescribed in NZS 4512 Inspect for compliance with NZS 4512
9. Lifts	
Lifts and associated equipment for operation in event of emergency	Operate under simulated emergency conditions and check for compliance with the provisions of NE3 Quarterly
10. Structural fire protection	

Item to be inspected or tested	Nature of inspection and/or test, and frequency
Compartmentation and fire protection of <i>structural members</i>	Ascertain that any work performed or any occurrence, accidental or otherwise, has not resulted in any reduction in the FRL or other fire protection provision of any part of the <i>building</i> installed as <i>required</i> Annually

NE6 Electrical Work

NE6.1 Electrical Safety

NE6.1.1 General requirements

All electrical wiring and installations in or on any Class 2 to 9 *buildings* must ensure safety from electric shock and fire. This requirement is satisfied if all electrical work associated with the *building* is done to comply with AS/NZS 3000: Electrical installations: *buildings*, structures, and premises (known as the SAA Wiring Rules). The capacity of the system must allow for the long term anticipated requirements of the occupants.

NE6.1.2 Plug sockets

Plug sockets must:

- (a) have their individual switch;
- (b) be located so that:
 - 1. cords need not be taken across doorways;
 - 2. trailing cords do not have to cross circulation routes;
- (c) not be located behind door-swings; and
- (d) in the kitchen be located 250 mm above worktops at the back of benches or on a return wall where it exits.

NE6.1.3 Meter and distribution board

The meter must be located in a position from which it can easily be read. If the main switches and circuit breakers/fuses are not located with the meter they must be located at a height of not less than 1.8 m from the floor where they can be found easily in the dark.

NE6.1.4 Photovoltaic Energy System

All photovoltaic energy systems shall fully comply with the requirements of AS/NZS 5033. Photovoltaic panel systems shall be fixed to the main structure of the *building*. Fixings shall be designed in accordance with the requirements of Section B: Structure.

NE6.2 Amenity

NE6.2.1 Light switch layout

- (a) The layout of light switches must follow the main nighttime circulation routes such as from the entrance hall to the living area to the bedrooms to the bathroom and toilet. Crossing any major space in the dark must be avoided. The switches must be located close to door openings.
- (b) All stairs must have two-way switching at the top and the bottom.

SPECIFICATION NE1.2

Fire Mains and Water Supply Services

Contents

1 Scope	14
2. General requirements	14
3. Fire pump enclosures	15
4. Booster and charged dry riser main connections and cabinets	15

1. Scope

This Specification refers to *fire mains* and water supply services for firefighting equipment in *buildings*.

2. General Requirements

A fire main must:

- be capable of supplying water at the flow rates and pressures necessary for the satisfactory operation of the *required* fire-fighting equipment;
- not incorporate plastic pipes above ground; and
- not be used for other than firefighting purposes except a *fire main* serving only hose reels may be connected to a metered supply if:
 - the *required* flow rate and pressure can be maintained at the most hydraulically disadvantaged hose reel;
 - the water meter and street supply to the allotment have a nominal diameter of not less than 32 mm;
 - water supply pipework reticulation arrangements comply with Figure 2 or a similar arrangement; and
 - any system valve which can isolate flow in the *fire main* is secured in the open position by a padlocked metal strap.

Figure 2: Water Supply Reticulation: Combined Services

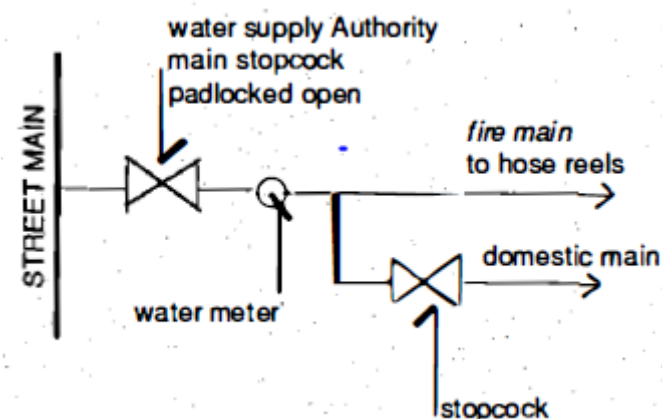

3. Fire Pump Enclosures

Fire pumps must be located in a room or enclosure which has an FRL of not less than 60/60/30 and is:

1. within the *building*; or
2. external but not within 6 m of the *building* and any *fire-source feature*.

4. Booster and Charged Dry Riser Main Connections and Cabinets

- (a) Each *fire brigade booster connection* and the fire service inlet connection for a *charged dry riser main system* must be in locked cabinets accessible only to the fire service. If the system is fitted with a pressure gauge, the gauge must comply with AS 1271, and have a full-scale reading of not less than 25% more than the pressure to which the system has been hydrostatically tested.
- (b) Cabinets may be located:
 1. at the *external wall* of a *building* if they are within sight of the main entrance and for Class 6, 7, 8, or 9b *buildings*, separated from the *building* by construction having an FRL of not less than 60/60/30 for not less than 2 m each side of and above the top of the cabinet;
 2. remote from the *building* if they are at the boundary of the allotment, within sight of the main entrance to the *building*, adjacent to the principal vehicular access to the allotment and located not less than 10 m. from the *external wall* of any *building*; or
 3. in any other suitable position.
- (c) A permanent fade and water-resistant plan, equal to photo-engraved anodized aluminium, must be displayed in a prominent position within the cabinet, showing the following information:
 1. the layout of the *building* and adjacent streets;
 2. the layout of the *fire-hydrant* system;
 3. reticulation, with supply authority street mains and size, location of street and allotment *hydrants*, fire hose reels, booster connections, street and allotment isolating- and non-return valves, pumps, and tanks;
 4. the operational discharge pressure and pressure at zero flow of any pump installed in the system;
 5. the capacity of any tank connected to the system;
 6. the height of the highest *hydrant* outlet above the lowest booster inlet connection, and
 7. the year of installation of the system.
- (d) Suitable provision must be made for the drainage of water from within a booster or *charged dry riser main system* cabinet.

SPECIFICATION NE1.7

Fire Detection and Alarm Systems

Contents

1. Scope	16
2. Automatic systems	16
2.1 Purpose	16
2.2 Connection to Extinguishing Systems	16
2.3 Location of Smoke Detectors	16
2.4 Threshold Levels	17
3. Manually operated evacuation, fire alarm systems.....	17

1. Scope

This Specification describes the installation and operation of *automatic* fire detection and alarm systems, and manually operated evacuation alarm systems. The *automatic* systems may also be used to operate a smoke control system within a *building*.

2. Automatic Systems

An *automatic* fire detection and alarm system must comply with AS 1670 Parts 1, 3, 4 & 5 or NZS 4512 subject to this Specification.

2.1 Purpose

The purpose of a fire detection and alarm system is to:

- (a) warn the occupants of any fire within the *building*;
- (b) alert the local Fire Service;
- (c) activate any installed *automatic* smoke control system; and
- (d) provide for manual operation as an evacuation system.

2.2 Connection to extinguishing systems

Systems designed to AS 1670 Parts 1, 3, 4 & 5 or NZS 4512 for the actuation of any fire extinguishing system must operate on a dual circuit to permit *automatic* operation of an evacuation alarm.

2.3 Location of smoke detectors

Smoke detectors must be:

- (a) wherever possible, surface mounted and external to air conditioning and ventilation ducts, unless a point-sampling system with maximum sensitivity level of 0.5% smoke obscuration is used;
- (b) located at natural collection points for hot smoke having regard to the ceiling geometry and its effects on the migratory path;
- (c) situated no closer than 3 m from smoke doors or fire doors; and
- (d) of the photo-electric type if installed within ducts or atmospheres contaminated with sub-micron dust and other particles likely to set off an ionization-type detector.

2.4 Threshold levels

- (a) Sampling systems must comply with AS 1670, with response times and alarm thresholds maintained at minimum levels and no alarm delay permitted on the highest alarm threshold.
- (b) The setting of alarm threshold levels for addressable detectors used within intelligent systems must not exceed the sensitivity levels nominated in:
 - AS 1668.1; and
 - AS 1670 Parts 1, 3, 4 & 5 or NZS 4512.

3. Manually Operated Evacuation, Fire Alarm Systems

(a) *Required* manually operated evacuation alarm systems must comply with AS 1670 Parts 1, 3, 4 & 5 or NZS 4512 for installation, operation, and maintenance. The three systems considered are:

Type A: Simple mechanical means;

Type B: Simple electrical system, not monitored; and

Type C: Electrical systems continuously monitored by connection to the fire service station.

- (b) When Type B systems are installed, the following warning notice must be clearly marked near each manual call point:

NOT CONNECTED TO A FIRE SERVICE IN CASE OF FIRE PHONE

showing the telephone number of the fire authority in the locality.

Type B systems may be substituted with a self-contained battery-operated system, provided care is taken to ensure that the battery has sufficient charge available at all times.

(c) Location

Manual call points must be located not more than:

- for Class 3 *buildings*, 20 m from the doorway of any *sole-occupancy unit*;
- for Class 5,6,7, 8 and 9b *buildings*, 20 m travel distance from any point on the floor; and
- for Class 9a *buildings*:
 - 12 m from any point of the floor of a *ward area*; or
 - 6 m from the entrance doorway of any room which may be occupied by a sleeping, sedated, or dependent patient.

SPECIFICATION NE1.11

Occupancies of Excessive Fire Hazard

Contents

1. Scope	18
2. Ordinary Hazard Occupancies	18
3. Extra High Hazard Occupancies	18

1. Scope

This specification contains a graded list of examples of excessive fire hazard. The examples do not cover all possibilities and therefore there could be many other occupancies of excessive fire hazard. The Fire Authority having jurisdiction must be consulted in case of any doubt about occupancies not included in this Annexure.

2. Ordinary Hazard Occupancies

Group III Special

Flash fires are likely to occur in these occupancies. These include the following:

- Chemical works and chemists (manufacturing or analytical) producing or using flammable solids, liquids, dusts and the like
- Copra kilns
- Cork factories
- Cotton mills (preparatory processes)
- Distilleries (stillhouses)
- Exhibitions
- Fiberglass products manufactures
- Film and television studios
- Flax and hemp scutch mills
- Flax, jute, and hemp mills (preparatory processes)
- Match factories
- Oil mills (crushing and solvent extraction)

3. Extra High Hazard Occupancies

Process risks

Examples of extra high hazard process risks are as follows:

- Aircraft hangars
- Celluloid manufacturers and celluloid goods manufacturers
- Fire lighter manufacturers
- Fireworks manufacturers
- Floor cloth and linoleum manufacturers
- Foam plastics and foam plastics goods manufacturers and warehouses
- Foam rubber and foam rubber goods manufacturers and warehouses
- LPG bulk storage
- Paint, colour, and varnish works
- Resin, lamp black and turpentine manufacturers
- Rubber substitute manufacturers
- Tar distillers

- Woodwool manufacturers

High Piled Storage Risks

Extra high hazard high piled storage risks are subdivided into four categories. Fires in materials belonging to categories II, III and IV produce exceptionally intense fires with a high rate of heat release. The four categories are:

(a) Category I. Category I comprises ordinary *combustible* materials and *non-combustible* materials in *combustible* wrappings, excluding those items specified under Categories II, III and IV, stored in bulk, in pallets or on racking, to heights exceeding 4 m. Examples of Category I storage are as follows:

- i. Carpets
- ii. Clothing
- iii. Electrical appliances
- iv. Fibreboard (high-density Hardboard)
- v. Glassware and crockery (in cartons)
- vi. Groceries (items not packaged)
- vii. Metal goods (in cartons)
- viii. Textiles
- ix. All forms of paper storage other than those specified under Categories II and III

(b) Category II: Examples of Category II storage are as follows:

- i. Aerosol packs with flammable contents
- ii. Baled cork
- iii. Baled wastepaper
- iv. Cartons and carton flats
- v. Cartons containing alcohols in cans or bottles
- vi. Cartons of canned lacquers which dry by solvent evaporation
- vii. Chipboard
- viii. Fibreboard (low density soft board)
- ix. Linoleum products.
- x. Palletized whisky stocks
- xi. Plastics (non-foamed) other than celluloid (horizontal storage)
- xii. Rolled pulp and paper (horizontal storage)
- xiii. Rolled asphalt paper (horizontal storage)
- xiv. Veneer sheets
- xv. Wood patterns
- xvi. Wooden furniture

(c) Category III: Examples of Category III storage are as follows:

- i. Bitumen coated or wax coated paper
- ii. Celluloid
- iii. Esparto (loose)
- iv. Flammable liquids in *combustible* containers
- v. Foamed plastics and foamed rubber products (with or without cartons) other than those specified in Category IV
- vi. Rolled pulp and paper (vertical storage)
- vii. Rolled asphalt paper (vertical storage)
- viii. Rubber goods
- ix. Ventilated wood *stacks*
- x. Waxed or asphalt-coated paper and containers in cartons
- xi. Woodwool
- xii. Wooden pallets and wooden flats (idle)
- xiii. All materials having wrappings or preformed containers of foamed plastics

(d) Category IV: Examples of Category IV storage are as follows:

- i. Rolls of sheet foamed plastics or foamed rubber
- ii. Off-cuts and random pieces of foamed plastics or foamed rubber

SPECIFICATION NE2.4

Air Handling Systems in Buildings

Contents

1. Scope	20
2. Commonly used systems	20
3. Action on detection of smoke fire or flame	20
4. Compliance.....	20

1. Scope

This Specification outlines the performance and operation of mechanical ventilation and air conditioning systems as they relate to smoke control in *buildings*.

2. Commonly Used Systems

The following commonly used systems may be installed:

- (a) small stand-alone or *window* units without ducting;
- (b) central chilled water systems with fan coil units located in each *storey* without any ducting;
- (c) central chilled water systems with separate air handling plants in each *storey* or *fire compartment* and associated independent ducting for the *storey* or *fire compartment*;
- (d) individual packaged plants and associated ducting for each *storey*; or
- (e) central plant where all the conditioning is done and with the ducting system connecting several *fire compartments* or *storeys*.

3. Action on Detection of Smoke Fire or Flame

In the case of small units, the power supply to the units must be switched off manually. With all other systems immediately on activation of any of the detection units:

- (a) the total system for the whole *building* must shut down;
- (b) any *required exit* pressurization system must operate; and
- (c) any *required* smoke exhaust system or smoke-and heat vent must operate.

4. Compliance

The action *required* under 3(a), (b) or (c) must be *automatic* and be activated by:

- (a) smoke detectors located in each store or *fire compartment* in accordance with Specification NE1.8 and with ducted systems, located just upstream of the supply fan as well as in the main return air duct; or
- (b) by any other suitable fire alarm system installed within the *building*.

SPECIFICATION NE2.6

Smoke Exhaust Systems

Contents

1. Scope	21
2. Fan Capacity	21
3. Compartmentation at Ceiling Level	22
4. Location of Fans and Discharge.....	22
5. Make-up Air	22
6. Operation of Fans	22
7. Protection of Wiring	23
8. Resistance to High Temperatures	23

1. Scope

This Specification describes the performance and method of operation of smoke exhaust systems in *buildings* which are designed to:

- (a) remove smoke from within the *building* using ducted or roof mounted exhaust fans; or
- (b) in a shopping center complex or mall, remove smoke from within pedestrian malls to maintain for as long as possible a tenable escape path for the occupants.

2. Fan Capacity

Fan systems must have an exhaust capacity in accordance with the height of the *building* as specified in Figure 2.

Figure 2: Exhaust Capacity of Fans

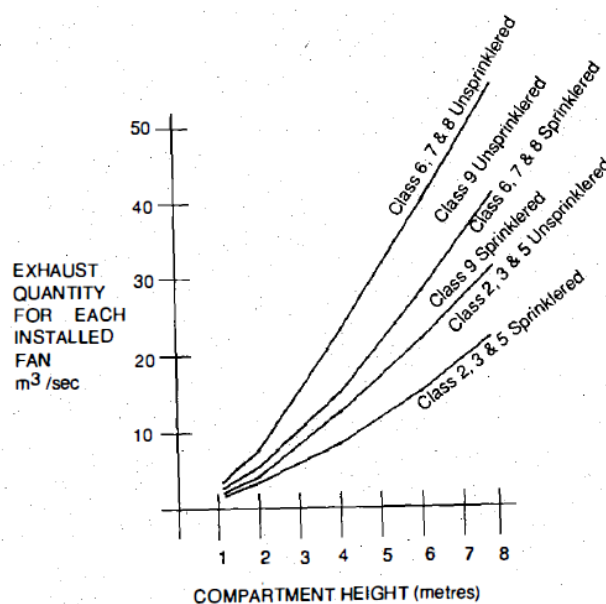

3. Compartmentation at Ceiling Level

The *storey* or room at ceiling level:

- (a) must be divided into compartments not more than 1,500 m² in area by smoke curtains in accordance with AS 2665; or
- (b) in a shopping center complex or mall, must have:
 - 1. smoke curtains or, toughened or wired glass or *non-combustible* bulkheads, which extend not less than 1 m beneath an imperforate ceiling; or
 - 2. ceiling coffers not less than 500 mm deep, each containing a smoke exhaust fan, across the full width of the mall to divide it into lengths of not more than 40 m.

4. Location of Fans and Discharge

Exhaust fans must be located so as not to cause undue turbulence, and:

- (a) in a shopping center complex or mall:
 - 1. be spaced no more than 40 m apart and not more than 20 m from the end of the mall;
 - 2. not be at a mall intersection unless there is an open area where the ceiling is raised not less than 2 m above the ceiling in the mall; and
 - 3. be located at natural collection points for the hot smoky gases within each smoke compartment having regard to the ceiling geometry and its effects on the migratory path of the smoke;
- (b) in other *buildings* be located so that each fan must serve not more than one 1,500 m² root compartment; and
- (c) discharge directly to the outside and in a manner that will not spread fire or smoke to adjacent fire compartments or *buildings*.

5. Make-up Air

Low-level fresh-air inlet openings or doors must be sized to provide adequate low-velocity fresh air make-up to satisfy the exhaust performance of the installed smoke exhaust fans, care being exercised in the number and location of such openings and their disturbance of the smoke layer due to turbulence created by the incoming air.

6. Operation of Fans

All smoke exhaust fans must start sequentially and be activated by the operation in the area served by the fan of:

- (a) a fire detection and alarm system which complies with Specification NE1.7;
- (b) a detector system comprising:
 - 1. smoke detectors spaced not more than 30 m apart and 15 m from any curtain, bulkhead or wall and with not less than one detector for each 500 m² of *floor area*; or
 - 2. rate-of-rise heat detectors spaced not more than 15 m apart and 7.5 m from any curtain, bulkhead or wall and with not less than one detector for each 250 m² of *floor area*,and not less than 2 detectors located on opposite sides of each fan inlet, or
- (c) in a shopping center complex or mall:
 - 1. optical smoke detectors in each smoke compartment with at least one detector for each 150 m² of *floor area*, arranged in at least 2 groups so that on activation of an alarm group in the respective smoke compartment full exhaust is initiated, and on activation of a second group and following a 30-second check period, an alarm is transmitted to the fire *service station*; and
 - 2. a manual break-glass alarm at each *exit* from a shop with a *floor area* of more than 1,000 m² arranged to activate the exhaust system and transmit an alarm to the Fire Brigade.

7. Protection of Wiring

Power supply wiring for roof-mounted exhaust fans must be MIMS (copper) cable or otherwise suitably fire-protected where it passes through other *storeys* and might be affected by fire remote from the floor served by the plant.

8. Resistance to High Temperatures

If not adequately shielded from the airflow:

(a) all parts of exhaust fans and other equipment *required* to operate in a smoke-laden environment;
and

(b) parts of the *building required* to be smoke-resisting,

must be capable of withstanding a temperature of 200°C for a period of not less than 1 hour.

Section



HEALTH & AMENITY

THIS SECTION APPLIES TO PUBLIC
BUILDINGS AND GROUP DWELLINGS
(CLASS 2 to CLASS 9)

Contents

PERFORMANCE REQUIREMENTS	1
OBJECTIVES	1
NFP1 Damp and weatherproofing	1
NFP2 Cooking and sanitary facilities	1
NFP3 Room sizes.....	1
NFP4 Light and ventilation	1
NFP5 Water supply plumbing.....	1
NFP6 Sanitary plumbing	1
NFP7 Roof drainage	1
NFP9 Site drainage	1
REQUIRED PERFORMANCE	2
NFP1.1 Damp and weatherproofing.....	2
NFP2.1 Cooking and sanitary facilities	2
NFP3.1 Room sizes.....	2
NFP4.1 Light and ventilation	2
NFP5.1 Water supply plumbing.....	2
NFP6.1 Sanitary plumbing and drainage	2
NFP7.1 Roof drainage	3
NFP8.1 Site drainage	3
DEEMED-TO-SATISFY PROVISIONS	4
NF1 Damp and Weatherproofing	4
NF 1.1 Floor levels and site drainage	4
NF1 .2 Building on land subject to dampness or flooding	4
NF1.4 Weatherproofing of roofs and walls	4
NF1.5 Pliable roof sarking	4
NF1.6 Waterproofing of wet areas in buildings	4
NF1.7 Damp-proof courses.....	5
NF1.8 Acceptable damp-proof courses.....	5
NF1.9 Damp-proofing of floors on the ground	5
NF2 Sanitary and other Facilities	5
NF2.1 Facilities for Residential Buildings Other Than Class 1 and 10	5

SECTION NF – HEALTH AND AMENITY

NF2.2 Calculation of number of occupants and fixtures.....	6
NF2.3 Facilities in class 4 to 9 buildings	6
NF2.4 Facilities for people with disabilities.....	8
NF2.5 Construction of sanitary compartments	9
NF2.6 Interpretation: urinals and washbasins.....	9
NF3 Room Sizes	9
NF3.1 Height of rooms.....	9
NF3.2 Reduced height permissible.....	10
NF3.3 Ceiling fans	10
NF 4 Light and Ventilation.....	10
NF4.1 Provision of natural light	10
NF4.2 Methods and Extent of Natural Lighting	10
NF4.3 Natural Light Borrowed from Adjoining Room.....	10
NF4.4 Artificial Lighting.....	11
NF4.5 Ventilation of Rooms	11
NF4.6 Natural Ventilation	11
NF4.7 Ventilation Borrowed from Adjoining Room.....	11
NF4.8 Restriction on Position of WCs and Urinals	12
NF4.9 Airlocks.....	12
NF4.10 Sub-floor Ventilation.....	12
NF4.11 Public Carparks	13
NF4.12 Uncovered Space for Class 4 Parts.....	13
NF4.13 Ventilation of Specialized Areas	13
NF4.14 Indoor Air Quality.....	13
NF4.15 Room Temperature	13
NF4.16 Ventilation.....	13
NF4.17 Air Conditioning.....	14
NF4.18 Mould Prevention.....	15
NF5 Water Supply Plumbing.....	15
NF5.1 General Requirements.....	15
NF5.2 Means of compliance	15
NF5.3 Pipe which are not easy to access	15
NF5.4 Access to domestic-type water heaters.....	15
NF6 Sanitary Plumbing And Drainage	16
NF6.1 General requirements.....	16
NF6.2 Means of compliances.....	16

SECTION NF – HEALTH AND AMENITY

NF6.3 Certain floors to be drained..... 16

NF6.4 Grease trap 16

NF7 Sanitary Disposal 16

NF7.1 Specific requirements..... 16

NF7.2 Commercial, Institutional and Large Scale Residential 17

NF7.3 Resorts and Hospitals..... **Error! Bookmark not defined.**

NF7.4 Industrial Sewage and Wastewater Disposal 17

NF7.5 Small treatment plants 18

NF8 Roof Drainage 18

NF8.1 General Requirements..... 18

NF8.2 Means of Compliance..... 18

SPECIFICATIONS

SPECIFICATION NF8.2: Sizing of Gutters and Downpipes

PERFORMANCE REQUIREMENTS

OBJECTIVES

A *building* must be designed and constructed to meet the following objectives:

NFP1 Damp and weatherproofing

Suitable damp and weatherproofing must be provided where necessary to prevent:

- (a) moisture or damp affecting the stability of the *building*;
- (b) the creation of any unhealthy or dangerous condition; or
- (c) causing damage to adjoining property.

NFP2 Cooking and Sanitary Facilities

Adequate toilet and washing facilities must be provided for the occupants of a *building*, having regard to its use and size. In residential *buildings* other than those meant for transient occupants, suitable facilities must also be available for the preparation and cooking of food, the cleaning of utensils and the laundering of clothes.

NFP3 Room Sizes

The *floor area*, plan dimensions and ceiling heights of rooms and other spaces within a *building* must be adequate for their use or purpose.

NFP4 Light and Ventilation

The standard of light and ventilation within a *building* must be adequate for the occupants, having regard to the use or purpose of the *building*.

NFP5 Water Supply Plumbing

An appropriate safe and hygienic system of plumbing for the supply of water for domestic needs must be provided.

NFP6 Sanitary Plumbing

An appropriate system of drainage for the hygienic waterborne conveyance of *wastewater* must be provided.

NFP7 Sanitary Disposal

An appropriate system of treatment for the hygienic waterborne disposal of *wastewater* must be provided.

NFP8 Roof Drainage

Where a roof drainage system is provided, it must give reasonable protection against the overflow of rainwater into the *building*.

NFP9 Site Drainage

Unhealthy ponding of water in the allotment must not be allowed and the erection of the *building* or any *alteration* to it must not adversely affect the drainage of other allotments or of any public land.

REQUIRED PERFORMANCE

NFP1.1 Damp and Weatherproofing

Water and damp conditions must not be allowed to:

- (a) affect the stability of *buildings*;
- (b) create ill health or discomfort for the occupants;
- (c) damage or deface *buildings* as a result of moisture present at the completion of construction;
- (d) cause damage to adjacent property; or
- (e) pond surface water against *buildings* or beneath the floor.

NFP2.1 Cooking and Sanitary Facilities

Any cooking facility provided must not spread smoke which may affect health or create a nuisance to the occupants or neighbours. Washing and clothes-laundry facilities provided in residential *buildings* must be consistent with the size and occupancy of the *building*. The standard of toilet and washing facilities provided must in any *building* not create a nuisance or lead to ill health to the occupants or neighbours. These facilities must be located conveniently and the number of units provided must be consistent with the size and class of occupancy. Smoke extraction units from kitchens and other process operations in Class 6, 8, or 9 *buildings* must ensure that the progressive build-up of soot, grease and the like does not lead to a fire or unhealthy conditions.

NFP3.1 Room Sizes

The size and disposition of rooms in a *building* must be consistent with the requirements of health and hygiene.

NFP4.1 Light and Ventilation

Lighting via artificial or natural means shall be adequate for occupants at day or night. Where no mechanical ventilation is provided natural ventilation openings shall be adequate for the intended occupancy of the *building*.

Where air-handling systems are provided in a *building*, there must be adequate provision for natural ventilation to cater for any prolonged failure of the system.

NFP5.1 Water Supply Plumbing

Plumbing for potable water supply must use materials which do not react with the water and thereby make it unsuitable. Suitable precautions must be taken to ensure that unsafe or unhygienic materials have no chance of entering the supply system. The installation of hot water systems must not impair the safety of the users. All concealed and difficult-to-access plumbing work must be suitably protected so that there is no likelihood of damage and leakage. The plumbing must take into account the current and anticipated needs of the user and allow for the simultaneous use of the connected system by others.

NFP6.1 Sanitary Plumbing and Drainage

Sanitary plumbing must be laid to self-cleansing grades consistent with their discharge loading, unless other suitable arrangements are made to ensure that the system is kept free of the accretion of *sewage* and other waste matter. The size of *drains* and the layout of their connections must reasonably ensure the current and anticipated needs of the users. The connections to sanitary installations must ensure that foul gases are not allowed to produce unhygienic conditions nor create any nuisance to anyone and are suitably vented.

NFP7.1 Sanitary Disposal

An appropriate sanitary treatment system shall be designed such that:

1. disease transmitting flies and other insects do not have access to the excreta;

2. there is no nuisance to the public or the neighbours;
3. the subsoil water is not polluted if it is likely to be used for domestic purposes;
4. the biological oxygen demand (BOD) of any resulting effluent is limited to the requirements of the Department of Health so that streams rivers and oceans are not polluted; and
5. it is safe and usable for all users, with adequate access to inclusive facilities.

NFP8.1 Roof Drainage

The roof drainage system must be capable of handling peak intensities of rainfall as follows:

- (a) Eaves gutters and downpipes: a 20-year return intensity.
- (b) Internal box gutters, valley gutters and downpipes: a 100-year return intensity.

Any known local variation in rainfall intensity must be taken into account. Sufficient allowance must be made for the possibility of overflow into the *building* due to ripples and turbulence in the flowing water during cyclonic winds.

NFP9.1 Site Drainage

The immediate *site* around the *building* must have suitable drainage so that no ponding results. Visible water must not be allowed to remain under or around for more than 1 hour after 10 minutes of maximum rainfall resulting from a storm with a return period of 5 years. *Flood* waters or waves resulting from a storm or cyclone with a return period of 30 years must not be allowed to enter a *building*.

DEEMED-TO-SATISFY PROVISIONS

NF1 Damp and Weatherproofing

NF1.1 Floor Levels and Site Drainage

Floor levels of all new *buildings* must be a minimum of 500mm above the natural ground level and, where possible, the ground around the *building* must slope away from the *building* at a minimum fall of 1 in 100 for two meters.

The construction of the site drainage system and the position and manner of discharge of a stormwater drain must not:

- (a) result in the entry of water into any *building* or other allotments;
- (b) affect the stability of any *building*; or
- (c) create any unhealthy or dangerous condition within or around any *building*.

Stormwater Drainage must be designed according to AS/NZ 3500.3.

NF1.2 Building on Land Subject to Dampness or Flooding

One or all of the following measures must be carried out if it is warranted by the dampness of the *building* site or proneness to *flooding*:

- (a) The subsoil must be adequately drained.
- (b) The ground under the *building* must be regraded or filled and provided with outlets to prevent accumulation of water.
- (c) The surface of the ground under the *building* must be covered with a suitable damp-resisting material.

The *building* or structure floor level shall not be less than 500 mm above the known *flood* level at the site plus sea level rise for a median high emissions (SSP3-7.0) projection to the design working life or the *flood hazard level* as per B1.6.NF1.3 Drainage of land external to *building*.

A suitable system of drainage must be provided if paving, excavation or any other work on an allotment will cause undue interference with the existing drainage of rainwater falling on the allotment whether the existing drainage is natural or otherwise.

NF1.4 Weatherproofing of Roofs and Walls

Roofs and *external walls* (including openings for *windows* doors and the like) must be constructed to prevent rain or dampness penetrating to the inner parts of a *building*, unless it is:

- (a) a Class 7, 8, or 10 *building* and in the particular case, there is no necessity for compliance;
- (b) a garage, tool shed, *sanitary compartment*, or the like, forming part of a *building* used for other purposes; or
- (c) an *open spectator stand* or open deck carpark.

NF1.5 Pliable Roof Sarking

Pliable roof *sarking-type material* used under roof or wall coverings must comply with AS/NZS 4200.1.

NF1.6 Waterproofing of Wet Areas in Buildings

The following parts of a *building* must be impervious to water:

- (a) in any *building*: the floor surface or substrate in a shower enclosure, or within 1.5 m measured horizontally from a point vertically below the shower fitting if there is no enclosure;

- (b) in a Class 3, 5, 6, 7, 8, or 9 *building*, the floor surface or substrate in a bathroom or shower room, slop sink compartment, laundry, or *sanitary compartment* which is used in common by the occupants.
- (c) the wall surface or substrate:
 - 1. of a shower enclosure, or if the shower is not enclosed, within 1.5 m and exposed to a shower fitting, to a height of 1.8 m above the floor;
 - 2. immediately adjacent or behind a bath, trough, basin, sink, or similar fixture, to a height of 300 mm above the fixture if it is within 75 mm of the wall;
- (d) the junction between the floor and wall if the wall and floor are *required* to be impervious to water.
- (e) the junction between the wall and fixture if the wall is *required* to be impervious to water.

NF1.7 Damp-proof Courses

Except in a *building* that is exempt from weatherproofing under NF1.4, moisture from the ground must be prevented from reaching:

- (a) the lowest floor timbers and the walls above the lowest floor joists;
- (b) the walls above the damp-proof course; and
- (c) the underside of a suspended floor constructed of a material other than timber, and the supporting beams or girders.

NF1.8 Acceptable Damp-proof Courses

A damp-proof course must consist of:

- (a) a material that complies with AS/NZS 2904;
- (b) suitable termite shields placed on piers; or
- (c) other suitable material.

NF1.9 Damp-proofing of Floors on the Ground

If a floor of a room is laid on the ground or on filling:

- (a) moisture from the ground must be prevented from reaching the upper surface of the floor and adjacent walls by:
 - 1. the insertion of a vapour barrier in accordance with AS 2870; or
 - 2. other suitable means; and
- (b) damp-proofing need not be provided if the *building* is exempt from weatherproofing under NF1.4.

NF2 Sanitary and other Facilities

NF2.1 Facilities for Residential Buildings Other Than Class 1 and 10

Sanitary and other facilities for Class 2 and 3 *buildings*, and Class 4 parts of *buildings*, must be provided in accordance with Table NF2.1.

Table NF2.1 Provision of Sanitary and Other Facilities

CLASS OF BUILDING AND MINIMUM FACILITIES REQUIRED
<p>Class 2 Within each sole-occupancy unit</p> <p>(a) A kitchen sink and facilities for the preparation and cooking of food</p> <p>(b) A shower; and</p> <p>(c) A closet pan and facilities for washing hands.</p> <p>Class 2 For each building</p> <p>(a) A separate laundry for each 4 <i>sole-occupancy units</i>, or part without its own clothes washing facilities, comprising at least one washtub and space for a washing machine</p> <p>(b) Clothes drying facilities comprising:</p> <ol style="list-style-type: none"> 1. Lines or clothes hoists with not less than 7.5 m of line per <i>sole-occupancy unit</i>; or 2. One heat-operated drying cabinet or appliance for each 4 <i>sole-occupancy units</i>, or part, without its own drying facilities. <p>Class 2 Facilities for employees</p> <p>If the <i>building</i> contains more than 32 <i>sole-occupancy units</i>, or if a group of Class 2 <i>buildings</i> on the one allotment contains in total, more than 32 <i>sole-occupancy units</i>, then provide a closet pan and washbasin in a compartment or room at or near ground level and accessible to employees without having to entering a <i>sole-occupancy unit</i>.</p>
<p>Class 3 Facilities for residents</p> <p>For each 10 residents (male and/or female) for whom private facilities are not provided:</p> <ol style="list-style-type: none"> 1. A shower; and 2. A closet pan and washbasin, except that if one urinal is provided for each 25 males up to 50 and one additional urinal for each additional 50 males or part thereof, then one closet pan for each 12 males may be provided. <p>If these facilities are situated outside the <i>building</i>, they should be conveniently accessible.</p>
<p>Class 4 For each sole-occupancy unit</p> <p>(a) a kitchen sink and facilities for the preparation and cooking of food;</p> <p>(b) a shower;</p> <p>(c) a closet pan and washbasin;</p> <p>(d) clothes washing facilities, comprising a washtub and space in the same room for a washing machine; and</p> <p>(e) a clothesline or hoist, or space for a heat-operated drying cabinet or similar appliance for the exclusive use of the occupants.</p>

NF2.2 Calculation of Number of Occupants and Fixtures

The number of persons accommodated must be calculated according to Table ND1.13 if it cannot be more accurately determined by other means.

Unless the premises are predominantly used by one sex or numbers of male and female users are known, sanitary facilities must be provided equally for both sexes.

In addition, where the nature of employment of an employee is such that a shower is highly desirable at the end of the work (e.g., cooks and kitchen hands), showers must be provided for each 10 such male or female employee in any one shift.

NF2.3 Facilities in Class 4 to 9 Buildings

Sanitary facilities must be provided in Class 4, 5, 6, 7, 8, and 9 *buildings* in accordance with Table NF2.3.

SECTION NF – HEALTH AND AMENITY

Table NF2.3: Sanitary and Other Facilities

Class of building	User	Max number served by:									
		Closet fixture(s)			Urinal(s)			Washbasin(s)			
		1 Up to	2 Up to	Each extra	1 Up to	2 Up to	Each extra	1 Up to	2 Up to	Each extra	
5, 6, and 9 other than schools	Employees										
	Males	20	40	20	25	50	50	60	120	60	
	Females	15	30	15	-	-	-	60	120	60	
7 and 8	Employees										
	Males	20	40	20	25	50	50	30	60	30	
	Females	15	30	15	-	-	-	30	60	30	
6. Department stores, shopping centers and, individual shops in excess of 900 m ² total floor area	Patrons										
	Males	500	2,400	1,200	600	1,200	1,200	1,000	4,000	2,000	
	Females	300	600	1,200	-	-	-	1,000	4,000	2,000	
6. Restaurants, cafes, bars, public halls, function rooms and 9a. Out-patients	Patrons										
	Males	50	200	250	50	200	100	50	200	250	
	Females	30	70	80	-	-	-	50	200	250	
9a. Healthcare buildings (Other than for out-patients)	Resident patients										
	Males	-	20	10	-	-	-	16	32	16	
	Females	-	20	10	-	-	-	16	32	16	
Other facilities: provide 1 shower and 1 laundry point for every 40 inpatients plus and 1 hand washing facility at every toilet block and treatment area.											
9b. Schools not being early childhood centers	Staff and employees										
	Males	20	40	20	25	50	50	30	60	30	
	Females	20	40	20	-	-	-	30	60	30	
	Students at day schools										
	Males	35	70	35	30	70	40	100	200	100	
	Females	25	50	25	-	-	-	100	200	100	
	Other facilities: Provide 1 tap stand for drinking water for every 50 students.										
	Students at boarding schools										
	Males	35	70	35				100	200	100	
Females	25	50	25				100	200	100		

SECTION NF – HEALTH AND AMENITY

Class of building	User	Max number served by:								
		Closet fixture(s)			Urinal(s)			Washbasin(s)		
		1 Up to	2 Up to	Each extra	1 Up to	2 Up to	Each extra	1 Up to	2 Up to	Each extra
		Other facilities: Provide 1 tap stand for drinking water for every 50 students, 1 shower for up to 40 students (separated by gender) and 1 laundry facility for every 50 students. For urban boarding schools allow 1 urinal for every 50 male students.								
9b. Early childhood centers	Children	-	30	15	-	-	-	-	30	15
		Other facilities: One shower must be provided.								
9b. Sporting venues, theaters, cinemas, art galleries or the like and churches, chapels, or the like	Participants at sporting venues, theaters, or the like									
	Males	20	40	20	10	20	10	20	40	20
	Females	15	30	15	-	-	-	20	40	20
	Other facilities: One shower for each 10 or part, participants.									
	Spectators or patrons									
	Males	250	500	500	100	200	100	250	500	500
Females	75	250	250	-	-	-	250	500	500	

NF2.4 Facilities for People with Disabilities

Sanitary facilities must be provided in accordance with Table NF2.4 in every Class 3, 5, 6, 7, and 9 building that is required by Part ND3 to be accessible to people with disabilities.

Table NF2.4: Sanitary Facilities for People with Disabilities

Class of building and minimum facility for use by people with disabilities	
Class 3: In every <i>sole-occupancy unit</i> to which access for people with disabilities is <i>required</i> : (a) One closet pan and washbasin; and (b) One shower.	
Class 5, 6, 7 and 9 buildings with <i>floor area</i> more than 1,000 m ² and Class 3 if accommodation is other than in <i>sole-occupancy units</i> , or other parts of the <i>building</i> are <i>required</i> to be <i>accessible</i> .	
Number of persons for whom total facilities normally required	Minimum number for use by people with disabilities
Closet pans plus urinals	
1–100	One unisex facility; or One closet pan and washbasin for each sex
101–200	Two unisex facilities; or One closet pan and washbasin for each sex and one unisex facility
More than 200	Two unisex facilities or one closet pan and washbasin for each sex and one unisex facility; and One additional unisex facility or one closet pan and washbasin for each sex for each additional 100 people.

Class of building and minimum facility for use by people with disabilities	
In all cases, facilities for females must include adequate means for the disposal of sanitary towels	
Bath or shower	One shower or shower-bath for each 10 people or part thereof normally <i>required</i> , but not less than one for use by both sexes.

NF2.5 Construction of Sanitary Compartments

- (a) Partitions: Other than in any *early childhood center*, *sanitary compartments* must have doors and partitions must separate adjacent compartments and extend:
1. from floor level to the ceiling in the case of a unisex facility; or
 2. to a height of not less than 1,500 mm above the floor if primary *school* children are the principal users, or 1,800 mm above the floor in all other cases.
- (b) Facilities for people with disabilities: The construction and layout of *sanitary compartments* for use by people with disabilities must comply with the guidelines set out in the Australian Department of Foreign Affairs (DFAT): *Accessibility Design Guide: Universal Design principles for Australia's Aid Program: Annex A: Built Environment* (Available free of charge DFAT website).

At a minimum, sanitary compartments shall:

1. have doors that are a minimum 850 mm clear width and preferably open out or slide;
2. have a minimum dimension of 2 m high and 1.6 m x 2.4 m or 2.0 m x 2.7 m if a shower or bath is included;
3. have handrails at a minimum height of between 800 mm and 1 m, and have a firmly fixed grip rail next to the toilet, 800 mm high; and
4. have firmly fixed washbasins to the wall at a height of between 800 mm and 850 mm, with the centerline at least 450 mm from an adjacent wall.

NF2.6 Interpretation: Urinals and Washbasins

- (a) Urinals shall be designed to minimize the exposure of concrete to urine either through the sealing of the concrete and/or through the use of stainless steel, fiberglass, and plastic materials. A urinal may be either:
1. an individual stall or wall hung urinal;
 2. each 600 mm length of a continuous urinal trough; or
 3. a closet pan used in place of a urinal.
- (b) A washbasin may be either:
1. an individual basin; or
 2. a part of a hand wash trough served by a single water tap.

NF3 Room Sizes

NF3.1 Height of Rooms

Minimum heights below the ceiling and any framing excluding minor projections such as cornices, are:

- (a) Class 2, or 3 *buildings*, or Class 4 parts:
1. habitable room: 2.4 m;
 2. laundry or the like: 2.1 m; and
 3. corridor or passageway: 2.1 m.
- (b) Class 5, 6, 7, and 8 *buildings*:
1. areas other than in (ii): 2.4 m; and
 2. corridor, passageway, or the like: 2.1 m.
- (c) Class 9a *building*:
1. ward area: 2.4 m;
 2. operating theatre or delivery room: 3.0 m; and

3. treatment room, clinic, waiting room, passageway, corridor, or the like: 2.4 m.
- (d) Class 9b *buildings*:
1. *school* classroom or other *assembly building* or part that accommodates not more than 100 persons: 2.4 m; and
 2. theatre, public hall or other *assembly building* or part that accommodates more than 100 persons: 3.0 m.
- (e) Ancillary and other spaces:
1. bathroom, shower room, water closet, toilet room, airlock, tea preparation room, pantry, storeroom, garage, carparking area, or the like, in any class of *building*: 2.1 m.

NF3.2 Reduced Height Permissible

These heights may be reduced if the reduction does not unduly interfere with the proper functioning of the room in:

1. attic rooms;
2. rooms with a sloping ceiling or projection below ceiling line; or
3. other rooms or spaces.

NF3.3 Ceiling Fans

Ceiling fans and other such appliances must be at a minimum vertical clearance of 2.1 m.

NF 4 Light and Ventilation

NF4.1 Provision of Natural Light

Natural lighting must be provided in:

- (a) Class 2 *buildings* and Class 4 parts: to all *habitable rooms*;
- (b) Class 3 *buildings* to all bedrooms and dormitories;
- (c) Class 9a *buildings*: to all rooms used for sleeping purposes; and
- (d) Class 9b *buildings*: to all general purpose classrooms in primary or secondary *schools* and all playrooms or the like for the use of children in an *early childhood center*.

NF4.2 Methods and Extent of Natural Lighting

Direct natural lighting must be provided by *windows* that:

- (a) have an aggregate light transmitting area measured excluding framing members, glazing bars or other obstructions of not less than 10% of the *floor area* of the room;
- (b) face:
 1. a court or other space open to the sky; or
 2. an open verandah, open carport, or the like;
- (c) are not less than a horizontal distance from any adjoining allotment, or a wall of the same *building* or another *building* on the allotment that they face, that is the greater of:
 1. in a Class 2, 3, or 9 *building* or a Class 4 part: 1 m;
 2. in a *ward area* or other room used for sleeping purposes in a Class 9a *building*: 3 m; and
 3. 50% of the square root of the height of the wall in which the *window* is located, measured in meters from its sill.

NF4.3 Natural Light Borrowed from Adjoining Room

Natural lighting to a room in a Class 2 or 4 *building*, or in a *sole-occupancy unit* of a Class 3 *building* may come through a glazed panel or opening from an adjoining room (including an enclosed veranda) if:

- (a) in a Class 2 or 3 *building* or Class 4 part, both rooms are within the same *sole-occupancy unit* or the enclosed veranda is on common property;
- (b) the glazed panel or opening has an area of not less than 10% of the *floor area* of the room to which it provides light; and
- (c) the adjoining room has *windows* with an aggregate light transmitting area of not less than 10% of the combined *floor areas* of both rooms.

The areas specified in (b) and (c) may be reduced as appropriate if direct natural light is provided from another source.

NF4.4 Artificial Lighting

Artificial lighting must be provided:

- (a) in *required* stairways and ramps by means of separate electrical wiring circuits from the main switchboard for the exclusive use of the stairway or ramp; and
- (b) if natural lighting of a standard equivalent to that *required* by NF4.2 is not available and the periods of occupation, or use of the room or space will create undue hazard to occupants seeking egress in an emergency, in:
 - 1. Class 4 parts: to *sanitary compartments*, bathrooms, shower rooms, airlocks and laundries;
 - 2. Class 2 *buildings*: to *sanitary compartments*, bathrooms, shower rooms, airlocks, laundries, common stairways and other spaces used in common by the occupants of the *building*; and
 - 3. Class 3, 5, 6, 7, 8, and 9 *buildings*: to all rooms that are frequently occupied and all corridors, lobbies, internal stairways, other circulation spaces and paths of egress.

NF4.5 Ventilation of Rooms

- (a) A *habitable room*, office, shop, factory, workroom, *sanitary compartment* bathroom, shower room, laundry and any other room occupied by a person for any purpose must have adequate flow-through or cross-ventilation and air quality, including sufficient air-changes and fresh air quantities.
- (b) Provision of either:
 - 1. natural ventilation complying with NF4.6; or
 - 2. a mechanical ventilation or air conditioning system complying with AS 1668.2, with provision for natural ventilation to NF4.6 for use in case of a lengthy failure of the mechanical system, satisfies (a).

Where the *required* ventilation relies on mechanical or air-conditioning systems, *habitable rooms*, offices, shops, factories, workrooms or commercial laundries must have alternate natural ventilation for use in case of a lengthy failure of the mechanical system. The extent of natural ventilation available must be not less than 25% of that *required* under NF4.6. Otherwise, the mechanical system must have a complete stand-by system including for power generation.

NF4.6 Natural Ventilation

Required natural ventilation must be provided by permanent *windows*, openings, doors or other devices:

- (a) with an aggregate opening or openable size not less than 10% of the *floor area* of the room *required* to be ventilated; and
- (b) which open to:
 - 1. a court, or space open to the sky; or
 - 2. an open verandah, open carport, or the like.

NF4.7 Ventilation Borrowed from Adjoining Room

Natural ventilation to a room may come through a *window*, opening, ventilating door or other device from an adjoining room (including an enclosed verandah) if both rooms are within the same *sole-occupancy unit* or the enclosed verandah is common property, and:

- (a) in a Class 2 *building*, a *sole-occupancy unit* of a Class 3 *building* or a Class 4 part of a *building*:
 - 1. the room to be ventilated is not a *sanitary compartment*;

2. ventilation is not borrowed from one bedroom to another or between a bedroom and the kitchen;
 3. the *window*, opening, door or other device has a ventilating area of not less than 10% of the *floor area* of the room to be ventilated; and
 4. the adjoining room has a *window*, opening, door or other device with a ventilating area of not less than 10% of the combined *floor areas* of both rooms.
- (b) in a Class 5, 6, 7, 8, or 9 *building*:
1. the *window*, opening, door or other device has a ventilating area of not less than 10% of the *floor area* of the room to be ventilated, measured not more than 3.6 m above the floor; and
 2. the adjoining room has a *window*, opening, door or other device with a ventilating area of not less than 10% of the combined *floor areas* of both rooms; and
- (c) the ventilating areas specified in (a) and (b) may be reduced as appropriate if direct natural ventilation is provided from another source.

NF4.8 Restriction on Position of WCs and Urinals

A room containing a closet pan or urinal must not open directly into:

- (a) a kitchen or pantry;
- (b) a public dining room or restaurant;
- (c) a dormitory in a Class 3 *building*;
- (d) a room used for public assembly; or
- (e) a workplace normally occupied by more than one person.

NF4.9 Airlocks

If a room containing a closet pan or urinal is prohibited under NF4.8 from opening directly to another room:

- (a) in a *sole-occupancy unit* in a Class 2 or 3 *building* or in a Class 4 part:
 1. access must be by an airlock, hallway or other room; or
 2. the room containing the closet pan or urinal must be provided with an exhaust fan; and
- (b) in a Class 5, 6, 7, 8, or 9 *building* (which is not an *early childhood center*, *primary school*, or *open spectator stand*):
 1. access must be by an airlock, hallway or other room with a *floor area* of not less than 1.1 m² and fitted with *self-closing* doors at all access doorways; or
 2. the room containing the closet pan or urinal must be provided with mechanical exhaust ventilation and the doorway to the room adequately screened from view.

NF4.10 Sub-floor Ventilation

- (a) Suitable provision must be made to prevent undue deterioration of the lowest floor of a *building* because of dampness, other conditions on the allotment or the design of the *building*.
- (b) The following would satisfy the requirements of (a):
 1. where timber is used, the floor framing must be suspended with an absolute minimum of 250 mm and an average minimum of 400 mm clearance from the ground underneath to the floor and the immediate surrounds of the *building*. The average clearance must be determined as the average of the clearances at the corners of a 3 m square grid covering the *building*. Subfloor ventilation must be provided with ventilation openings totalling not less than 3% of the peripheral vertical area between the ground and the boundary of the floor. These openings are to be spaced uniformly and at not more than 1.8 m apart.
 2. where other than timber is used:
 - a) subfloor ventilation must be provided if the floor is suspended;
 - b) an impervious cover provided over the ground surface beneath the *building*; or the floor members suitably treated.

NF4.11 Public Carparks

Every *storey* of a *public carpark* must have:

- (a) a mechanical ventilation system complying with AS 1668.2; or
- (b) a suitable system of permanent natural ventilation in accordance with NF4.6.

NF4.12 Uncovered Space for Class 4 Parts

Class 4 parts of *buildings* must have sole access to a space open to the sky of 20 m² minimum area. Of this, at least 5 m² must be at the same level as the Class 4 part and the rest may be at either 3 m above or 3 m below.

NF4.13 Ventilation of Specialized Areas

Where the *building* contains areas or rooms that are not covered elsewhere in this Section, systems shall be provided in compliance with AS 1668:2. This includes (but is not limited to) areas such as commercial kitchens, rubbish rooms, cleaners, cupboards, and healthcare rooms.

NF4.14 Indoor Air Quality

Buildings must have a means of collecting and/or removing the following from the rooms in which they are generated:

- (a) cooking fumes and odours;
- (b) excessive water vapor from laundering, utensil washing, bathing and showering;
- (c) odours from sanitary and waste storage spaces;
- (d) gaseous by-products and excessive moisture from commercial or industrial processes;
- (e) poisonous fumes and gases;
- (f) air-borne particles; and
- (g) products of combustion.

Contaminated air must be disposed of in a way that avoids creating a nuisance or hazard to people and other property.

NF4.15 Room Temperature

Achieving a comfortable indoor temperature may be achieved through any, some, or all of the following:

- (a) insulation in walls, ceilings, floors, attic spaces to prevent heat, electricity, or sound from passing into or out of a room or structure;
- (b) high performance window glazing;
- (c) natural ventilation;
- (d) external shading of windows and proper window coverings;
- (e) high-efficiency fans in living and attic spaces;
- (f) energy efficient mechanical air conditioning system.

Release of heated air to the outside must be provided by the use of any, some or all of the following natural ventilation techniques, unless the *building* is fully air-conditioned by a mechanical system:

- (a) high ceilings (greater than 2.2 m);
- (b) windows/vents within 250 mm of the ceiling.

NF4.16 Ventilation

Ventilation systems in non-residential *buildings* must be equipped with:

- (a) exhaust outlets and plumbing vents a minimum of 6.0 m away from outdoor air intakes;
 - (b) outdoor air intakes located at least 9.0 m away from sources of pollution including dumpsters, parking areas, driveways, loading docks, natural gas lines, wet cooling towers and garage doors / exhaust outlets;
 - (c) outdoor air intakes must be protected with suitable mesh screens and filters; and
 - (d) roof drainage that slopes away from outdoor air intakes;
- and must:
- (e) account for the demands of any fixed combustion appliances; and
 - (f) be sized and configured to accommodate future expansion of the *building*.

Natural ventilation must consist of permanent openings, windows, doors, or other devices that can be opened and are of sufficient size and appropriately placed to provide effective air circulation.

Openings must be placed on all façades, where appropriate to the function and use of the rooms, *building*, and must be screened to prevent entry of birds, rodents, leaves, and other similar objects.

Larger openings must be placed on the downwind, or leeward, facade, and smaller openings on the breeze, or windward, facade to promote air circulation within the *building*.

Non-air-conditioned *buildings* must have the majority of windows consist of louvred panels or other openable panels to promote air flow, as appropriate to occupancy and use.

Enclosed attic spaces and cathedral ceilings must have adequate ventilation such that they:

- (a) provide adequate cross-ventilation of enclosed attic spaces and enclosed cathedral ceilings;
- (b) provide exhaust fans where needed.

NF4.17 Air Conditioning

A mechanical air-handling system installed in a *building* must control:

- (a) the circulation of objectionable odours;
- (b) the accumulation of harmful contamination by micro-organisms and pathogens; and
- (c) be in accordance with AS 1668.2 and AS/NZS 3666.1.

Air conditioning units must have an appropriate energy-savings certificate from a recognized agency, such as Energy Star and must have suitable corrosion protection for the environment it is located in.

Ducts must be appropriately sized for room-to-room cooling requirements and to maximize efficiency, with the layout designed to reduce duct length as much as possible.

Ducts must be properly sealed with low volatile organic compound (VOC) mastic so that ductwork is airtight (duct tape is not permitted).

Rooms must have adequately sized return ducts or doors that are undercut sufficiently to allow air flow to avoid any situation of negative pressure.

Effective delivery of clean supply air must be sufficiently provided to reduce the impact of pollutants generated in the interior spaces.

Mechanical air conditioning systems must have any or all of the following energy-saving equipment to control the volume of cooled air produced daily and promote energy efficiency:

- (a) variable speed controls;
- (b) timer switches for rooms to control air temperature according to time of day and use of the *building*;
- (c) demand-controlled ventilation that adjusts outdoor air intake to maintain optimal indoor air quality;
or
- (d) isolate fan motors from supply air streams.

Mechanical air handling equipment must have air filtration suitable for the application required.

All air conditioning systems are to undergo a commissioning process to ensure the functional and environmental performance.

NF4.18 Mould Prevention

Cross-ventilation through the *building* interior must be provided through appropriate layout of rooms, and placement and size of doors, windows and vents.

Buildings with air conditioning must have positive air pressure to promote proper air circulation.

Methods for prevention of water accumulation listed in NF1 above must be followed.

Stand-alone sanitary compartments not connected to a bathroom, laundry or other sanitary room must provide ventilation through either a window or mechanical ventilation (see Part NF4.5).

NF5 Water Supply Plumbing

NF5.1 General Requirements

The plumbing work for water supply must ensure:

- (a) the appropriateness of the materials and products used;
- (b) the correct sizing of water services for the intended use;
- (c) the control of cross-connections and prevention of backflow;
- (d) adequate care in the installation of the services;
- (e) suitable provision of main and subsidiary storage as required;
- (f) adequate connections to sanitary services without endangering health and hygiene; and
- (g) the installation of hot water system to provide safe and adequate service.

NF5.2 Means of Compliance

The requirements of NF5.1 are satisfied if all plumbing for water supply is carried out to the relevant provision of:

- (a) AS 3500: Part 1 for cold water service;
- (b) AS 3500: Part 4 for hot water service; and
- (c) AS/NZS 2845.1 Water Supply Backflow Prevention Devices: Part 1: Materials, Design and Performance Requirements and its amendments.

NF5.3 Pipes that Are Not Easy to Access

Particular attention is drawn to the provisions in AS 3500: Parts 1 and 4, which prohibit the installation of pipes and fittings of certain materials in locations which are concealed or difficult to access. These include pipe made of ABS, galvanized steel, polybutylene, and UPVC. Pipes and fittings made of copper, copper alloy, stainless steel, ductile iron, cast iron and polyethylene when used in concealed or difficult to access locations must follow the special precautions specified in AS 3500: Parts 1 and 4.

NF5.4 Access to Domestic-type Water Heaters

- (a) A household water heater which is installed in a *building* must:
 - 1. be supported on construction sufficient to carry its full capacity weight and any possible wind or earthquake loads;
 - 2. be positioned to enable adequate access for operation, maintenance and removal; and
 - 3. provide suitably for any overflow, especially if installed in a concealed location.
- (b) AS 3500: Part 4 is the relevant standard for the installation of a household water heater.

NF6 Sanitary Plumbing and Drainage

NF6.1 General Requirements

Sanitary plumbing and drainage must ensure:

- (a) the appropriateness of the products and materials used;
- (b) the correct sizing of drainage services for the intended use;
- (c) adequate care in the installation of the services including the provision of appropriate grades;
- (d) that foul gases are not allowed to produce unhygienic conditions or any nuisance to anyone; and
- (e) adequate maintenance and sludge removal contracts for commercial, institutional, large developments, resorts and hospital and industrial systems.

NF6.2 Means of Compliance

The requirements of NF6.1 are satisfied if all sanitary plumbing and drainage works are carried out to the relevant provisions of AS 3500: Part 2: Sanitary plumbing and sanitary drainage.

NF6.3 Certain Floors to Be Drained

In a Class 2, 3, or 4 Part *building*, the floor of each bathroom and laundry in a *sole-occupancy unit* which is located at other than the lowest level must be graded to permit drainage to a floor waste gully.

NF6.4 Grease Trap

Where the nature of the occupancy is such that the wastewater contains grease, fats or oils to levels unacceptable to the Authority having jurisdiction, a suitable grease trap must be installed. The accumulated grease and oils must be removed at intervals sufficient to prevent their escape into the disposal system. After removal the grease and oils must be suitably disposed of.

NF7 Sanitary Disposal

NF7.1 Specific Requirements

Sanitation facilities must ensure:

- (a) no discharge of wastewater of any kind to surface water;
- (b) no discharge to a soil surface that is:
 - 1. less than 1.5 meters above maximum groundwater level; or
 - 2. less than 15 meters from a downstream (coastward) drinking groundwater source;
- (c) the maximum design loading to a soil surface shall not exceed:
 - 1. 50 mm per day for septic tank effluent.
 - 2. 70 mm per day for secondary or better treated effluent.
- (d) the effluent distribution system shall achieve a uniform application at or less than the maximum design loading rate;
- (e) system chosen is in accordance with Specifications DF7.1;
- (f) percolation tests are mandatory for Institutional *Buildings*, Resorts and Hospitals and Industrial systems to determine a safe infiltration area;
- (g) for slopes greater than 6° (1:10 vertical to horizontal) that display evidence of any undulations, hummocks, tension cracks, scarps, terraces, soil creep, land slippage, surface erosion, subsurface erosion (“under-runners”) or any other form of land movement, land deformation, settlement, subsidence or erosion, a site-specific geotechnical investigation of the site proposed for an on-site wastewater management system must demonstrate that the site proposed for the septic tank is unlikely to be subject to slope instability or that the tank will not induce slope instability (such an

- assessment must be carried out by a *professional consultant*);
- (h) site inspection by an *appropriately qualified person* and standard special designs are required for Class 2 and 10 *Buildings*;
 - (i) where a sewage treatment plant is designed, a maintenance and sludge removal contracts are required; and
 - (j) there should be a contract for sludge removal from septic tanks for commercial and large development, as well as resorts and hospitals.

NF7.2 Commercial, Institutional and Large Scale Residential; Resorts and Hospitals

The method, design and construction of the treatment plants and disposal facilities for commercial, institutional and large-scale residential developments shall be certified by a *professional consultant* and shall include disposal of effluent by means of irrigation onto land where sufficient land is available. NF7.4 provides further information where land is not sufficient.

Considerations to combine urinal wastewater with grey wastewater for public *buildings* are encouraged in the designs for public *buildings*.

NF7.2.1 Performance Standards

Designers and owners of sewage treatment plant must:

- (a) require the undertaking of an environmental impact assessment (EIA) and the preparation of an environmental management and monitoring plan (EMMP); and
- (b) have either of the following:
 - (i) for a septic tank with a soil absorption system: a contract for sludge removal.

Sludge removal from septic tanks within urban areas shall be undertaken at least every 4 years, and at least every 8 years elsewhere. Where more frequent emptying of septic sludge occurs, owners should seek to reduce the greywater / rainwater ingress to the septic tank or increase the size of the soil absorption system. Evidence of the surcharge of effluent to surface is considered a system failure necessitating the immediate rehabilitation of the soil absorption system.

- (ii) for a sewage treatment plant that discharge to a soil absorption system: a minimum of two contracts for system maintenance (at least quarterly) and sludge removal (at least yearly).

Effluent from sewage treatment plants referred to NF7.2 shall conform with the following performance standards (before the soakaway):

1. Five Day Biochemical Oxygen Demand (BOD₅) shall not exceed 100 mg/l (one monthly measurement annual means not to exceed).
2. Suspended Solids (SS) shall not exceed 100 Mg/l (one monthly measurement annual means not to exceed).
3. Faecal Coliforms (FC) shall be less than 10,000 MPN/100 ml for 95% of the time (based on monthly measurements taken over an annual period).

Evidence of the surcharge of effluent to surface from the soil absorption system or overflow is considered a system failure, necessitating the immediate rehabilitation of the soil absorption system (and the causal conditions leading to this failure).

NF7.2.2 Prohibitions

The following practices shall be prohibited:

- Direct discharge of treated effluent to marine waters.
- Treated effluent shall not be discharged into open pits or trenches.
- Sewage from septic tanks shall not be disposed of to unlined landfill to protect the groundwater.

NF7.3 Industrial Sewage and Wastewater Disposal

All developments shall comply as a minimum with the Approved Treatment and Disposal methods.

Performance Criteria and Prohibitions as specified for Commercial, Institutional, and Large-Scale Residential *Buildings* in Clause NF7.2.

In addition to these criteria, the following are required:

1. the industrial site shall be inspected by an *appropriately qualified person*;
2. a certified design for the disposal of industrial waste shall be prepared by a *professional consultant*;
3. there shall be no discharge of industrial wastewater effluent, treated or untreated, direct to ground if any adverse environmental effect may occur from such a discharge or if there is uncertainty whether such an adverse environmental effect may or may not occur;
4. performance standards for sewage effluent from resorts and hospitals shall be met, including testing, maintenance, and sludge-emptying contracts;
5. implementation of the certified design shall be inspected and approved in writing by an *appropriately qualified person* during and on completion of construction.

NF7.4 Small Treatment Plants

The details given in **Specification DF7.1B** may be used for the preliminary design of the main elements of a septic tank system with enhanced effluent soakage / sand filtering systems, if such a system is considered.

Where a septic tank system does not suit, in particular because nutrients have to be reduced further before disposal, an *appropriately qualified person* shall be engaged to design appropriate treatment system, including:

1. Packaged treatment plants such as Innovative / Alternative Onsite Wastewater Treatment System; or
2. Any other suitable method, following AS/NZS 1547 (On-site domestic wastewater management), and AS/NZ 1546 Part 3 (Guidance on the design and installation of 'On-site domestic wastewater treatment units: Aerated wastewater treatment systems').

NF8 Roof Drainage

NF8.1 General Requirements

Gutters and downpipes, where provided, must have sufficient capacity to reasonably prevent the overflow of rainwater into the *building*. The peak intensities of rainfall that the gutters and associated downpipes must be able to handle are as follows:

- (a) Eaves gutters: the 20-year return intensity.
- (b) Box and valley gutters: the 100-year return intensity.
- (c) Gutters and downpipes for temporary *building*: the 5-year return intensity of rainfall.

Eaves gutters other than for temporary *buildings* must have a designed freeboard of 25 mm and box gutters, 35 mm.

NF8.2 Means of Compliance

The requirements of NF7.1 are satisfied if the requirements of AS/NZS 2179: Metal rainwater goods: Specification and AS/NZS 3500 Parts 2 and 3: Plumbing and Drainage: Stormwater Drainage, are met. **Specification NF8.2** covers some of these requirements.

SPECIFICATION NF8.2

Sizing Of Gutters and Downpipes

Contents

1. Design Criteria.....	20
2. Catchment.....	20
3. Eaves Gutter.....	21
3.1 Size.....	21
3.2 Slope.....	22
3.3 Leaf Guards and Overflows.....	22
3.4 Proportion.....	22
4. Internal Box Gutters.....	22
4.1 Size of Gutter.....	22
4.2 Size of Downpipe.....	25
4.3 Overflow.....	26
4.4 Rain Heads.....	26
4.5 Sumps.....	26
5. Downpipes.....	27
5.1 Location.....	27
5.2 Swirl.....	27
5.3 Gratings.....	27
6. Incompatible Materials.....	27
7. Expansion Joints for Gutters.....	27
9 Stormwater.....	27
9.1 Downpipe discharges into a storm water gully.....	27
9.2 Pipe sizes.....	28

1. Design Criteria

The design of a roof-drainage system is based on the following factors:

1. rainfall intensity and risk of *flooding*;
2. catchment area of roof;
3. gutter efficiency; and
4. spacing of downpipes.

Rainfall Intensity

In rainstorms, long periods of steady rainfall are interspersed with peak intensities for short periods. The roof-drainage system must be able to handle the peak intensities without *flooding* or overflow.

The 5-year return intensity is used in the design of temporary structures of short life. The design of eaves gutters of permanent *buildings* must be based on the 20-year return intensity and of internal box gutters and valley gutters on the 100-year return intensity. The values of these intensities for representative areas in the country may be ascertained from the Vanuatu Meteorology & Geo-hazards Department. A freeboard of 25 mm for eaves gutters and of 35 mm for internal box gutters and valley gutters are *required* to provide against overflow into buildings.

2. Catchment

A roof drainage system is best analyzed by dividing it into lengths of gutter, each sloping down from a high point to an outlet with a downpipe. A long length of roof usually *drains* into several lengths of gutter separated by expansion joints that are also high points. The catchment area for a length of gutter is determined by multiplying the rafter length by the length of gutter (G) and adding a proportion of any vertical surface against which rain can be driven. A reasonable procedure is to add half the area of a very exposed vertical surface and smaller proportions for less extreme conditions (see Figure 2.1).

Figure 2.1: Effect of Vertical Surface on Catchment

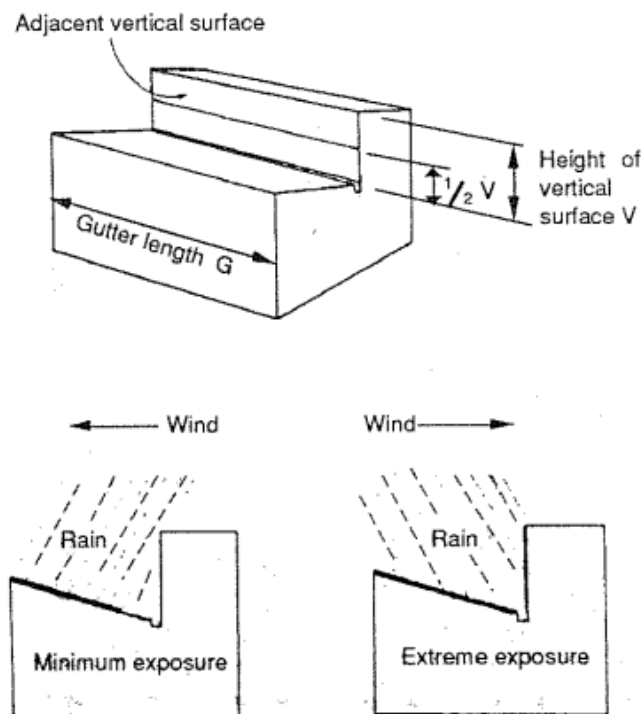

The length G of a gutter is measured as the distance from a high point in the gutter to the downpipe when the downpipe is at the end of the gutter and between high points when the downpipe is not at the end (see Figure 2.2).

Figure 2.2: Measuring Gutter Length

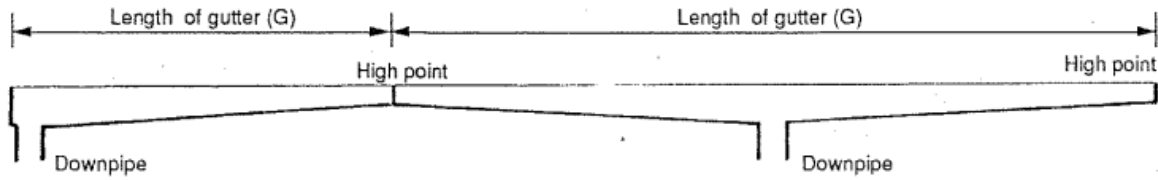

3. Eaves Gutter

The procedure for the design of eaves gutters is as follows:

3.1 Size

Space the downpipes suitably and calculate the catchment area per downpipe. For eaves gutters of permanent *buildings*, determine the gutter discharge area by matching the catchment area against the 80 mm/hr intensity line in Figure 3.1. If the gutter discharge area obtained is more than what is available from a standard gutter after allowing for a 25 mm freeboard, either reduce the spacing of the downpipes and recalculate or proceed to specify a specially fabricated gutter. With rectangular fabricated gutters, an additional allowance of 10% of the area must be made in addition to the freeboard allowance.

The net cross-sectional area of each vertical downpipe, including the nozzle must be not less than 50% of the gutter discharge area.

Figure 3.1: Eaves Gutter Sizing

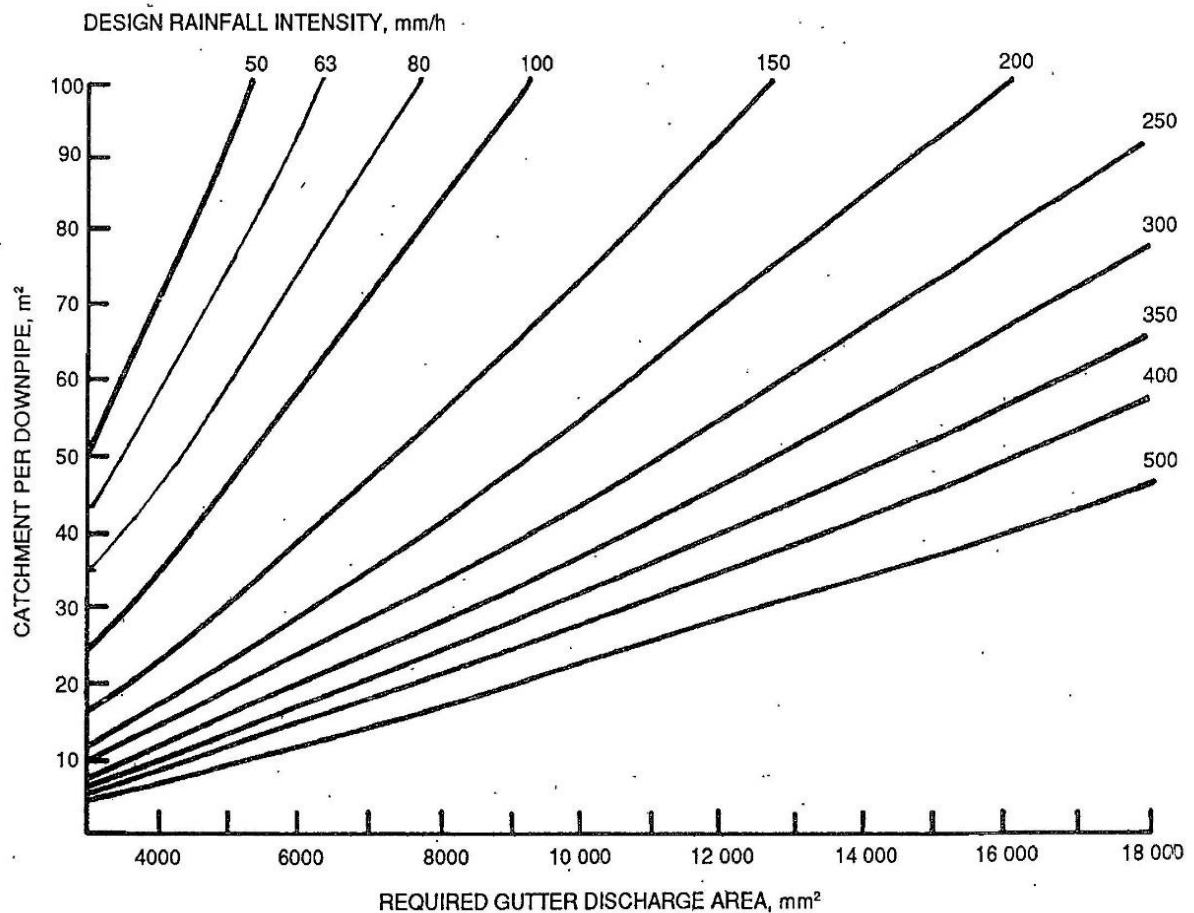

3.2 Slope

The fall of an eaves gutter must never be less than 1 in 500 but in areas where dust or debris is likely to build up between rain periods, the slope must be as steep as 1 in 50.

3.3 Leaf guards and overflows

Leaf guards must be fitted to prevent the nozzle to the downpipe from becoming blocked wherever leaves or other debris are likely to collect in the gutter. If the eaves gutter has a fascia front higher than the rear lip, an overflow must be fitted at a level below that of the lowest point in the rear lip.

3.4 Proportion

The net cross-sectional area of each vertical downpipe, including the nozzle, must be not less than 50% of the gutter discharge area.

The proportions of a rectangular eaves gutter are ideal when its width is twice the maximum depth of water flowing in it. Although a narrow deep gutter will provide a greater head of water over the outlet with a consequent improvement in the discharge capacity of the outlet, a shallower gutter is usually easier to maintain.

4. Internal Box Gutters

The procedure for the design of box gutters is as follows:

Ideally, box gutters must be straight, at least 300 mm wide, capable of supporting a workman, fixed at a slope of not less than 1 in 200, and provided with an overflow and adequate downpipe outlets not more than 18 m apart. The gutters must have sufficient slope to clear dust and debris and they might need leaf guards.

4.1 Size of gutter

Space the downpipes suitably and calculate the catchment area per downpipe. From Figure 4.1.1 using the calculated catchment area and 100 mm/hr rain intensity, determine the design flow for the gutter and the downpipe. Select a width of not less than 300 mm for the box gutter.

Figure 4.1.1: Internal Box Gutter Design Flow

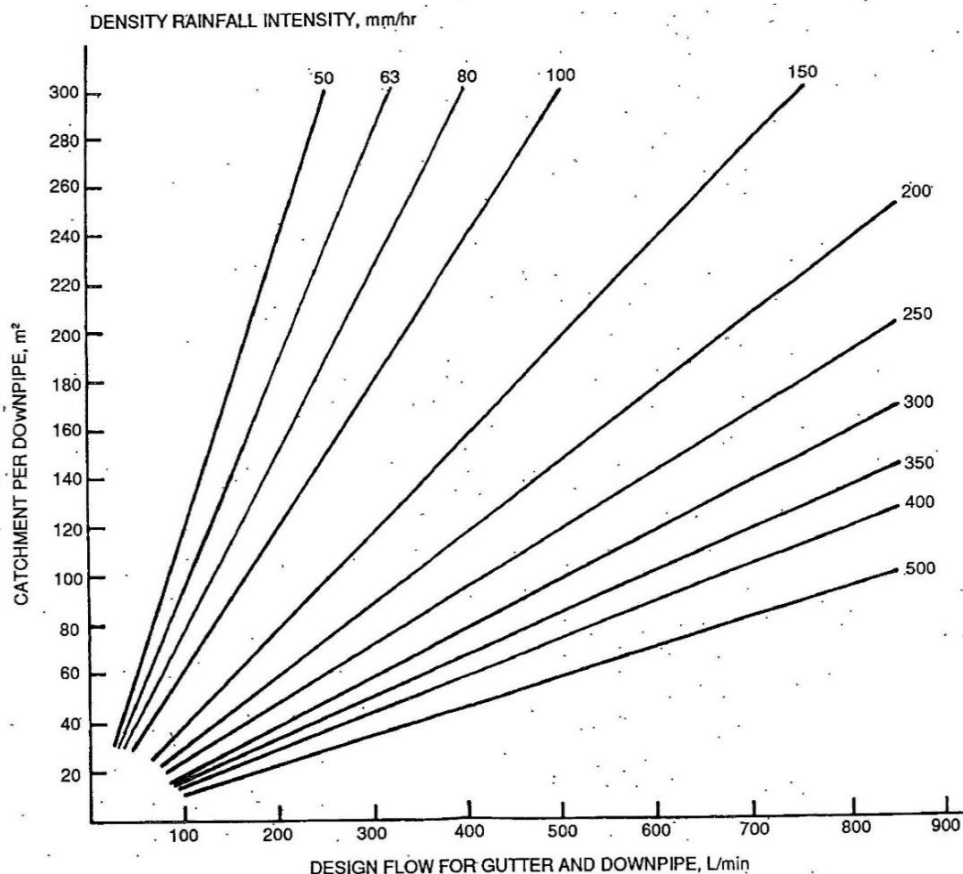

SECTION NF – HEALTH AND AMENITY

The required depth can then be read from Figure 4.1.2 by using the selected width and the design flow. The depth allows for a freeboard of 35 mm, which will be necessary during cyclonic winds along with normal turbulence and ripples. The depth thus determined assumes that the gutter is laid to zero slope. To adjust for the slope, use the depth determined from Figure 4.1.2 in Figure 4.1.3 and read off the depth adjusted for slope against the appropriate slope line. The minimum depth must be 80 mm.

Figure 4.1.2: Required Depth of Box Gutter for Design Flow

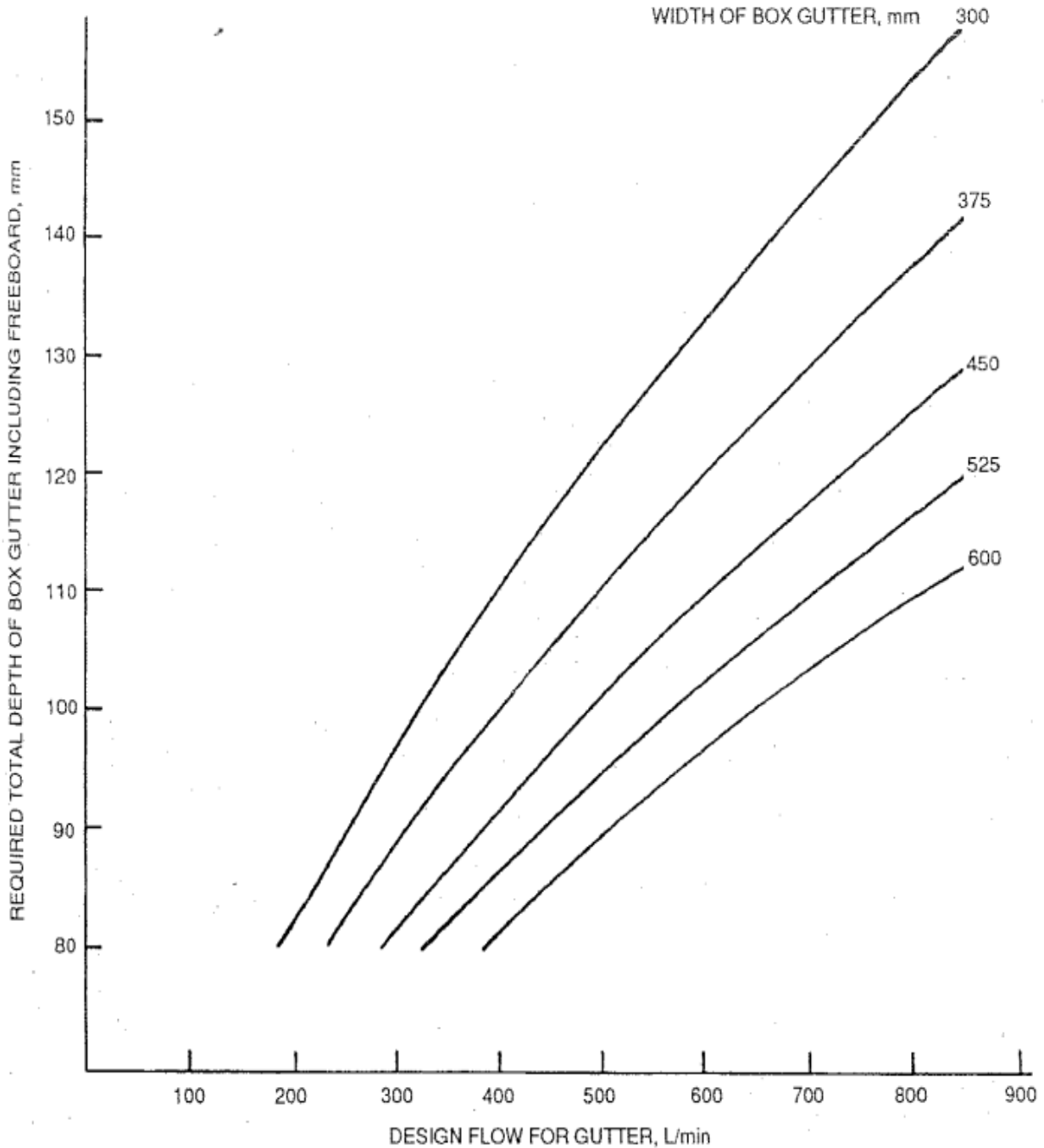

Notes:

- 1 Graph assumes zero slope. To take advantage of slope, see Fig. 4.1.3.
- 2 Graph assumes 35 mm freeboard.

Figure 4.1.3: Box Gutter Depth: Adjusted for Slope

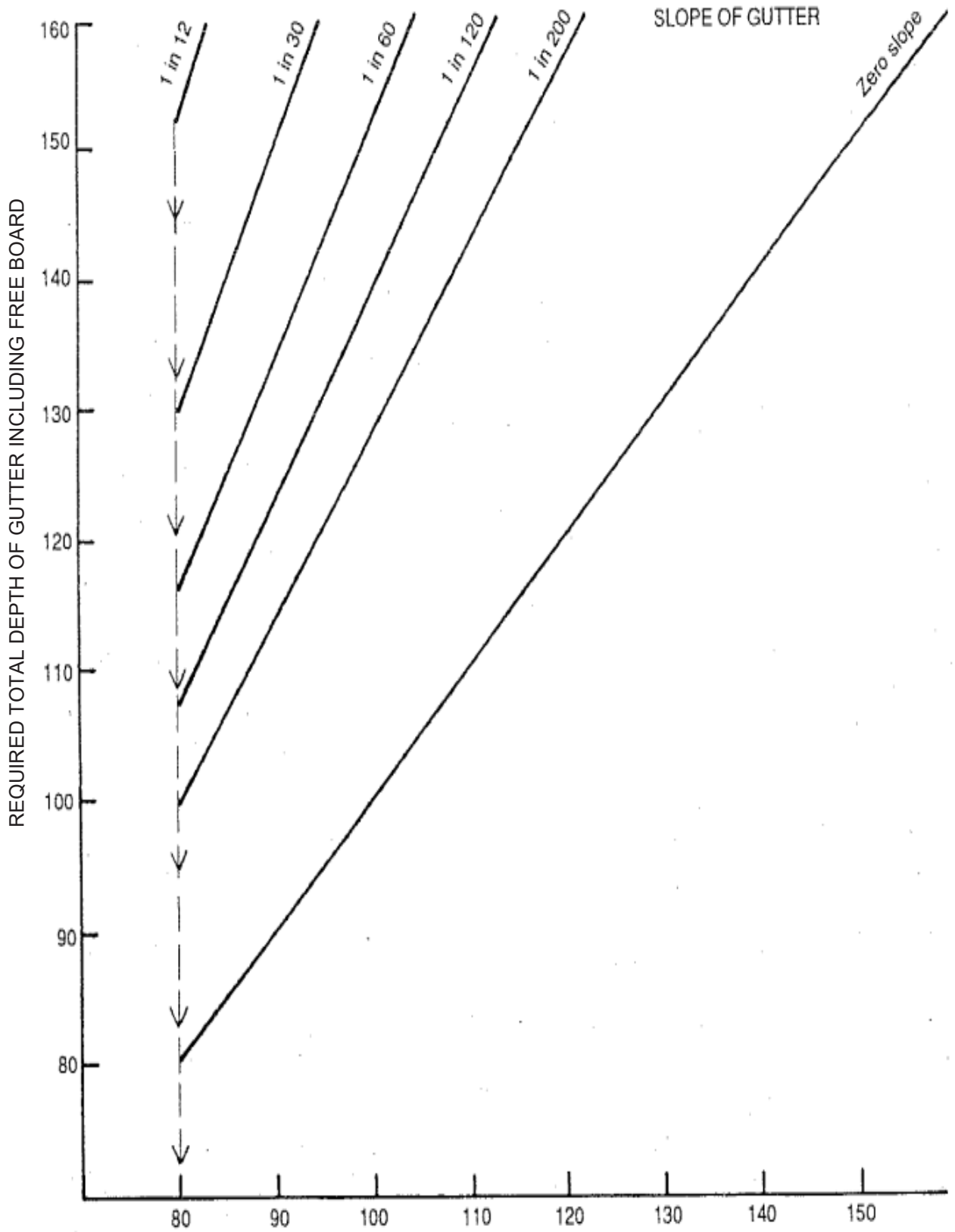

4.2 Size of downpipe

The size of the downpipe can be determined from Figure 4.2 by reading against the design flow and the actual depth of the gutter determined from using Figure 4.1.3. The downpipes can be round or rectangular.

Figure 4.2: Required Size of Downpipe for Box Gutter (Rain Head and Sump Not Considered)

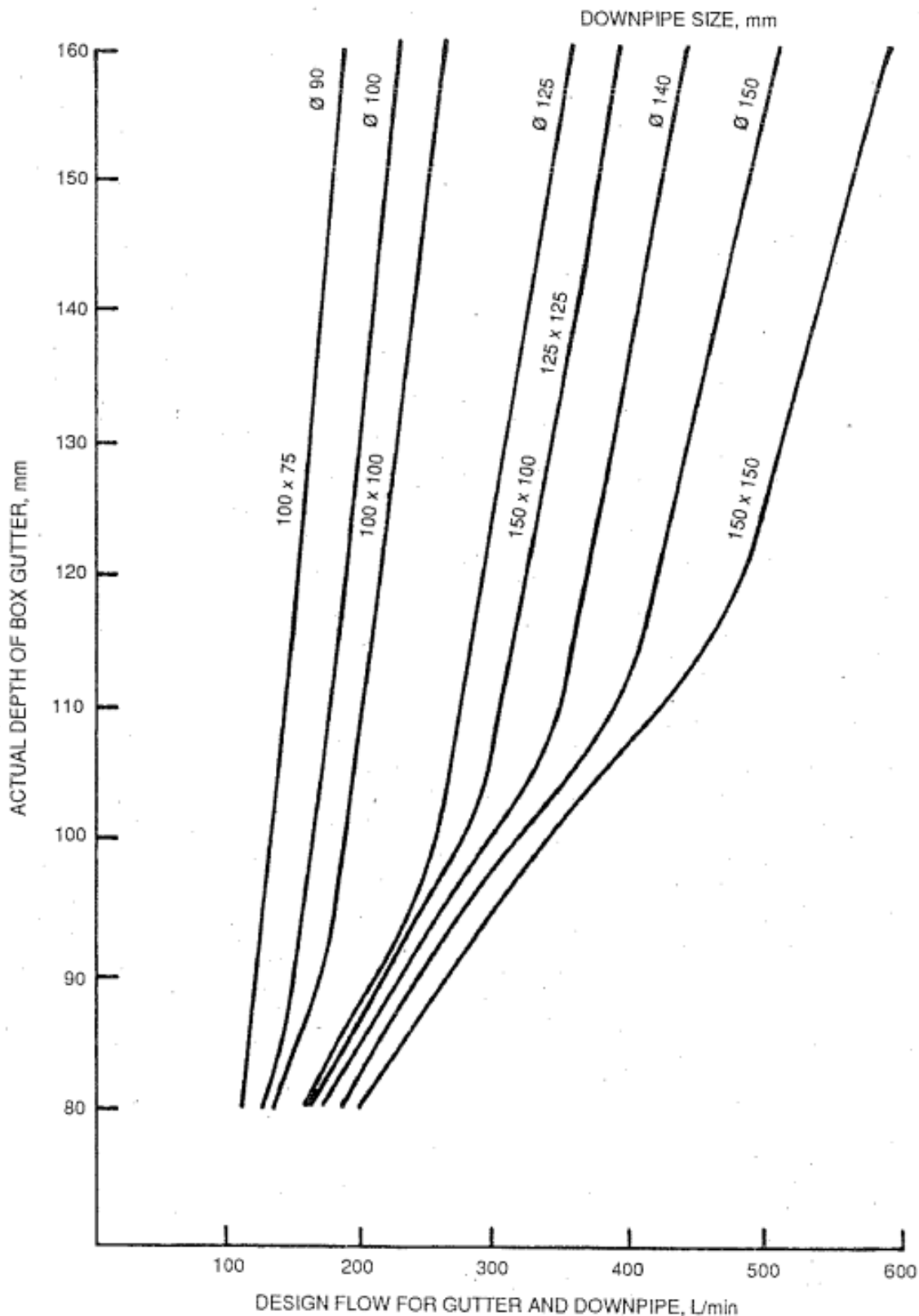

4.3 Overflow

A box gutter discharging directly into a downpipe must have an overflow outlet to allow for blockage and to provide for rainfall intensities greater than those used for design. To cope only with peaks in rainfall, it is sufficient for the overflow outlet to have a cross-sectional area equal to 15% of the total cross-sectional area of the gutter that is an overflow area of $0.15 \text{ depth} \times \text{width}$ (see Figure 4.3.1).

Figure 4.3.1: Overflow Outlet

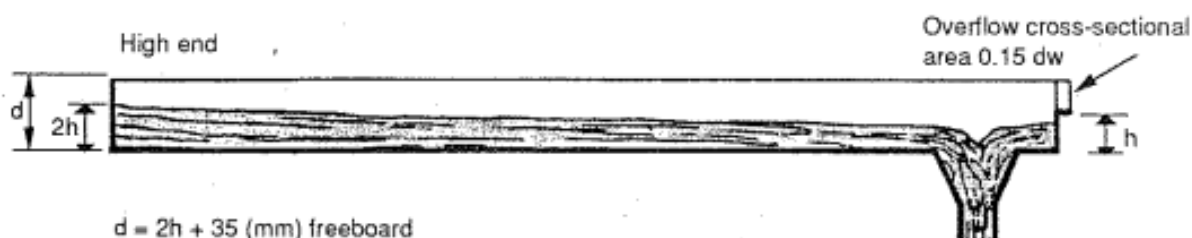

But if the overflow is intended to cope with the effect of a total blockage of the downpipe during a peak period, then the cross-sectional area of the overflow outlet must equal the cross-sectional area of the water flow at the outlet of the gutter ($h \times w$ for minimum fall). The overflow should be slightly above level h and if it is the same width as the gutter, the depth of the gutter will have to be further increased by an amount equal to h in order to accommodate the flow of water in a crisis (see Figure 4.3.2). The slope factor must not be taken into account when determining the new depth for the gutter and the amount of freeboard added to the increased gutter depth will depend on the risk the designer wishes to take regarding the possibilities of failure of the roof-drainage system during a peak period. Other methods of preventing overflow due to blocked downpipes are the provision of rain heads and sumps.

Figure 4.3.2: Overflow with Blocked Downpipe

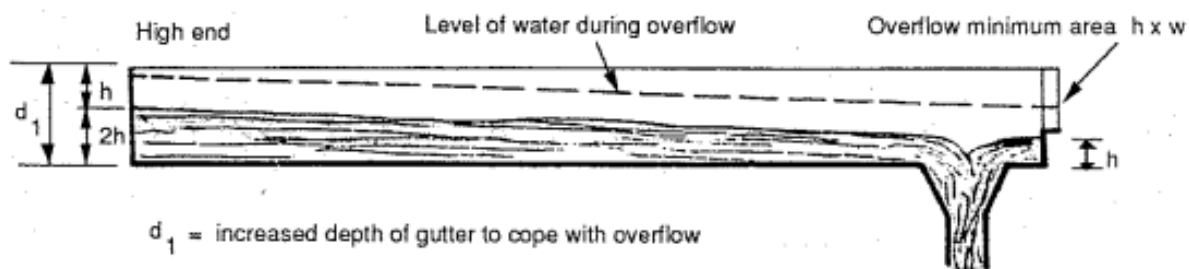

4.4 Rain heads

The rain head is a device used to increase the capacity of a downpipe at the end of a box gutter and to allow for overflow in case of a blocked downpipe. The discharge capacity of an outlet increases with the depth of water (head) over the outlet. The rain head is located at the far end of a box gutter and consists of a sump and overflow arrangements. The sump increases the flow through the downpipe by providing an additional head of water. The overflow provides safety against water spilling into the *building* if the downpipe is blocked. The detailed design of rain heads is given in AS/NZS 3500.3.

4.5 Sumps

Where a sump is fitted to the sole of a gutter it provides a local reservoir and the additional head increases the flow through the downpipe. The detailed design of sumps is given in AS 3500.3.

5. Downpipes

5.1 Location

Downpipes must be located externally, but where it is necessary to locate a downpipe internally the pipe must be accessible so that any blockage can be cleared. Access for cleaning must be provided at the base of all downpipes that are connected directly to a storm water *drain*. Downpipes are most efficient when located at the center of a length of gutter.

5.2 Swirl

The performance of an outlet with the head of water more than 113 of its diameter will be reduced if swirl occurs at the outlet. This would generally happen only where rain heads or sumps are included in the system. Swirl can be eliminated if the centerline of the downpipe is kept no more than a distance equal to its diameter or the average of its cross-sectional dimensions, away from the nearest vertical side of the rain head or the sump.

5.3 Gratings

Where a grating or strainer is fitted to a rain-water outlet the total area of the perforations in the grating must be at least 1.5 times the cross-sectional area of the outlet. Strainer gratings must project above the calculated level of flow at the outlet and must be cleared of accumulated debris regularly.

6. Incompatible Materials

Dissimilar metals must be separated by a non-conducting gasket or similar device to prevent electro-chemical corrosion. Water draining from copper components must not discharge onto non-copper components for the same reason. However, water can be safely drained from non-copper onto copper components. (The prevention of electro-chemical corrosion between metals will not necessarily prevent atmospheric corrosion of the individual metals).

7. Expansion Joints for Gutters

Metal gutters must be provided with expansion joints to prevent distortion and resulting damage and reduced flow. The maximum length between expansion joints is given in Table 8.

Table 8: Maximum Distance between Gutter Expansion Joints

Material	Estimated exposed temperature range (°C)	Distance between 20 mm expansion joints (m)
Aluminum	45	18
Copper	55	21
Stainless Steel	40	30
Steel	50	33
Zinc	50	15

9. Stormwater

9.1 Downpipe discharges into a storm water gully

Where a downpipe discharges into a storm water gully, it must terminate below the gully grating, and where the connection is made directly to a stormwater pipe underground, the internal diameter of the underground pipe must be greater than that of the downpipe. Underground stormwater pipes draining roof and paved catchments must be laid in straight lines at uniform gradients between sumps or collection pits. Large paved areas and roadways must slope towards drainage points with a minimum cross-fall of 1 in 60 for bitumen or concrete surfaces and 1 in 120 for concrete kerb channels.

9.2 Pipe sizes

Table 9.2 indicates the maximum total catchment area of roof and paving that can be drained by underground pipes laid at different gradients, of various diameters and running half full. Areas shown above the heavy line will have a flow velocity insufficient to flush out debris.

The Table is for a rainfall intensity of 115 mm/h. For other rainfall intensities, the horizontal area to be drained must be proportionally adjusted by multiplying the area by 115 and dividing by the *required* rainfall intensity. The proportionally adjusted area can be used in the Table to determine the pipe size.

Table 9.2: Stormwater Drain Sizes to Take Flow from Downpipes and Pavements

Diameter of Pipe (mm)	Maximum horizontal projected areas (m ²) that can be drained at various gradients when the rainfall intensity is 115 mm/h			
	1 in 50	1 in 100	1 in 150	1 in 200
100	220	150	130	110
150	6,000	430	350	260
200	1,300	950	780	650
250	2,350	1,650	1,300	1,130
300	3,700	2,600	2,170	1,910
375	6,700	4,700	3,820	3,130
450	8,800	6,950	5,650	4,600

Section

NG



ANCILLARY PROVISIONS

**THIS SECTION APPLIES TO PUBLIC
BUILDINGS AND GROUP DWELLINGS
(CLASS 2 to CLASS 9)**

SECTION NG – ANCILLARY PROVISIONS

Contents

PERFORMANCE REQUIREMENTS	1
OBJECTIVES & REQUIRED PERFORMANCE	1
NGP1 Minor structures and components	1
NGP1.1 Swimming Pools	1
NGP1.2 Refrigerated Chambers, Strong Rooms and Vaults	1
NGP1.3 Safety at Elevated Places	1
NGP1.4 Use of the Air Space Over Public Places	1
NGP1.5 Aesthetics	1
NGP2 Fireplaces, Chimneys and Flues	1
NGP3 Atrium Construction	1
DEEMED-TO-SATISFY PROVISIONS	3
NG1 Minor Structures and Components	3
NG1.1 Swimming Pools	3
NG1.2 Refrigerated Chambers, Strong Rooms and Vaults	3
NG1.3 Parapets on Flat Roofs	3
NG1.4 Projections over Public Places.....	3
NG1.5 Moveable Awnings or sunshades over public places	3
NG1.6 Fences	4
NG2 Fireplaces, Chimneys and Flues	4
NG2.1 General Requirements	4
NG2.2 Open Fireplaces	4
NG2.3 Incinerator Rooms	5
NG3 Atrium Construction	5
NG3.1 Design	5

PERFORMANCE REQUIREMENTS

OBJECTIVES

This Section contains more specific requirements for particular parts of *buildings* or structures.

Parts of *buildings* and structures must be so designed and constructed that the following objectives, in addition to those listed for Sections B, NC, ND, NE and NF where relevant, are fulfilled.

REQUIRED PERFORMANCE

NGP1 Minor Structures and Components

NGP1.1 Swimming Pools

- (a) Suitable means for the disposal of waste and drainage must be provided to a *swimming pool*.
- (b) Access by unsupervised young children to *swimming pools* must be restricted.

NGP1.2 Refrigerated Chambers, Strong Rooms and Vaults

Refrigerated or cooling chambers, strong rooms and vaults, or the like, which are capable of entry by a person must have adequate safety measures to facilitate escape and for alerting persons outside the chamber or vault in the event of an emergency.

NGP1.3 Safety at Elevated Places

Elevated places with regular access such as some flat roofs must have adequate protection to prevent anyone from falling.

NGP1.4 Use of the Air Space Over Public Places

Any use of the air space over public places such as footpaths and roads must be limited to ensure that normal public use of such places is not obstructed.

NGP1.5 Aesthetics

Any minor structure such as fencing, awnings and such like must be suited to the general surroundings and the occupancy of the *buildings* and the neighbourhood.

NGP2 Fireplaces, Chimneys, and Flues

Fireplaces, chimneys and flues must be adequately constructed or separated to prevent:

- (a) ignition of nearby parts of the *building*; or
- (b) escape or discharge of smoke to the inside of the *building* or to adjacent *windows*, ventilation inlets, or the like.

NGP3 Atrium Construction

The construction of an *atrium* must not unduly increase the danger to occupants from fire or smoke.

DEEMED-TO-SATISFY PROVISIONS

NG1 Minor Structures and Components

NG1.1 Swimming Pools

- (a) Drainage: A *swimming pool* must have suitable means of drainage.
- (b) Safety fencing: A *swimming pool* with a depth of water more than 300 mm must have suitable barriers or safety fencing in accordance with AS 1926.1 and AS 1926.2 to restrict access by young children to the immediate pool surrounds if the *swimming pool* is associated with a Class 2 or 3 *building* or is a public pool.
- (c) Water recirculation systems: A *swimming pool* must have suitable means of water reticulation in accordance with AS 1926.3.

NG1.2 Refrigerated Chambers, Strong Rooms, and Vaults

- (a) A refrigerated or cooling chamber which is of sufficient size for a person to enter must:
 - 1. have a door which is in an opening with a clear width of not less than 600 mm and a clear height of not less than 1.5 m; and
 - 2. at all times, be able to be opened from inside without a key.
- (b) A strong room or a vault in a *building* must have:
 - 1. internal lighting controllable only from within the room; and
 - 2. a pilot light located outside the room but controllable only by the switch for the internal lighting.
- (c) A refrigerated or cooling chamber, strong room or vault must have a suitable alarm device located outside but controllable only from within the chamber, room, or vault.

NG1.3 Parapets on Flat Roofs

Where a flat roof or other elevated place has regular access, a parapet or balustrade of not less than 1 m height above the surface of the roof or elevated place must be provided. The width of any opening in the parapet or balustrade must not exceed 100 mm.

NG1.4 Projections over Public Places

Buildings must not project beyond the allotment boundary. Architectural features such as eaves cornices clocks lamps ventilating equipment trade signs hoardings flag poles bay or oriel *windows* and such like as well as a platform or balcony to provide additional means of egress from an existing *building*, may however project over public footpaths or roads with the following minimum clearances:

- (a) 3,300 mm above existing or intended finished level of footpaths; and
- (b) the outer extremity of the feature must be set back 300 mm from the existing or intended kerb.

Any drainage from such architectural features (including drainage from air-conditioning and other ventilating equipment) must be suitably taken down to a *drain* with downpipes which must also satisfy the *required* clearances.

NG1.5 Moveable Awnings or sunshades over public places

Any moveable awnings or sunshades must be firmly fixed so that they do not create any danger obstruction or inconvenience to pedestrians. They must provide the following minimum clearances if they project over public places:

- 1. 2,300 mm above the finished levels of the footpath; and
- 2. their outer extremity must be set back 300 mm from the kerb.

NG1.6 Fences

Any fencing or free-standing wall must be suited to the occupancy of the *building* within. It must not detract from the general aesthetic appearance of the surroundings. If any barbed wire or other such is used it must be at a height of not less than 2 m above the finished level of any existing or intended adjacent footpath.

NG2 Fireplaces, Chimneys, and Flues

NG2.1 General Requirements

A chimney or flue must be constructed:

- (a) to withstand the temperatures likely to be generated by the appliance to which it is connected
- (b) so that the temperature of the exposed faces will not exceed a level that would cause damage to nearby parts of the *building*
- (c) so that hot products of combustion will not:
 - 1. escape through the walls of the chimney or flue; or
 - 2. discharge in a position that will cause fire to spread to nearby *combustible* materials or allow smoke to penetrate through nearby *windows*, ventilation inlets, or the like;
- (d) in such a manner as to prevent rainwater penetrating to any part of the interior of the *building*;
- (e) such that its termination is not less than:
 - 1. 600 mm above any point of penetration of or contact with the roof; and
 - 2. 900 mm above any opening or openable part in any *building*, within 3 m horizontal distance of the chimney or flue; and
- (f) so that it is accessible for cleaning.

NG2.2 Open Fireplaces

An open fireplace, or solid-fuel burning appliance in which the fuel-burning compartment is not enclosed, satisfies NG2.1 if it has:

- (a) a hearth constructed of stone, concrete, masonry or similar *non-combustible* material so that:
 - 1. it extends not less than 300 mm beyond the front of the fireplace opening and not less than 150 mm beyond each side of that opening;
 - 2. it extends beyond the limits of the fireplace or appliance not less than 300 mm if the fireplace or appliance is free-standing from any wall of the room;
 - 3. its upper surface does not slope away from the grate or appliance; and
 - 4. *combustible* material situated below the hearth (but not below that part *required* to extend beyond the fireplace opening or the limits of the fireplace) is not less than 155 mm from the upper surface of the hearth;
- (b) walls forming the sides and back of the fireplace up to not less than 300 mm above the underside of the arch or lintel which:
 - 1. are constructed in 2 separate leaves of solid masonry not less than 180 mm thick, excluding any cavity; and
 - 2. do not consist of concrete block masonry in the construction of the inner leaf;
- (c) walls of the chimney above the level referred to in (b):
 - 1. constructed of masonry units with a net volume, excluding cored and similar holes, not less than 75% of their gross volume, measured on the overall rectangular shape of the units, and with an actual thickness of not less than 90 mm; and
 - 2. lined internally to a thickness of not less than 12 mm with rendering consisting of 1 part cement, 3 parts lime, and 10 parts sand by volume, or other suitable material; and
- (d) suitable damp-proof courses or flashings to maintain weatherproofing.

NG2.3 Incinerator Rooms

If an incinerator is installed in a *building* any hopper giving access to a charging chute must be:

1. non-combustible;
2. gastight when closed;
3. designed to automatically return to the closed position after use;
4. not attached to a chute that connects directly to a flue unless the hopper is located in the open air; and
5. not located in a *required exit*.

If an incinerator is in a separate room, that room must be separated from other parts of the *building* by construction with a FAL of not less than 60/60/60.

NG3 Atrium Construction

NG3.1 Design

The design of an *atrium* along with the attendant life safety provisions such as fire prevention, firefighting, smoke exhaust systems, etc. must fulfil up-to-date and relevant fire engineering principles and practices.

END OF VANUATU NATIONAL BUILDING CODE